

## Application Note:

### TDPV3000E0C1 Single-Phase Inverter Evaluation Board

#### 1. Introduction

The TDPV3000E0C1 inverter kit from Transphorm provides an easy way to evaluate the performance advantages of GaN power transistors in various inverter applications, such as solar and UPS. The kit provides the main features of a single-phase inverter in a proven, functional configuration, operating at or above 50kHz. At the core of the inverter are four GaN transistors configured as a full bridge. These are tightly coupled to gate-drive circuits on a board which also includes flexible microcontroller options and convenient communication connection to a PC. The switch-mode power signals are filtered to provide a pure sinusoidal output.

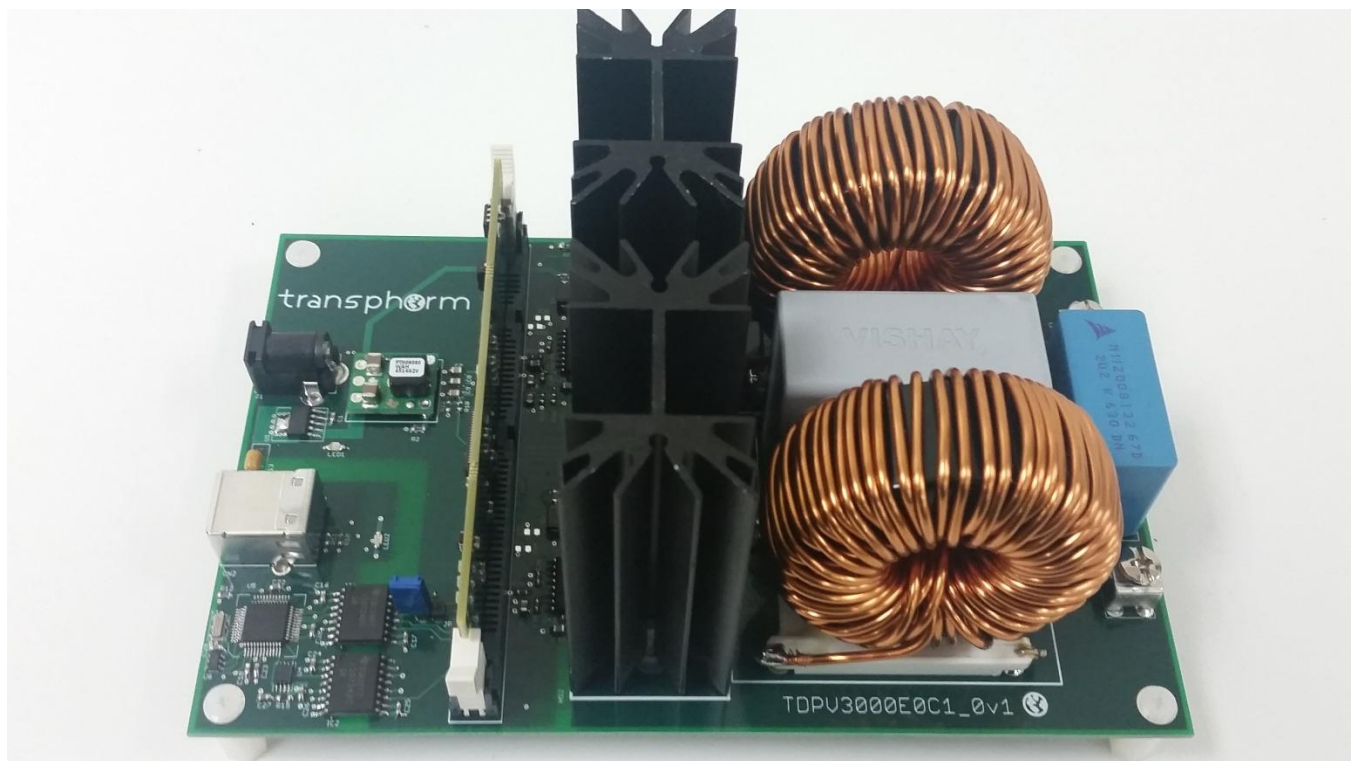

Fig. 1. Single-Phase Inverter Evaluation Board

The control portion of the circuit is designed around the popular C2000™\* family of microcontrollers from Texas Instruments. Source code is available along with related support information directly from TI. In addition to this general resource, however, Transphorm provides original firmware which comes loaded in flash on the microcontroller. The source code, configured as a complete project, is also provided on the USB memory stick which comes with the kit. This project is a convenient starting point for further developments. The microcontroller itself resides on a small, removable control card, supplied by TI, so that different C2000 devices may be used if desired. The schematic for the TDPV3000E0C1 circuit board is provided on the USB memory stick.

\*C2000™ is a trademark of Texas Instruments Incorporated.

## Kit Contents

The kit comprises

- A TDPV3000E0C1 single-phase inverter assembly
- A Texas Instruments F28035 controlCARD
- A 12V power supply with universal AC adaptors
- Related media (documentation and software) on a USB memory stick
- Cable for, high-voltage DC input

## Warning

While this kit provides the main features of an inverter, it is not intended to be a finished product. Our hope is that this will be a tool which allows you to quickly explore ideas which can be incorporated in your own inverter design. Along with this explanation go a few warnings which should be kept in mind:

To keep the design simple and to provide ready access to signals of interest, high-voltages are present on exposed nodes. It is up to you to provide adequate safeguards against accidental contact, or use by unqualified personnel, in accordance with your own lab standards.

There is no short-circuit or over-current protection provided at the output. Current-sense devices are connected to the AC outputs, and may be used for over-current protection, but it should not be assumed that the firmware, as delivered, includes such a feature.

## 2. TDPV3000E0C1 Input/output Specifications:

- Input: 0-400Vdc:
- Output:  $V_{dc} / \sqrt{2}$   $V_{rms}$  at 50/60Hz\*, up to 3000VA;
- PWM Frequency: 50kHz to 150kHz\*\*
- Auxiliary Supply ( $V_{gg}$ ): 12Vdc.

\*The output frequency may be changed in the software. As delivered it is 60Hz.

\*\*The switching frequency may be changed in the software. As delivered it is 50kHz.

## 3. Circuit Description

### Overview

Refer to Figure 2 for a block diagram of the inverter circuit. A detailed schematic is also provided in pdf format on the USB stick which comes with the kit.

The TDPV3000E0C1 inverter is a simple full-bridge inverter. Two GaN half bridges are driven with pulse-width modulated command signals to create the sinusoidally varying output. The output filter largely removes the switching frequency, leaving the 50/60Hz fundamental sinusoid. The high-frequency (50kHz+) PWM signals are generated by the TI microcontroller and connected directly to high-speed, high-voltage gate drivers. A connection for external communication to the microcontroller is provided by an isolated USB interface. Except for the high-voltage supply for the power stage, all required voltages for the control circuitry are derived from one 12V input.

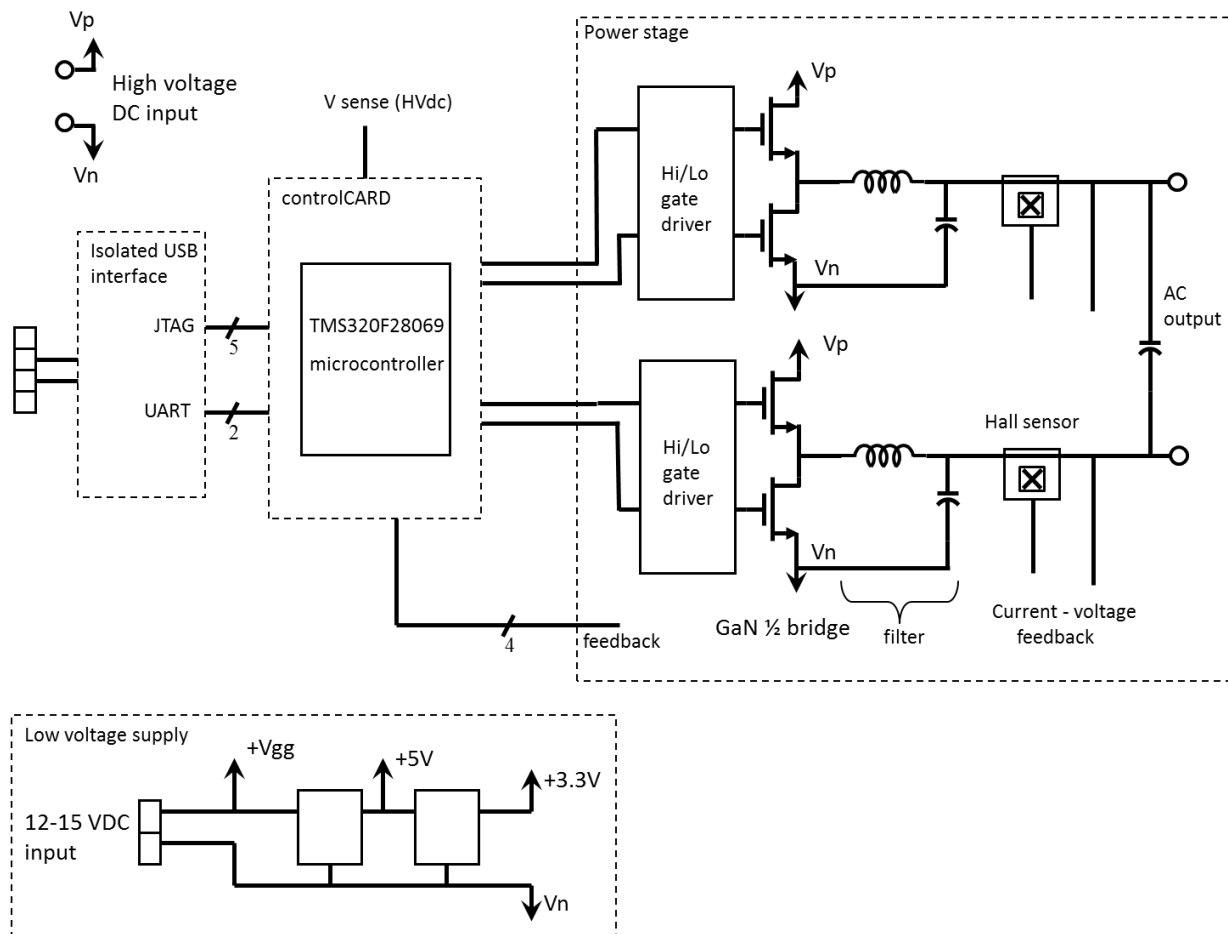

Fig .2. Circuit block diagram

The inverter takes advantage of diode-free operation\*, in which the freewheeling current is carried by the GaN HEMTs themselves, without the need of additional freewheeling diodes.

\*US patent 7,965,126 B2

For minimum conduction loss, the gates of the transistors are enhanced while they carry the freewheeling current. The high and low-side  $V_{gs}$  waveforms are therefore pairs of non-overlapping pulses, as illustrated in Figure 3.

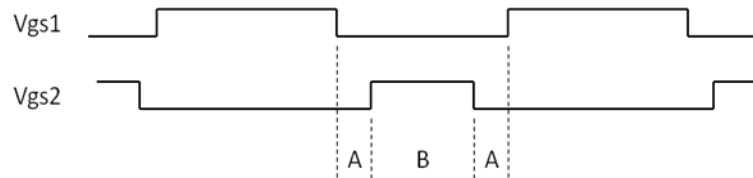

Figure 3: non-overlapping gate-drive pulse. A is a deadtime set in the firmware

## Gate Drivers

High-voltage integrated drivers supply the gate-drive signals for the high and low-side power transistors. These are 600V high-and-low-side drivers (Silicon Labs Si8230 family), specifically chosen for high-speed operation without automatic deadtime insertion. The deadtime between turn-off of one transistor in a half bridge and turn-on of its mate is set in the firmware.

## Output Filter

A simple LCL filter on the output (L3, L4, C37, and C54-57) attenuates the switching frequency, producing a clean sinusoidal waveform for output connections at terminals J4 and J5. The filter inductors and capacitors used on the demo board were chosen to provide an optimal combination of benefits: low loss, good attenuation of the switching frequency, and small size. Consult the schematic and/or bill of materials to verify values, but in general the cutoff frequency will be around 5-10kHz, to accommodate 50kHz switching. The inductors have powder cores with relatively low permeability (60-90) and soft saturation characteristics. The inductors and/or capacitors can be changed to evaluate different filter designs.

## Current sensing

Hall sensors U8 and U10 provide linear current feedback to the microcontroller. These signals could be used to control output power flow, and/or to protect against short circuits. The firmware provided with the kit, however, does not actually make use of this feedback. Note that these are placed at an intermediate point of the output filter. Refer to the bill of materials to confirm the sensor part numbers, but typical would be the Allegro ACS712-20A sensor, which

has a  $\pm 20A$  range (100mV/A). These parts are pin compatible with  $\pm 5A$  and  $\pm 30A$  versions of the ACS712, should higher or lower ranges be desired. Note also that resistor dividers scale the 5V outputs for the 3V range of the A/D.

## Communication

Communication between the microcontroller and a computer is accomplished with a standard USB cable. The isolated USB interface enables simultaneous operation of two physical ports to the microcontroller: a JTAG port for debug and loading of firmware, and a UART for communication with a host application.

## Control Card

The microcontroller resides on a removable card, which inserts in a DIM100 socket on the inverter PCB. The socket can accept many of the C2000<sup>TM</sup> series controlCARDS from Texas Instruments. The TMDSCNCD28035 Piccolo controlCARD supplied with the kit provides capability to experiment with a wide variety of modulation and control algorithms. It comes loaded with firmware to allow immediate (out-of-the-box) operation. Should the user wish to use an alternate microcontroller family, an appropriate control card can be designed to insert into the DIM100 socket.

## Heat Sink

The two TO-247 GaN transistors of each half bridge are mounted to a common heat sink. The heat sink is adequate for 2000W operation with forced air flow. Even higher efficiency at high power may be achieved by minimizing the temperature rise. This may be accomplished with forced airflow. Alternately the heat sinks could be replaced with larger or more effective ones.

## Connections

Power for the AC output is derived from the HV DC input. This will typically be a DC power supply with output voltage up to 400Vdc. A 22uF, low ESR, film capacitor is provided as a bypass capacitor for the HV supply, along with several lower valued ceramic capacitors in parallel. This is not intended to provide significant energy storage. It is assumed that the power supply or preceding DC-DC stage contains adequate output capacitance.

The control, communication, and gate-drive circuits are all powered from a single 12V input (V<sub>gg</sub>). The wall-plug adaptor provided generates the appropriate voltage (typically 12V) and power level.

Note that only the USB port is isolated; all other signals on the board are referenced to the negative terminals of the high and low voltage supplies, which are tied together on the PCB. The heat sinks are also connected to the negative terminal of the supplies.

## **Connection sequence**

Refer to figure 5. Insert the microcontroller card in the DIM100 connector before applying any power to the board. To use the preloaded firmware, verify that jumper JP1 is removed. This releases the JTAG port and allows the microcontroller to boot from flash. For communication with a host over the JTAG port, JP1 should be installed.

With the supply turned off, connect the high-voltage power supply to the +/- inputs (J2 and J3). If a load is to be used, connect it to the output terminals (J4 and J5).

Insert the V<sub>gg</sub> (12V) plug into jack J1. LED1 should illuminate, indicating power is applied to the 5V and 3.3V regulators. Depending on the specific control card used, one or more LEDs on the control card will also illuminate, indicating power is applied. A flashing LED indicates the firmware is executing.

To use the pre-loaded firmware no computer connection is required. If a computer connection is required for code modification, connect the USB cable from the computer to the USB connector (CN3). LED2 should illuminate, indicating isolated +5V power is applied over the USB cable.

Turn on the high voltage power. The high-voltage supply may be switched on instantly or raised gradually.

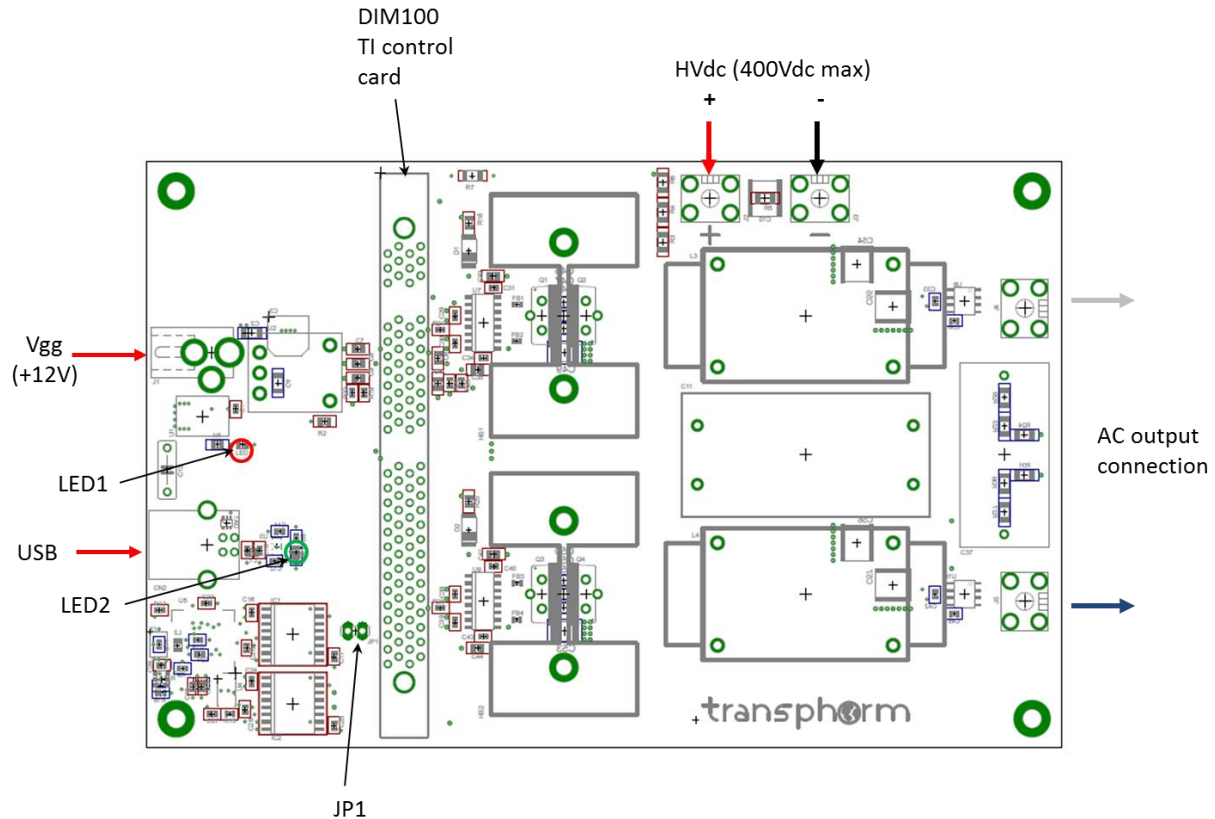

Figure 5: Connections

## Test

Figure 6 shows typical waveforms. The negative terminal of the high-voltage supply is a convenient reference for oscilloscope measurements, provided there are not multiple connections to earth ground.

Typical efficiency results are shown in Figure 7. These data points correspond to efficiency measurements made in still air with 30 seconds dwell at each power level. Input power from the 350Vdc source and output power to a resistive load were measured with a Yokogawa WT1800 power analyzer.



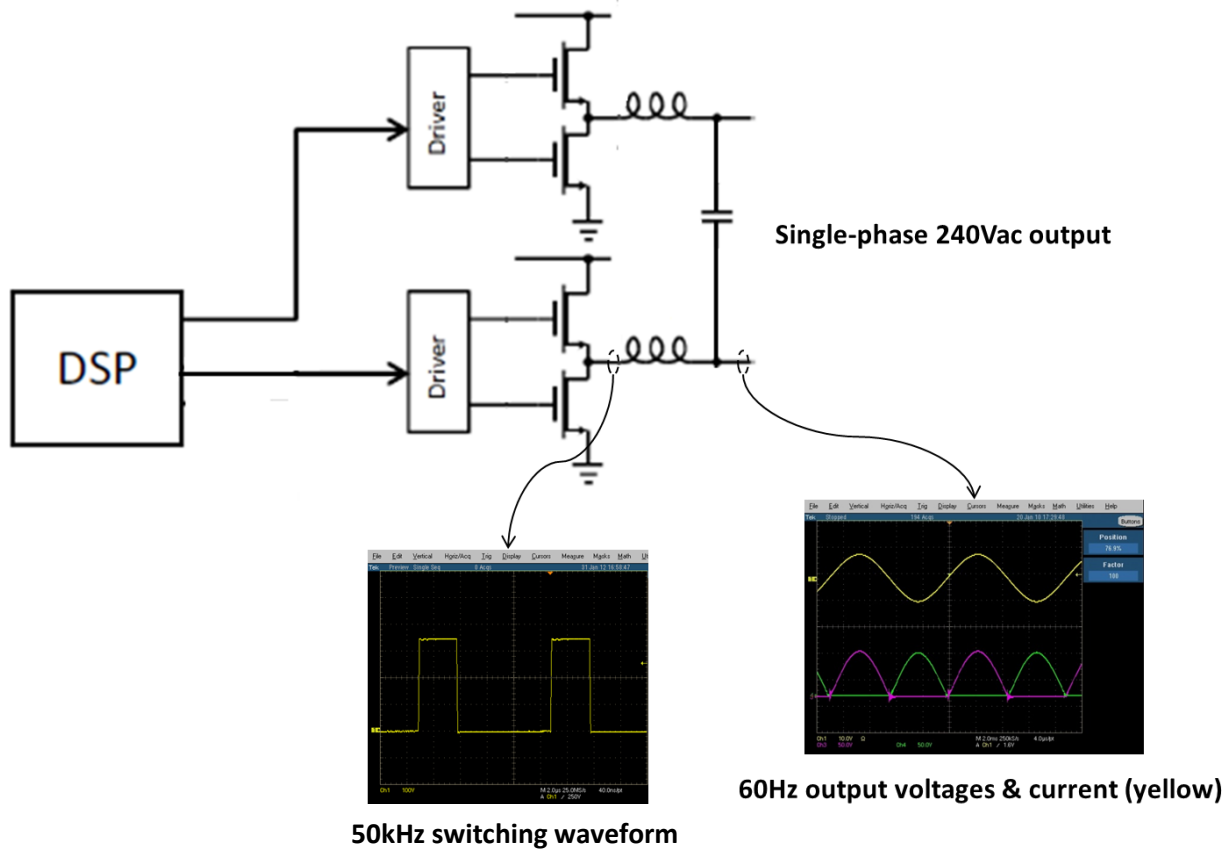

Figure 6. Typical Waveforms

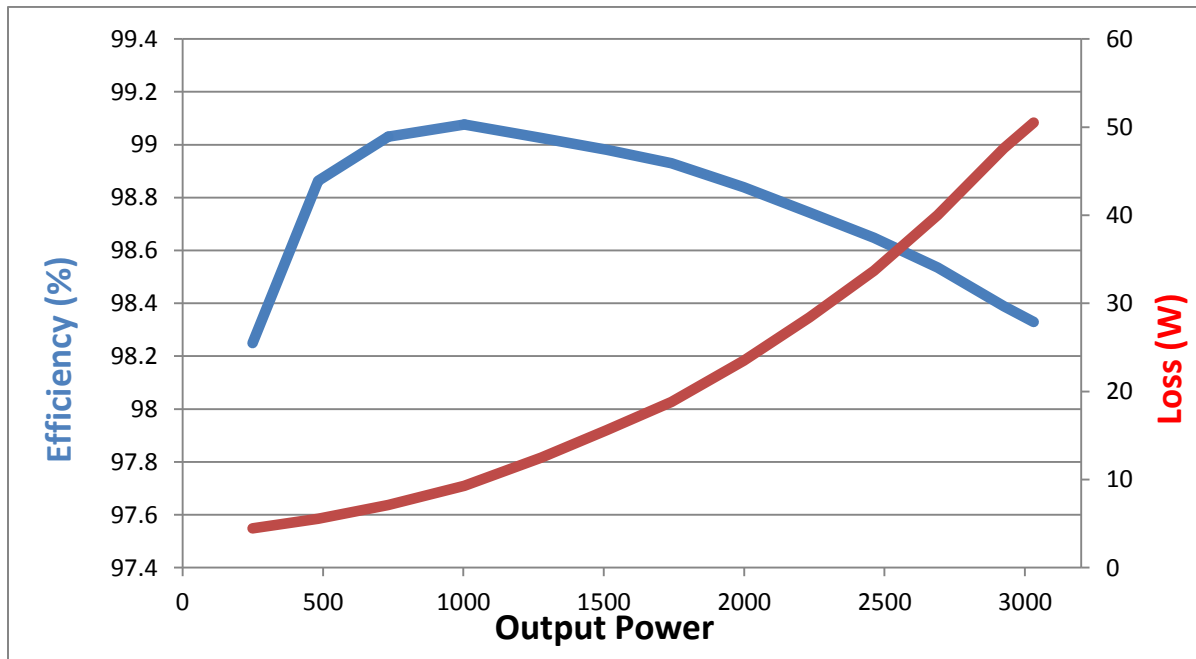

Figure 7. Typical Efficiency 350Vdc input, 240Vac output

## Bill of Materials

Qty	Value	Manufacturer	Parts	Manf P/N
2	HEATSINK TO-220 POWER W/PINS BK	529802B02500G	HS1, HS2	530002B02500G
1	CER RESONATOR	CSTCR	X1	CSTCR6M00G53Z-R0
2	DIODE FAST REC	DO-214AC	D1, D2	ES1J
4	TERM SCREW	KEYSTONE_7691	J2, J3, J4, J5	7691
2	LED 630NM RED	CHIP-LED0805	LED1, LED2	SML-211UTT86
1	CONN HEADER VERT SGL 2POS GOLD	1X02	JP1	961102-6404-AR
1	CONN PWR JACK 2.1X5.5MM HIGH CUR	PJ-002AH	J1	PJ-002AH
1	CONN RECEPT USB TYPE B PCB	USBSHIELD	CN2	897-43-004-90-000000
2	.1u	C1812	C49, C53	C1812V104KDRACTU
24	.1u	C0603	C1, C14, C16, C17, C19, C20, C21, C22, C23, C24, C25, C26, C27, C28, C29, C30, C31, C33, C34, C38, C39, C40, C42, C43	06033C104JAT2A
5	.1u	C0805	C5, C6, C7, C8, C9	08053C104KAT2A
5	.1u	C2225K	C10, C54, C55, C56, C57	VJ2225Y104KXGAT
4	0	R0603	RG1, RG2, RG3, RG4	MCT06030Z0000ZP500
1	0	R1206	R7	ERJ-8GEY0R00V
1	1M	R0603	R14	MCR03EZPFX1004
2	1k	R0603	R8, R15	MCR03EZPJ102
1	1k	R0805	R1	ERJ-6GEYJ102V
2	1n	C0603	C36, C45	06035C102KAT2A
2	1u	C0603	C12, C18	CC0603KRX5R6BB105
1	2.2u	C0603	C15	0603YD225MAT2A
2	2k2	R0603	R13, R17	ERJ-3GEYJ222V
1	2u/630V	EPCOS_B32674	C37	B32674D6225K
6	4.7n	C1206	C46, C47, C48, C50, C51, C52	C1206C472KDRACTU
2	5.23k	R0603	R19, R26	ERJ-3EKF5231V
2	5.76k	R0603	R21, R28	ERJ-3EKF5761V

8	15	R1206	RSN1, RSN2, RSN3, RSN4, RSN5, RSN6, RSN7, RSN8	RNCP1206FTD15R0
3	9.09k	R1206	R6, R24, R31	ERJ-8ENF9091V
2	10.2k	R0603	R22, R29	ERJ-3EKF1022V
1	10MEG	R1206	R5	HVCB1206FKC10M0
2	10k	R0603	R12, R16	ERJ-3GEYJ103V
6	10u	C0805	C32, C35, C41, C44, C58, C59	C0805C106M4PACTU
1	10u	C1206	C4	12063D106KAT2A
2	15	R0805	R18, R25	RMCF0805FT15R0
4	47pF	C1210	CSN1, CSN2, CSN3, CSN4	VJ1210A470JXGAT5ZL
1	22u	C1206	C2	CL31X226KAHN3NE
2	22u	805	L1, L2	LQM21FN220N00L
2	27	R0603	R10, R11	CRCW060327R0FKEA
1	93LC46B	SOT23-6	U6	93LC46BT-I/OT
1	100n	C075-032X103	C13	SA111E104MAR
1	100u	PANASONICSMALCAP6X6	C3	EEE-FPE101XAP
1	348	R0805	R2	ERJ-6ENF3480V
1	470	R0603	R9	ESR03EZPF4700
6	560k	R1206	R3, R4, R20, R23, R27, R30	RC1206FR-07560KL
2	ACS712	SO8	U8, U10	ACS712ELCTR-20A-T
1	BAW567	SOT363	DA1	BAW567DW-7-F
1	DIM100_TICONTROLCARD	DIM100	CN1	876301001
1	FT2232D	LQFP48	U5	FT2232D-REEL
1	GLOBE	GLOBE	U\$1	GLOBE
1	ISO7240	SO-16DW	IC1	ISO7240CDW
1	ISO7242	SO-16DW	IC2	ISO7242CDW
1	LVC2G74	DCT	U4	SN74LVC2G74DCTR
1	MKP1848622454P4	MKP1848622454P4	C11	MKP1848622454P4
2	PFC-03100-00_JC	PFC-03100-00	L3, L4	PFC-03101-00
1	PTH08080WAH	PTH08080W_TH	U2	PTH08080WAH
2	SI8230	SOIC16N	U7, U9	SI8230BB-B-IS1
4	TPH3205WSA	TPH3205WSA	Q1, Q2, Q3, Q4	TPH3205WSA
1	TPS73033	SOT23-5	U3	TPS73033DBVR
1	TPS79533	SOT223-6	U1	TPS79533DBVR

1	PCB	TDPV3000E0C1	TDPV3000E0C1	
1	low side thermal pad (0.8W/m-k)	low side thermal pad	low side thermal pad	HF115AC-0.0055-AC-90
1	high side thermal pad (3.5W/m-k)	high side thermal pad	high side thermal pad	4169G
2	plastic shoulder washers	plastic shoulder washers	plastic shoulder washers	3049
2	jumper	CONN SHUNT 2POS .100	CONN SHUNT 2POS .100	65474-002LF
1	#4-40, 3/8" phillips pan head screw	#4-40, 3/8" phillips pan head screw	#4-40, 3/8" phillips pan head screw	9901
1	#4-40 hex nut	#4-40 hex nut	#4-40 hex nut	4694
4	standoffs 4-40 5/8"	standoffs 4-40 5/8"	standoffs 4-40 5/8"	1902F
1	CONTROL CARD PICCOLO F28035	CONTROL CARD PICCOLO F28035	CONTROL CARD PICCOLO F28035	TMDSCNCD28035
1	12V adaptor	ADPT MULTI-BLADE 12VDC 1.5A P5PS	ADPT MULTI-BLADE 12VDC 1.5A P5PS	EMSA120150-P5P-SZ