



# CW3002G

## USB Charging Controller

### Features

- D+/D- DCP Mode per USB Battery Charging Specification 1.2
- D+/D- Short Mode per Telecommunication Industry Standard YD/T1591-2009 (Chinese)
- Supports non-BC1.2 Charging Modes by Automatic Selection
  - D+/D- Option for Apple Device
  - D+/D- Option for Samsung Device
- Operating Voltage Range: 4.5V to 5.5V
- Power Consumption
  - 5 $\mu$ A When VDD<POR Threshold
  - 50 $\mu$ A When VDD>POR Threshold
- Lead(Pb)-Free, Halogen-Free, SOT23-5 Package

### Applications

- Power Bank
- USB Ports (Hosts and Hubs)
- Car Charger
- Wall Charging Adapters

### General Description

The CW3002G is the USB dedicated charging controller IC, which is fully compatible with BC1.2 and other non-BC1.2 standards like YD/T1591-2009, Apple charging specification (for i-Pad & i-Phones) and specs from Samsung Galaxy family.

The IC is used to facilitate charging procedure when most of the mainstream handheld devices are detected.

The CW3002G is suitable for all the charger products using USB interface like power bank, wall adapter and car charger. The IC is provided with enhanced ESD protection up to +/-8kV with application on D+/D- Pins.

CW3002G is available in tiny SOT23-5 package.

### Typical Application

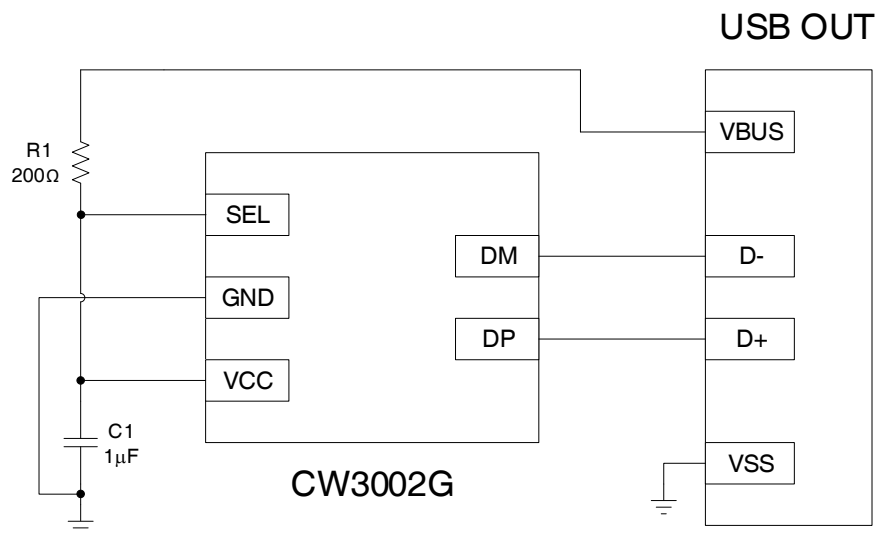

Figure 1. 2.4A Configuration / Typical Application Circuits

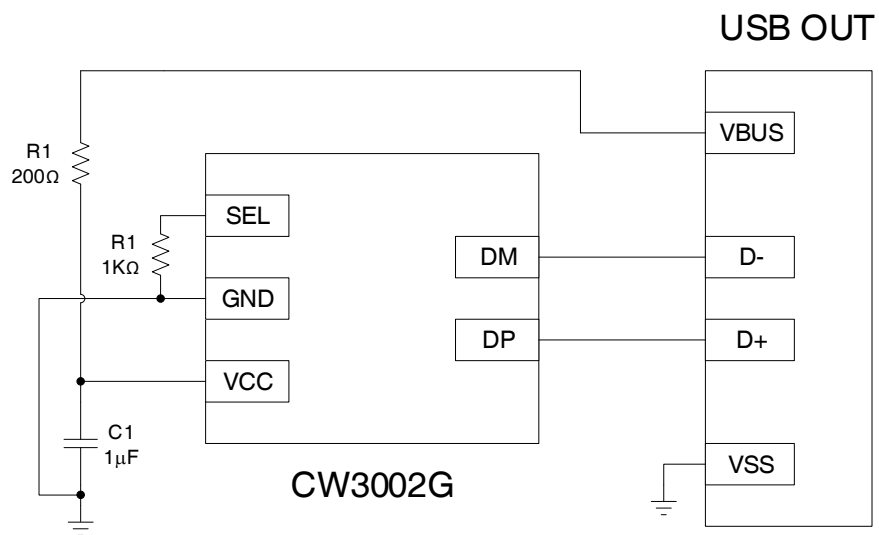
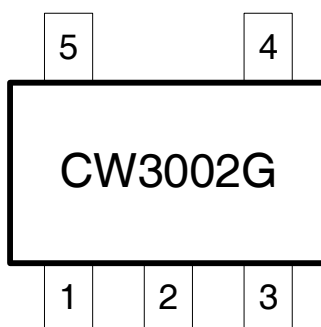

Figure 2. 1A Configuration / Typical Application Circuits

### Ordering Information

PART	OPERATING TEMPERATURE	PACKAGE	TOP MARK
CW3002GAAS	-30°C to 80°C	SOT23-5	3002G

### Pin Configuration



### Pin Descriptions

PIN	NAME	DESCRIPTION
1	SEL	Work mode selection with 1μA pull up current
2	GND	Ground
3	VCC	Power
4	DP	USB positive data-channel to external USB device
5	DM	USB negative data-channel to external USB device

### Type Number

CW3002GXXX

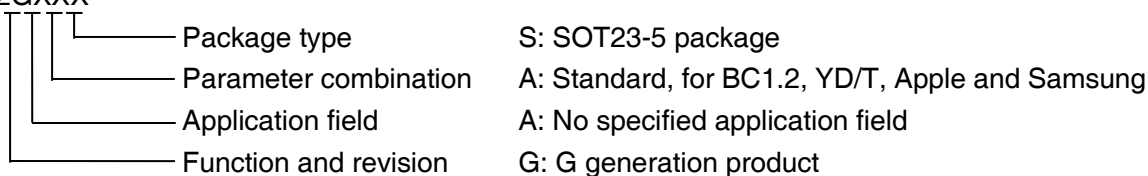

### Absolute Maximum Ratings

		VALUE		UNITS
		MIN	MAX	
Voltage on VCC Pin Relative to GND	GND	-0.3	6	V
Voltage on SEL Pin Relative to GND	GND	GND-0.3	VCC+0.3	V
Voltage on DP DM Relative to GND	GND	GND -0.3	VCC+0.3	V
Operating Temperature Range	T <sub>A</sub>	-30	80	°C
Junction Temperature	T <sub>J</sub>	-40	125	°C
Store Temperature Range	T <sub>STG</sub>	-40	150	°C
ESD	D+/D- Pins to GND. HBM model.		±8	kV

**Caution:**

Stresses beyond "Absolute Maximum Ratings" condition may cause permanent damage to the device. These are stress ratings only and functional operation of the device at these or any other beyond those indicated in the operational sections of the specifications is not implied. Exposure to absolute maximum rating conditions for extended periods may affect device reliability.

### Recommended DC Operating Conditions

4.5 ≤ VCC ≤ 5.5, T<sub>A</sub> = -30~80°C, unless otherwise specified

PARAMETER	SYMBOL	CONDITIONS	MIN.	TYP.	MAX.	UNITS
VCC Voltage			4.5		5.5	V
VCC POR Voltage	VCC <sub>POR</sub>		3.5		3.9	V
	VCC <sub>POR_HYS</sub>			250		mV

### Electrical Characteristics

4.5 ≤ VCC ≤ 5.5, T<sub>A</sub> = -30~80°C, unless otherwise specified

PARAMETER	SYMBOL	CONDITIONS	MIN.	TYP.	MAX.	UNITS
DC Current Consumption	I <sub>VCC</sub>			50		μA
Default Voltage on DP/DM pin	V <sub>OUT</sub>	Output voltage=2.7V, VCC=5V	2.6	2.7	2.8	V
		Output voltage=2.0V, VCC=5V	1.9	2	2.1	V
Output Resistance on DP/DM pin	R <sub>OUT</sub>	Output voltage=2.7V, VCC=5V		21		kΩ
		Output voltage=2.0V, VCC=5V		21		kΩ
Short Condition Resistance	R <sub>DMDP</sub>			50		Ω
SEL pull up current	I <sub>SEL_PU</sub>			1		μA

### Function Block Diagram

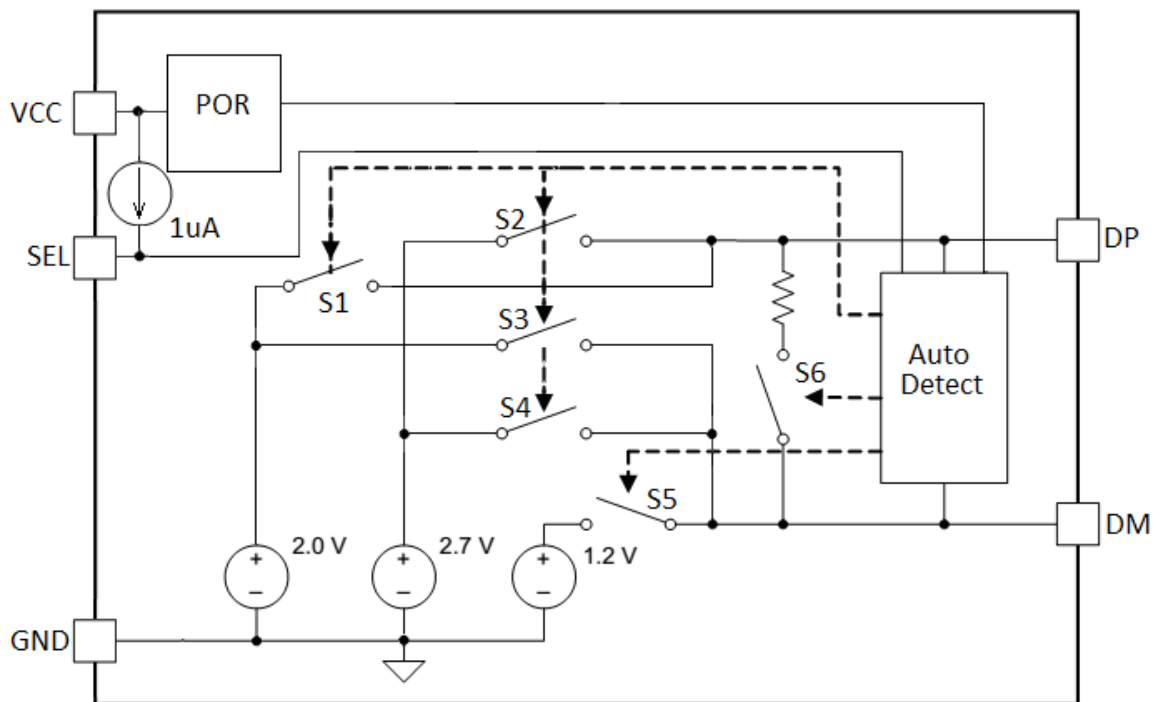

## Detailed Description

### Function

CW3002G is a specified USB charger controller IC for external device charging. CW3002G, integrated with intelligent USB detection circuits, can identify most of the handheld equipment in market, such as Apple, Samsung, HTC mobile phones and other USB supplied devices.

CW3002G monitors the D+/D- voltage all the time, and automatically emulates the corresponding USB type for the attached device. Then, the attached device can deploy a big current as MAX as 2.4A to charge itself.

CW3002G only changes the D+/D- voltage to suitable value for different devices; it does not control the charging current loop. The actual charge current is determined by the power supply and the charge management IC in attached device.

### SEL Pin

CW3002G uses a SEL pin to choose the different Apple device charge current.

Pull low through a resistor less than (or equal to)  $1k\Omega$  is for 1A option; Pull high for 2.4A option.

Table 1. SEL Pin for Different Current Option

SEL POTENTIAL	OPTION
1	2.4A
0 ( $R \leq 1k\Omega$ )	1A

### Package Information

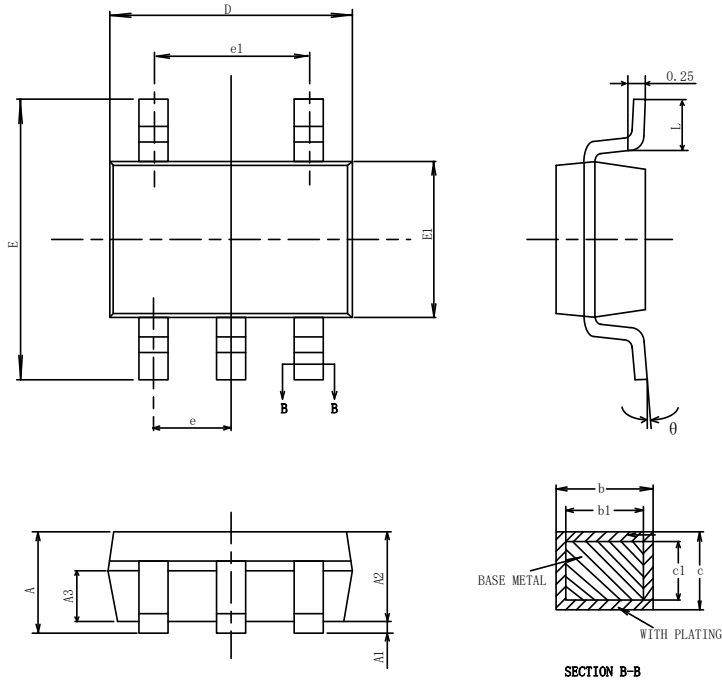

SYMBOL	MILLIMETER		
	MIN	TYP	MAX
A	—	—	1.35
A1	0.04	—	0.15
A2	1.00	1.10	1.20
A3	0.55	0.65	0.75
b	0.38	—	0.48
b1	0.37	0.40	0.43
c	0.11	—	0.21
c1	0.10	0.13	0.16
D	2.72	2.92	3.12
E	2.60	2.80	3.00
E1	1.40	1.60	1.80
e	0.95BSC		
e1	1.90BSC		
L	0.30	—	0.60
$\theta$	0	—	8°
L/F size (mil)	47*47	—	46*64

## Revision History

DATE	VERSION	CHANGED ITEM	WRITTEN BY	APPROVED BY
2018-05-02	1.0	Initial Release	Roy	Jun

---

## DISCLAIMER

*CELLWISE reserves the right to make changes without further notices to any products herein to improve reliability, function or design. CELLWISE does not assume any liability arising out of the application or use of any product or circuit described herein; neither does it convey any license under its patent rights, nor the rights of others.*

*CELLWISE's products are not authorized for use as critical components in life support devices or systems without the express written approval of the president of CELLWISE corporation.*

*As used herein:*

*1. Life support devices or systems are devices or systems which, (a) are intended for surgical implant into the body, or (b) support or sustain life, and (c) whose failure to perform when properly used in accordance with instructions for use provided in the labeling, can be reasonably expected to result in a significant injury of the user.*

*2. A critical component in any component of a life support device or system whose failure to perform can be reasonably expected to cause the failure of the life support device or system, or to affect its safety or effectiveness.*