



原厂直供，技术支持。 联系人：李生 电话：18126115420（微信同号） **ASC60N1200MT3**

1200V N-Channel MOSFET

Description

Silicon Carbide (SiC) MOSFET use a completely new technology that provide superior switching performance and higher reliability compared to Silicon. In addition, the low ON resistance and compact chip size ensure low capacitance and gate charge. Consequently, system benefits include highest efficiency, faster operating frequency, increased power density, reduced EMI, and reduced system size.

Features

- High Speed Switching with Low Capacitances
- High Blocking Voltage with Low RDS(on)
- Simple to drive with Standard Gate Drive
- 100% avalanche tested
- Maximum junction temperature of 150°C
- ROHS Compliant

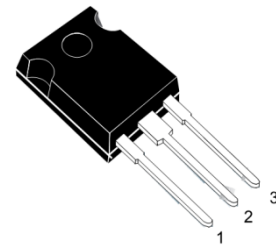

Application

- EV Charging
- DC-AC Inverters
- High Voltage DC/DC Converters
- Switch Mode Power Supplies
- Power Factor Correction Modules
- Motor Drives

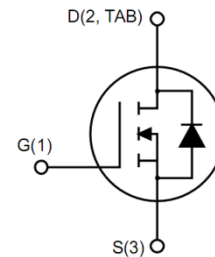

Ordering Information

Part Number	Marking	Package	Packaging
ASC60N1200MT3	ASC60N1200MT3	TO-247	Tube



原厂直供，技术支持。 联系人：李生 电话：18126115420 (微信同号) **ASC60N1200MT3**

Absolute Maximum Ratings(Tc=25°C)

Symbol	Parameter	Value	Unit
V _{DS}	Drain-Source Voltage	1200	V
I _D	Drain Current(continuous)at Tc=25°C	60	A
I _D	Drain Current(continuous)at Tc=100°C	40	A
I _{DM}	Drain Current (pulsed)	160	A
V _{GS}	Gate-Source Voltage	-10/+22	V
P _D	Power Dissipation T _C = 25°C	328	W
T _J , T _{stg}	Junction and Storage Temperature Range	-55 to +150	°C

Electrical Characteristics(T_J = 25°C unless otherwise specified)

Typical Performance-Static

Symbol	Parameter	Test Conditions	Min.	Typ.	Max.	Unit
BV _{DS}	Drain-source Breakdown Voltage	I _D =250uA, V _{GS} =0V	1200			V
I _{DSS}	Zero Gate Voltage Drain Current	V _{DS} =1200V, V _{GS} =0V, T _J =25°C			100	uA
I _{GSS}	Gate-body Leakage Current	V _{GS} =20V, V _{DS} =0V			250	nA
V _{GS(th)}	Gate Threshold Voltage	V _{DS} = V _{GS} , I _D =10mA	2		4	V
R _{DS(on)}	Static Drain-source On Resistance	V _{GS} =20V, I _D =40A		33	45	mΩ
R _G	Gate Resistance	V _{GS} =0V, f=1MHz		5		Ω

Typical Performance-Dynamic

C _{iss}	Input Capacitance	V _{DS} =800V, f=1MHz, V _{GS} =0V		1950		pF
C _{oss}	Output Capacitance			185		pF
C _{rss}	Reverse Transfer Capacitance			28		pF
Q _g	Total Gate Charge	V _{DS} =800V, I _D =40A, V _{GS} =0~20V		126		nC
Q _{gs}	Gate-source Charge			20		nC
Q _{gd}	Gate-Drain Charge			38		nC
t _{d(on)}	Turn-on Delay Time	V _{DD} =800V, I _D =40A, V _{GS} =-5V~20V, R _G =0Ω, R _L =40Ω, T _J =25°C		22		ns
t _r	Rise Time			56		ns
t _{d(off)}	Turn-off Delay Time			32		ns
t _f	Fall Time			35		ns



原厂直供，技术支持。 联系人：李生 电话：18126115420（微信同号） **ASC60N1200MT3**

Typical Performance-Reverse Diode

Symbol	Parameter	Test Conditions	Min.	Typ.	Max.	Unit
V _{FSD}	Forward Voltage	V _{GS} =0V, I _F =30A, T _J =25°C	3		6	V
		V _{GS} =0V, I _F =30A, T _J =150°C	3		6	V
t _{rr}	Reverse Recovery Time	V _{GS} =0 V, I _F =30 A, V _R =800 V, di/dt= 2000 A/us		58		ns
Q _{rr}	Reverse Recovery Charge			287		nC
I _{rrm}	Peak Reverse Recovery Current			18		A

Thermal Characteristics

Symbol	Parameter	Value.	Unit
R _{θJC}	Thermal Resistance, Junction-to-Case	0.38	°C/W
R _{θJA}	Thermal Resistance, Junction-to-Case	40	°C/W

The values are based on the junction-to case thermal impedance which is measured with the device mounted to a large heat sink assuming maximum junction temperature of T_J(max)=150°C



Electrical Characteristics (25°C unless noted)

Figure 1: Output characteristics ($T_J = 25^\circ\text{C}$)

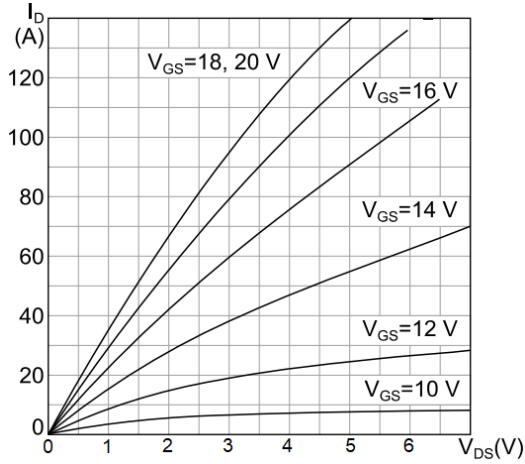

Figure 2: Output characteristics ($T_J = 150^\circ\text{C}$)

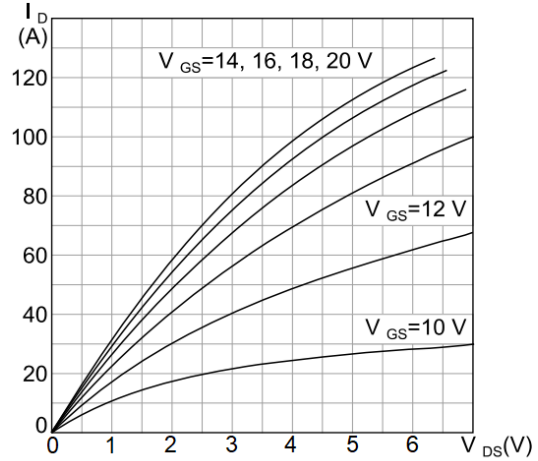

Figure 3: Transfer characteristics

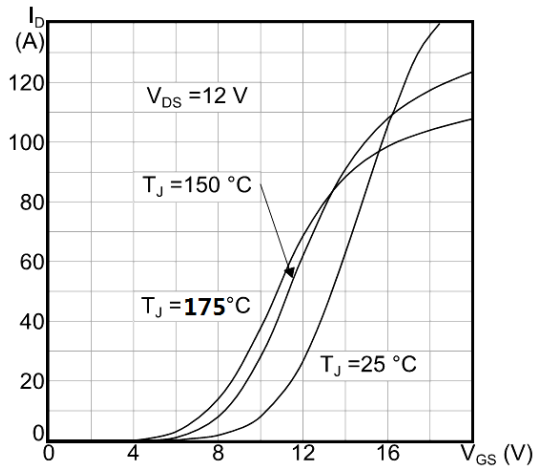

Figure 5: Power dissipation

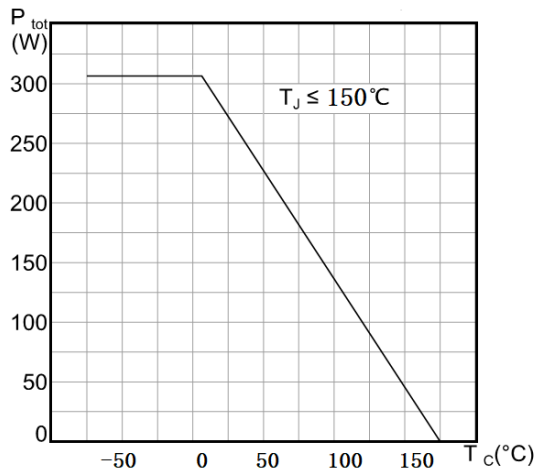

Figure 4 Normalized BVDSS vs. Temperature

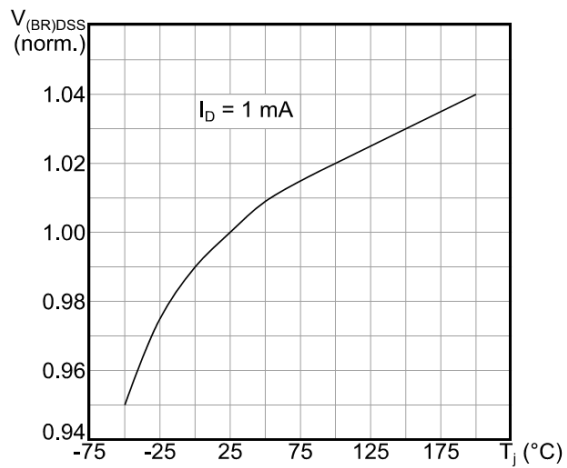
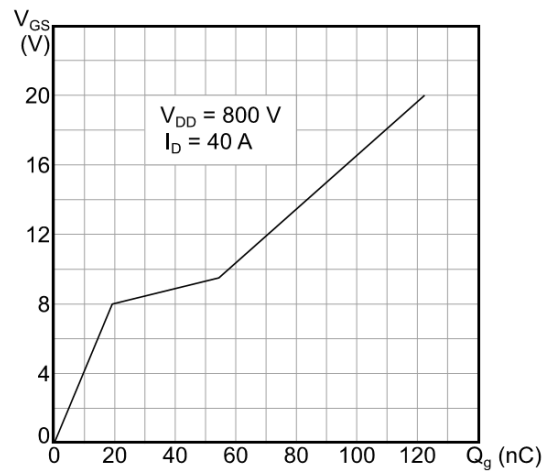

Figure 6: Gate charge vs gate-source voltage





原厂直供，技术支持。 联系人：李生 电话：18126115420 (微信同号) **ASC60N1200MT3**

Figure 7: Capacitance variations

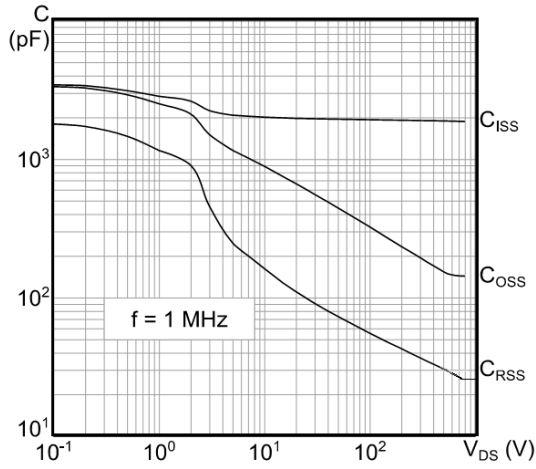

Figure 8: Switching energy vs. drain current

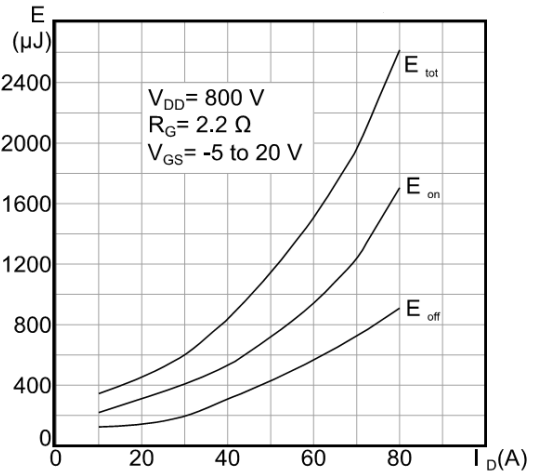

Figure 9: Normalized V_{th} vs. T_J

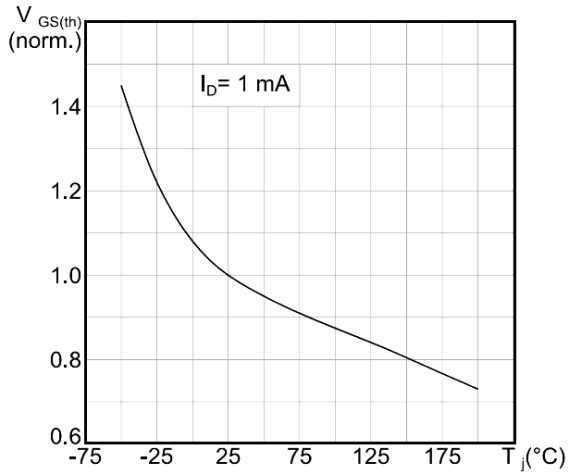

Figure 10: Normalized R_{DS(on)} vs. T_J

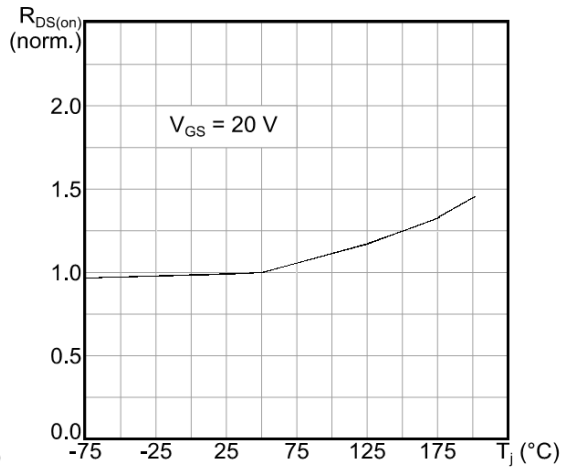

Figure 11: Body diode characteristics (T_J = 25 °C)

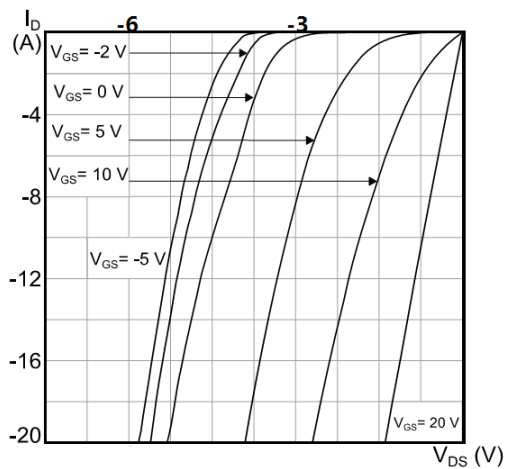
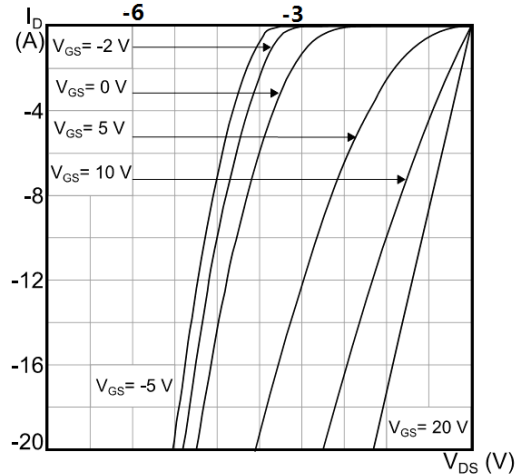

Figure 12: Body diode characteristics (T_J = 150 °C)





原厂直供，技术支持。 联系人：李生 电话：18126115420（微信同号） ASC60N1200MT3

Figure 13: Safe operating area

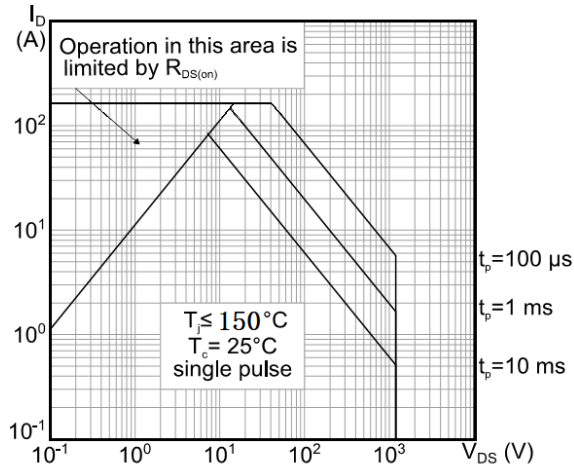

Figure 14: Continuous Ids VS Tc

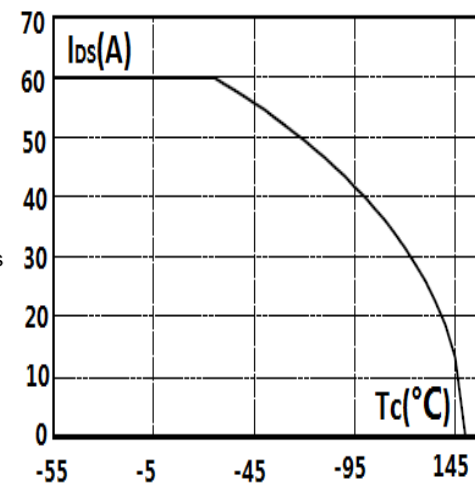
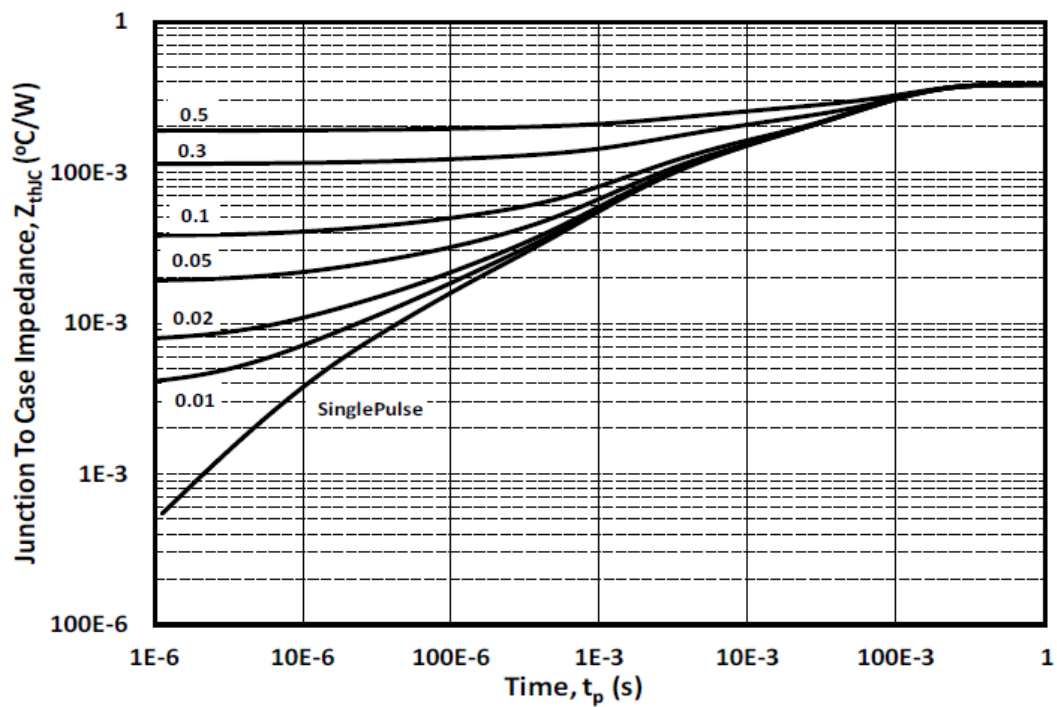

Figure 15: Thermal impedance





原厂直供，技术支持。 联系人：李生 电话：18126115420（微信同号）ASC60N1200MT3

Package Drawing:

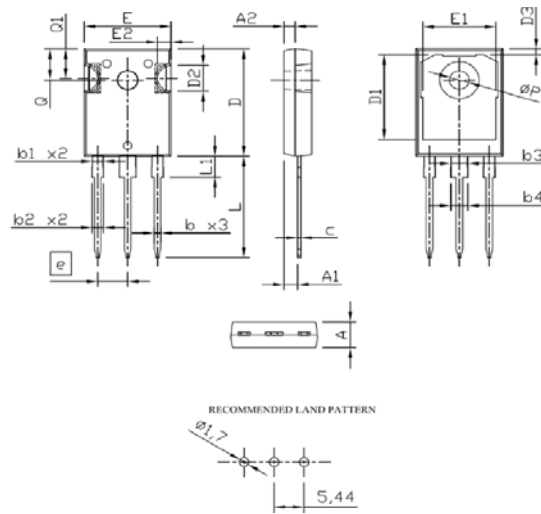

Dimensions (UNIT: mm)

SYMBDLS	DIMENSIONS IN MILLIMETERS			DIMENSIONS IN INCHES		
	MIN	NOM	MAX	MIN	NOM	MAX
A	4.90	5.00	5.10	0.193	0.197	0.201
A1	2.31	2.42	2.52	0.091	0.095	0.099
A2	1.90	2.00	2.10	0.075	0.079	0.083
b	1.16	1.22	1.27	0.046	0.048	0.050
b1	1.96	2.02	2.07	0.078	0.080	0.081
b2	2.00	2.10	2.20	0.079	0.083	0.087
b3	2.96	3.02	3.07	0.117	0.119	0.121
b4	3.00	3.10	3.20	0.118	0.122	0.126
C	0.59	0.62	0.66	0.023	0.024	0.026
D	20.90	21.00	21.10	0.823	0.827	0.831
D1	16.25	16.55	16.85	0.640	0.652	0.663
D2	5.00 TYP			0.197 TYP		
D3	1.05	1.20	1.35	0.041	0.047	0.053
e	5.44 BSC			0.214 BSC		
E	15.70	15.80	15.90	0.618	0.622	0.626
E1	13.06	13.26	13.50	0.514	0.522	0.530
E2	2.50 TYP			0.098 TYP		
L	19.72	19.92	20.12	0.776	0.784	0.792
L1	—	—	4.30	—	—	0.169
Q	6.15 BSC			0.242BSC		
Q1	5.60	5.80	6.00	0.220	0.228	0.236
ØP	3.55	3.60	3.70	0.140	0.142	0.146