

产品规格书

G5139P-36W-12V3.0A

描述(Description): 12V3A G5139P

客户(Customer): GS

版本(Version): V1.0

发行日期(Iss Date): 2020-08-25

| 拟制 PREPARED BY | 检查 CHECKED BY | 批准 APPROVED BY |
|----------------|---------------|----------------|
| | | |



深圳市福田区上梅林中康路奥士达大厦A座312-316室
ADD:Scotia Centre, 4th Floor, P. O. Box 2840, George Town, Grand Cayman KY1-1112, Cayman Islands
TEL: 86 0755-82662217 82662215 FAX: 86 0755-82668680

| 日期 Date | 变更内容 Modify Item | | 变更依据 Modify Reason | 版本 Rev |
|---|---------------------|-------|---|-----------|
| 模拟PSR | G1132NS | SOP-8 | 内置MOSFET 6W、六级能效、待机70mW内、保护功能全、INV内置输出过压保护、4KV ESD | |
| 模拟PSR | G1135NS | SOP-8 | 内置MOSFET 12W、六级能效、待机70mW内、保护功能全、INV内置输出过压保护、4KV ESD | |
| 模拟PSR | G1135NSA | SOP-8 | 内置MOSFET 13W、六级能效、待机70mW内、保护功能全、INV内置输出过压保护、4KV ESD | |
| 模拟PSR | G1135NSB | SOP-8 | 内置MOSFET 14W、六级能效、待机70mW内、保护功能全、INV内置输出过压保护、4KV ESD | |
| 模拟PSR | G1135NSC | SOP-8 | 内置MOSFET 16W、六级能效、待机70mW内、保护功能全、INV内置输出过压保护、4KV ESD | |
| 模拟PSR | G1135NSD | SOP-8 | 内置MOSFET 20W、六级能效、待机70mW内、保护功能全、INV内置输出过压保护、4KV ESD | |
| 模拟PSR | G1135FSC | SOP-7 | 内置MOSFET 16W、六级能效、待机70mW内、保护功能全、输入过压欠压保护、精准可调输出过压保护、4KV ESD | |
| 模拟PSR | G1135FSD | SOP-7 | 内置MOSFET 20W、六级能效、待机70mW内、保护功能全、输入过压欠压保护、精准可调输出过压保护、4KV ESD | |
| 模拟PSR | G1135PS | DIP-7 | 内置MOSFET 15W、六级能效、待机70mW内、保护功能全、输入过压欠压保护、精准可调输出过压保护、4KV ESD | |
| 模拟PSR | G1138PS | DIP-7 | 内置MOSFET 18W、六级能效、待机70mW内、保护功能全、输入过压欠压保护、精准可调输出过压保护、4KV ESD | |
| 模拟PSR | G1138PSA | DIP-7 | 内置MOSFET 25W、六级能效、待机70mW内、保护功能全、输入过压欠压保护、精准可调输出过压保护、4KV ESD | |
| 模拟PSR | G1138PSC | DIP-7 | 内置MOSFET 22W、六级能效、待机70mW内、保护功能全、输入过压欠压保护、精准可调输出过压保护、4KV ESD | |
| 模拟 SSR | G1559-01 | DIP-8 | 内置MOSFET 25W, 3K的ESD, 待机100mW, FB脚可靠 | |
| | | | | |
| | | | | |
| | | | | |
| | | | | |
| | | | | |
| | | | | |
| | | | | |
| | | | | |
| | | | | |
| | | | | |
| | | | | |
| | | | | |
| | | | | |
| | | | | |
| | | | | |
|  环球半导体 Global Semiconductor | | | | |
| 深圳市福田区上梅林中康路奥士达大厦A座312-316室 ADD:Scotia Centre, 4th Floor, P. O. Box 2840, Geoge Twon, Grangd Cayman KY1-1112, Cayman Islangds TEL: 86 0755-82662217 82662215 FAX: 86 0755-82668680 | | | | |

Section 目录

1. Input Characteristics/输入特性

- 1.1 Input Voltage & Frequency/输入电压&频率
- 1.2 Input AC Current/AC 输入电流
- 1.3 Inrush Current (Cold Start)/浪涌电流(冷启动)
- 1.4 Efficiency (Normal)/效率(额定输入)
- 1.5. No Load Power Consumption /空载功耗

2. Output Characteristics/输出特性

- 2.1 Static Output Characteristics <V_o & R+N>/静态输出特性
- 2.2 Line / Load Regulation/线性/负载调整率
- 2.3 Turn on Delay Time/开机延迟时间
- 2.4 Hold up Time/关机维持时间
- 2.5 Rise Time/上升时间
- 2.6 Output Overshoot / Undershoot/输出过冲/欠冲
- 2.7 Output Load Transient Response/输出负载瞬态响应

3. Protection Requirements/保护特性

- 3.1 Over Current Protection/过流保护
- 3.2 Short Circuit Protection/短路保护
- 3.3 Over Voltage Protection/过压保护

4. Environment Requirements/环境要求

- 4.1 Operating Temperature and Relative Humidity/操作温/湿度要求
- 4.2 Storage Temperature and Relative Humidity/存储温/湿度要求
- 4.3 Burn-in/老化
- 4.4 Cryogenic Storage/低温存储
- 4.5 Vibration/振动
- 4.6 Drop in/跌落

5. Reliability Requirements/可靠性要求

- 5.1 MTBF Qualification/平均间隔故障时间估算
- 5.2 Salt test/盐雾测试

6. EMI/EMS Standards/EMI/EMS 标准

- 6.1 EMI Standards/EMI 标准
- 6.2 EMS Standards/EMS 标准

7. Safety Standards/安规标准

- 7.1 Dielectric Strength(Hi-pot)/介电耐压强度(高压)
- 7.2 Leakage Current/漏电流
- 7.3 Insulation Resistance/绝缘阻抗
- 7.4 Regulatory Standards/安规标准

8. Schematic (原理图)

9. PCB LAYOUT

10. Bill of material (物料清单)

11. Test report (测试报告)

- 11.1 Electrical performance test report (电性能测试报告)
- 11.2 Temperature test report (温升测试报告)
- 11.3 V_{ds} Waveform (开关管V_{ds})
- 11.4 Output Diode's Voltage waveform(肖特基V_r)
- 11.5 Ripple and Noise Testing Waveform (纹波以及噪音测试)
- 11.6 Turn-on Delay Time and Hold Up Time Waveform (开机时间与关机时间测试)
- 11.7 Over-Voltage Protection Waveform (输出过电压保护)
- 11.8 Dynamic Load Response Waveform(动态响应测试)
- 11.9 Rise Time and Output Overshoot Waveform(上升时间和输出过冲)
- 11.10 Inrush Current (Cold Start) Waveform
- 11.11 Transformer Flux Density (变压器磁通量)

12. EMC test report (EMC测试报告)

13. Transformer specifications (变压器规格书)



深圳市福田区上梅林中康路奥士达大厦A座312-316室
ADD: Scotia Centre, 4th Floor, P. O. Box 2840, George Town, Grand Cayman KY1-1112, Cayman Islands
TEL: 86 0755-82662217 82662215 FAX: 86 0755-82668680

1. Input Characteristics/输入特性

1.1. Input Voltage & Frequency/输入电压与频率

The range of input voltage is from 90Vac to 264Vac single phase, can start and work normally with all kind of load:85-90Vac, can start and work normally with 100% load

输入电压范围: 从 90Vac 到 264Vac, 单相输入, 各种负载下, 能正常启动并工作;
85-90Vac, 带 100% 负载能正常启动并工作

| Input Voltage/输入电压 | Minimum/最小 | Nominal/额定值 | Maximum/最大 |
|----------------------|------------|---------------|------------|
| Input Frequency/输入频率 | 90Vac | 100Vac~240Vac | 264Vac |
| Input Frequency/输入频率 | 50Hz | 60Hz/50Hz | 60Hz |

1.2. Input AC Current/AC 输入电流

0.7 Amax. @ 90-264Vac input & Full load/满载

1.3. Inrush Current (cold start)/浪涌电流(冷启动)

60 Amax. @ 264Vac input & Full load/264Vac 输入, 满载

1.4. Energy Consumption /平均效率

88.3% min. @ 115V & 230Vac input & 100% Load; 75% Load; 50% Load; 25% Load

1.5. No Load Power Consumption /空载功耗

0.075 Wmax. @ 230Vac input & No load/空载

2. Output Characteristics/输出特性

2.1 Static Output Characteristics <Vo & R+N>/静态输出特性

| Output | Rated Load/额定负载 | | Output Range 输出电压范围 | R+N 纹波与噪声 | Remark 备注 |
|--------|-----------------|-----------|------------------------|--------------|--------------|
| | Rate | Min. Load | | | |
| 12V | 0.0A | 3A | 11.40V ~ 12.60V | 120mVp-p | AC: 90-264V |

Ripple & Noise: Measurement is done by 20MHz bandwidth oscilloscope and the output paralleled a 0.1uF ceramic capacitor and a 10uF electrolysis capacitor. (test under the condition of rated input and rated output)

纹波与噪声: 量测时示波器选用 20MHz 带宽限制, 输出端要并联一颗 0.1uF 的陶瓷电容和一颗 10uF 的电解电容. (在额定输入及输出的条件下检测)

2.2. Line/ Load Regulation/线性/负载调整率

| Output | Load Condition/负载条件 | | Line Regulation 线性调整率 | Load Regulation 负载调整率 | Remark 备注 |
|--------|---------------------|-----------|--------------------------|--------------------------|--------------|
| | Rate | Min. Load | | | |
| 12V | 0.0A | 3A | ± 1.5% | ± 5% | |

2.3. Turn - on Delay Time/开机延迟时间

3S max. @ 90Vac input & Full load/90Vac 输入, 满载

2.4. Hold-up Time/关机维持时间

30mS min. @ Full load & 90Vac/90Vac 输入, 满载

2.5. Rise Time/上升时间

30mS max. @ 90Vac input & Rated load, output voltage from 10% to 90%.

230Vac 输入, 额定负载, 输出电压从 10% 上升至 90%

2.6. Output Overshoot /输出过冲

12.6V max. When the power on, when it is the full input voltage and full load

当电源开时, 输入全电压时, 全负载时, 输出电压小于 12.6V

2.7. Output Load Transient Response/输出负载瞬态响应

Oscilloscope Coupling AC : ≤ 1500mV, the load changes from 10% to 100% to 10%, 0.1A/uS, slope dynamic response recovery time: 1mS

示波器耦合 AC: ≤ 1500mV, 负载变化: 从 10% to 100% to 10%, 斜率: 0.1A/uS, 动态响应恢复, 时间: 1mS



深圳市福田区上梅林中康路奥士达大厦A座312-316室
ADD: Scotia Centre, 4th Floor, P. O. Box 2840, George Town, Grand Cayman KY1-1112, Cayman Islands
TEL: 86 0755-82662217 82662215 FAX: 86 0755-82668680

3. Protection Requirements/保护要求

3.1. Over Current Protection/过流保护

OCP Point Limited/过流点限制: > 3.6A (90-264Vac)

注: 在整过设计电压范围 AC90~264V 内, 测试的过流点差值小于 0.4A

The output shall hiccup when the over currents applied to the output rail, and shall be self-recovery when the fault condition is removed.
当过电流时,输出将进入打嗝模式,当过流情况解除后,产品可以自动恢复并正常工作。

3.2. Short Circuit Protection/短路保护

when the output is short circuit, the power is in the hiccup restart state. Shall be self-recovery and work normally when the fault condition is removed

当输出短路时,电源处于打嗝重启状态。当短路情况解除后,产品可以自动恢复并正常工作

3.3. Over Voltage Protection/过压保护

Short open circuit primary sampling pull-down resistance, the power shall have protection. And the output voltage is less than 16V. Under fault conditions, the power supply can't be exploded, smoking, on fire.

当初级采样下拉电阻或开环, 电源进入保护状态, 输出电压瞬时值小于 16V。在故障条件下, 不能有爆炸, 冒烟, 起火等任何安全问题发生。

4. Environment Requirements/环境要求

4.1. Operating Temperature and Relative Humidity/操作温/湿度要求

-10°C to 40°C

10%RH to 95%RH

4.2. Storage Temperature and Relative Humidity/存储温/湿度要求

-20°C to +70°C

5%RH to 95%RH non-condensing @ Sea level shall be low 10,000 feet/低于 10,000 英尺

4.3. Burn-in/老化

The power supply shall be burn-in for 4 Hours under nor. input and 100% max. load at 40°C~45°C

产品至少要在 40°C~45°C 的环境, 额定输入及 100%最大负载条件下老化 4 小时。

4.4. Cryogenic Storage/低温存储

In the -15°C, under the condition of no electricity storage for 4 hours, the adapter can turn on, and work normally, the output voltage is normal

在 -15°C, 不通电条件下存储 4 小时后, 适配器通电能开机工作正常, 输出电压正常

4.5. Vibration/振动

10 to 300Hz sweep at a constant acceleration of 1.0G(Breadth: 3.5mm) for 1Hour for each of the perpendicular axes X, Y, Z,

there should not be damaged on the appearance, and an work normally.

扫描频率: 10 to 300Hz, 加速度: 1.0G(位移: 3.5mm), X, Y, Z 三垂直坐标轴向各振动 1 小时,外观无损毁,能正常工作

4.6. Drop in/跌落

1 corner, 3 edges, 6 surfaces each once. Height: 100cm, On the wooden board, the plug can be bend, and scratch, but the structure should not be damaged, no noise when sway, and can work normally.

一角, 三棱, 六面, 跌落高度: 1 米, 各一次, 跌落到木板上, 插脚可以弯曲, 外壳可以有刮伤, 但外观不能有结构性损坏, 晃动无响声, 能正常工作



深圳市福田区上梅林中康路奥士达大厦A座312-316室
ADD: Scotia Centre, 4th Floor, P. O. Box 2840, George Town, Grand Cayman KY1-1112, Cayman Islands
TEL: 86 0755-82662217 82662215 FAX: 86 0755-82668680

5. Reliability Requirements/可靠性要求

5.1. MTBF Qualification/平均间隔故障时间估算

The MTBF shall be at least 50,000 hours at 25°C, Full load and nominal input condition
平均间隔故障时间: 至少 50,000 小时, 25°C 环境及额定输入与满载条件下

5.2. Salt test/盐雾测试

Putting the sample in the salt 5% with 24 hours, and the electronic test is OK after the test.

将样品放入盐雾浓度为 5% 的盐雾箱内测试 24 小时, 测试完成后电气功能正常。

6. EMI/EMS Standards/EMI/EMS 标准

6.1 EMI Standards/EMI 标准

GB13837; GB9254;
EN 55032

6.2. EMS Standards/EMS 标准

EN 55035

6.2.1 EN 61000-4-2, electrostatic discharge(ESD) requirement/静电抗扰度要求

| Discharge characteristic/静电规格 | Test level/测试条件 | Test criteria/测试标准 |
|-------------------------------|-----------------|--------------------|
| Air discharge/空气放电 | "±-16KV | B |
| Contact discharge/接触放电 | "±-8KV | B |

6.2.2 EN 61000-4-3, radiated electromagnetic field susceptibility(rs)/辐射骚扰场强

| Test level/测试条件 | Test criteria/测试标准 |
|-----------------|--------------------|
| 3V/m (r.m.s) | A |

80-1000MHz, 80%AM(1KHz) sine-wave

6.2.3 EN 61000-4-4, electric fast transients(burst) immunity requirement/电快速瞬变脉冲群

| Coupling/测试端口 | Test level/测试条件 | Test criteria/测试标准 |
|---------------|-----------------|--------------------|
| AC-input/交流输入 | 0.5KV | A |
| AC-input/交流输入 | 1KV | B |

6-2-4 EN 61000-4-5, surge capability requirement/浪涌抗扰度要求

| Surge voltage/雷击电压 | Test criteria/测试标准 |
|----------------------------|--------------------|
| Common mode/共模 ±-4KV | A |
| Differential mode/差模 ±-2KV | |

6-2-5 EN 61000-4-6, Induced radio frequency fields conducted disturbances immunity requirement/电源端子传导骚扰实验

| Test level/测试条件 | Test criteria/测试标准 |
|--------------------------|--------------------|
| 3V | A |
| 0.15-80 MHz, 80%AM(1KHz) | |

7. Safety Standards/安规标准

7.1 Dielectric Strength(Hi-pot)/介电耐压强度(高压)

Primary to Secondary: 3000Vac 50Hz / 5mAmax / 60second(3second for production) should not be breakdown and flashover.

初级对次级: 3000Vac 50Hz / 5mAmax / 60 秒(生产时高压测试时间: 3 秒), 无击穿或飞弧现象

7.2. Leakage Current/漏电流

0.25mAmax. at 230Vac / 50Hz

7.3. Insulation Resistance/绝缘阻抗

100MΩ min. at primary to secondary add 500Vdc test voltage, Relative Humidity 90%.

在初级与次级间加 500Vdc 进行测试, 绝缘阻抗大于 100 MΩ, 相对湿度为 90%



深圳市福田区上梅林中康路奥士达大厦A座312-316室
ADD: Scotia Centre, 4th Floor, P. O. Box 2840, George Town, Grand Cayman KY1-1112, Cayman Islands
TEL: 86 0755-82662217 82662215 FAX: 86 0755-82668680

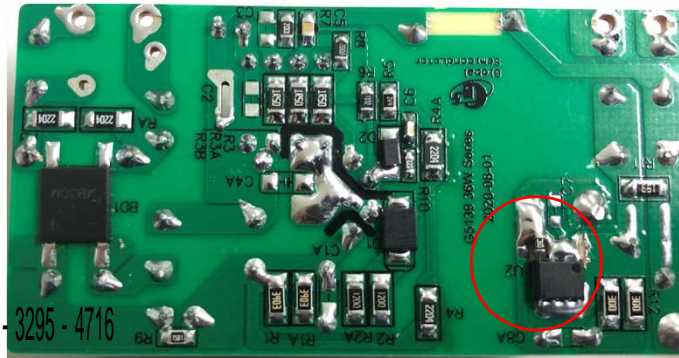

张小姐 133-3295-4716

输出同步
整流芯片

36W-12V3A整机电源底面



安规变压器

EMI元件和防雷
击和防浪涌

输出储能电容

G5139P

安规保险丝 张小姐 133-3295-4716 安规Y电容

36W-12V3A整机电源顶面



环球半导体
Global Semiconductor

深圳市福田区上梅林中康路奥士达大厦A座312-316室
ADD: Scotia Centre, 4th Floor, P. O. Box 2840, George Town, Grand Cayman KY1-1112, Cayman Islands
TEL: 86 0755-82662217 82662215 FAX: 86 0755-82668680

36W-12V3A整机电源原理图

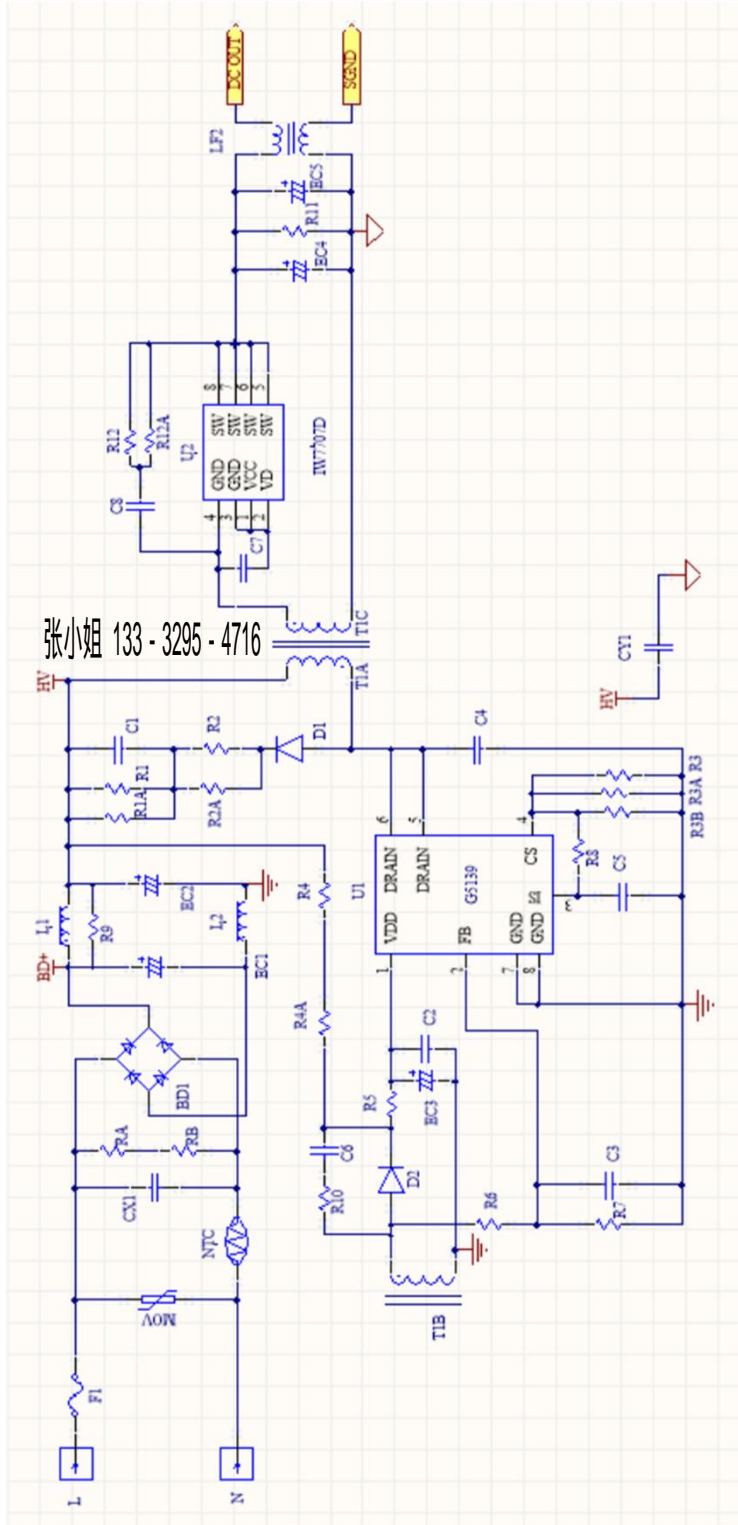

深圳市福田区上梅林中康路奥士达大厦A座312-316室
ADD: Scotia Centre, 4th Floor, P. O. Box 2840, George Town, Grand Cayman KY1-1112, Cayman Islands
TEL: 86 0755-82662217 82662215 FAX: 86 0755-82668680

11. Test report (测试报告)

| | |
|-------|----------------------|
| MODEL | |
| SPEC | 12V/3A |
| INPUT | 90V/60HZ - 264V/50HZ |

| | |
|-----------|------------|
| DATE | 2020/08/25 |
| TESTED BY | |
| Ta | 25°C |

Remark:

11.1 Electrical performance test report (电性能测试报告) 线端测试: 20#*1.8M

| NO. 1 | Load Rate | Pin (W) | Vout (V) | Iout (mA) | Pout (W) | η (%) | OCP (A) | Average η(%) |
|--------|-----------|---------|----------|-----------|----------|--------|---------|--------------|
| 90Vac | Iput: 0 | 0.050 | 12.100 | 0.000 | | | 3.62 | 88.51% |
| | 10% | 4.051 | 12.060 | 0.300 | 3.618 | 89.31% | | |
| | 25% | 9.970 | 12.000 | 0.750 | 9.000 | 90.27% | | |
| | 50% | 19.940 | 11.890 | 1.500 | 17.835 | 89.44% | | |
| | 75% | 30.110 | 11.780 | 2.250 | 26.505 | 88.03% | | |
| | 100% | 40.560 | 11.670 | 3.000 | 35.010 | 86.32% | | |
| 115Vac | Iput: 0 | 0.053 | 12.100 | 0.000 | | | 3.64 | 89.20% |
| | 10% | 4.058 | 12.060 | 0.300 | 3.618 | 89.16% | | |
| | 25% | 9.940 | 12.000 | 0.750 | 9.000 | 90.54% | | |
| | 50% | 19.850 | 11.890 | 1.500 | 17.835 | 89.85% | | |
| | 75% | 29.830 | 11.780 | 2.250 | 26.505 | 88.85% | | |
| | 100% | 39.990 | 11.670 | 3.000 | 35.010 | 87.55% | | |
| 230Vac | Iput: 0 | 0.083 | 12.100 | 0.000 | | | 3.68 | 89.08% |
| | 10% | 4.194 | 12.060 | 0.300 | 3.618 | 86.27% | | |
| | 25% | 10.050 | 12.000 | 0.750 | 9.000 | 89.55% | | |
| | 50% | 19.890 | 11.890 | 1.500 | 17.835 | 89.67% | | |
| | 75% | 29.800 | 11.780 | 2.250 | 26.505 | 88.94% | | |
| | 100% | 39.720 | 11.670 | 3.000 | 35.010 | 88.14% | | |
| 264Vac | Iput: 0 | 0.122 | 12.100 | 0.000 | | | 3.67 | 88.44% |
| | 10% | 4.172 | 12.060 | 0.300 | 3.618 | 86.72% | | |
| | 25% | 10.150 | 12.000 | 0.750 | 9.000 | 88.67% | | |
| | 50% | 20.020 | 11.890 | 1.500 | 17.835 | 89.09% | | |
| | 75% | 29.960 | 11.780 | 2.250 | 26.505 | 88.47% | | |
| | 100% | 40.000 | 11.670 | 3.000 | 35.010 | 87.53% | | |

张小姐 133 - 3295 - 4716

36W-12V3.0A整机电源能源测试

11.2 Temperature test report (温升测试报告)

测试条件:

- 1..AC Input: 90V/60Hz, 264V/50Hz
- 2..Output Load: 12V3A
- 3..Ta: 40°C

| Item | Output:12V3A | | | |
|-------------------------|--------------|--------|------------|--------|
| | Vin=90Vac | | Vin=264Vac | |
| | T(°C) | Tr(°C) | T(°C) | Tr(°C) |
| Transformer core (RM10) | 96.69 | 56.18 | 90.5 | 50.5 |
| Transformer coil (RM10) | 104 | 63.49 | 95.2 | 55.2 |
| U1(G5139P) 点散热胶 | 115 | 74.49 | 96 | 56 |
| U2(W7707D) | 117 | 76.49 | 119 | 79 |
| EC2(33uF/400V) | 96 | 96 | 85 | 45 |
| EC4(1500uF/25V) | 86 | 45.49 | 79 | 39 |
| BD1 | 102 | 61.49 | 82 | 42 |
| Ambient Temperatur | 40.51 | | 40 | |

张小姐 133 - 3295 - 4716

40度环境温度
下元件温度测试



深圳市福田区上梅林中康路奥士达大厦A座312-316室
ADD:Scotia Centre, 4th Floor, P. O. Box 2840, Geoge Twon, Grand Cayman KY1-1112, Cayman Islangds
TEL: 86 0755-82662217 82662215 FAX: 86 0755-82668680

电源MOS @90V和264V输入时承受的电压

11.3 Vds Waveform (开关管Vds)

测试条件:

- 1.. AC Input: 90V/60Hz, 264V/50Hz
- 2.. Output Load: 12V3A
- 3.. Ta: 25°C
- 4.. Remark:

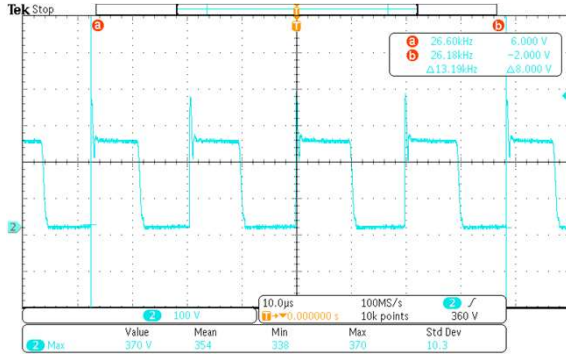

90Vac Full Load Vds(max) : 370V

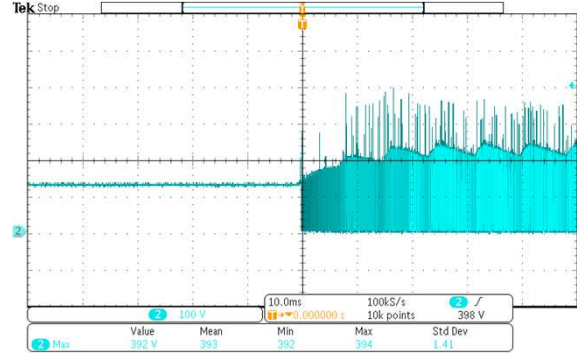

90Vac Turn On Vds(max) : 392V

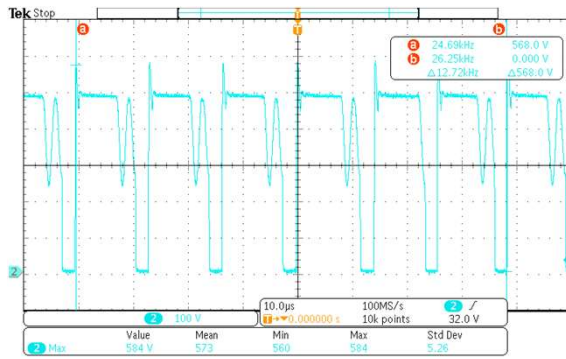

264Vac Full Load Vds(max) : 584V

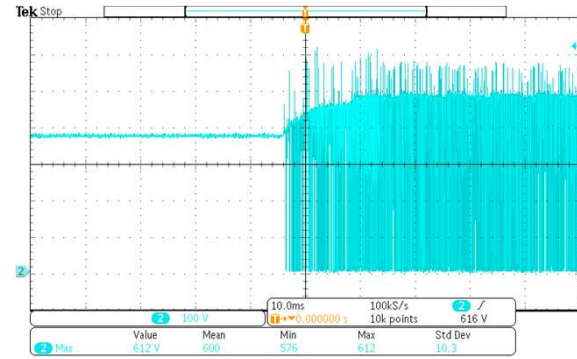

264Vac Turn On Vds(max) : 612V

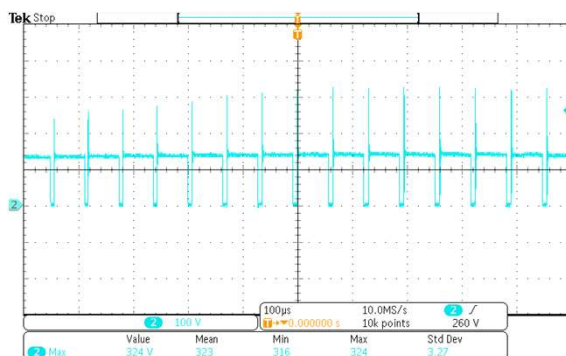

90Vac Operating Short Vds(max) : 324V

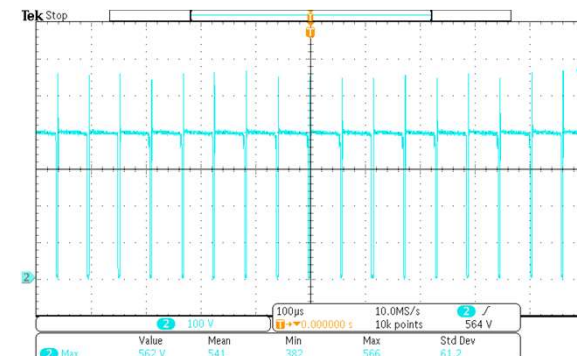

264Vac Operating Short Vds(max) : 562V



深圳市福田区上梅林中康路奥士达大厦A座312-316室
 ADD: Scotia Centre, 4th Floor, P. O. Box 2840, Geogee Twn, Grand Cayman KY1-1112, Cayman Islands
 TEL: 86 0755-82662217 82662215 FAX: 86 0755-82668680

电源同步MOS@90V和264V输入时承受的电压

11.4 Output Diode's Voltage waveform(肖特基Vrr)

测试条件:

- 1.. AC Input: 90V/60Hz, 264V/50Hz
- 2.. Output Load: 12V3A
- 3.. Ta: 25°C
- 4.. Remark:

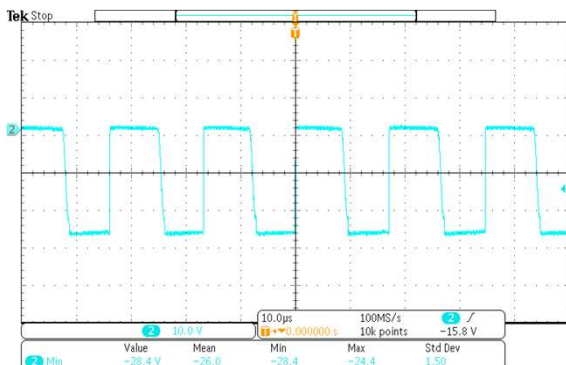

90Vac Full Load Vrr(min) : 28.4V

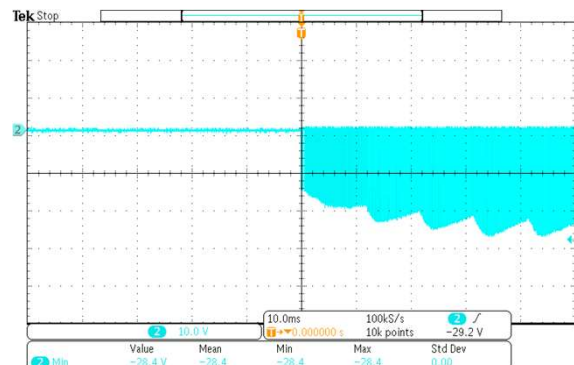

90Vac Turn On Vrr(min) : 28.4V

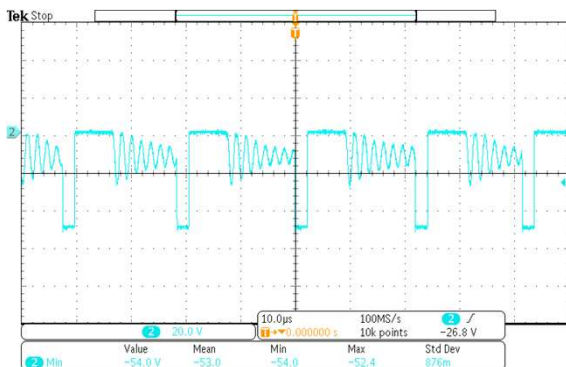

264Vac Full Load Vrr(min) : 54V

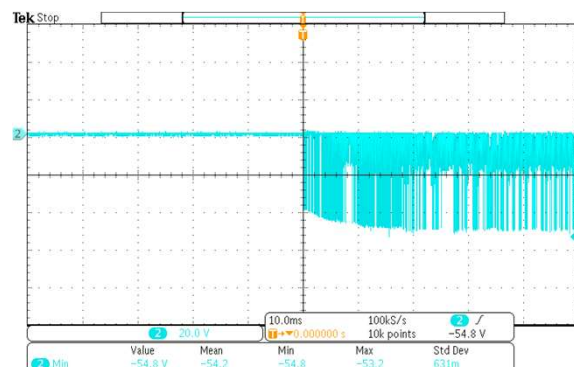

264Vac Turn On Vrr(min) : 54.8V

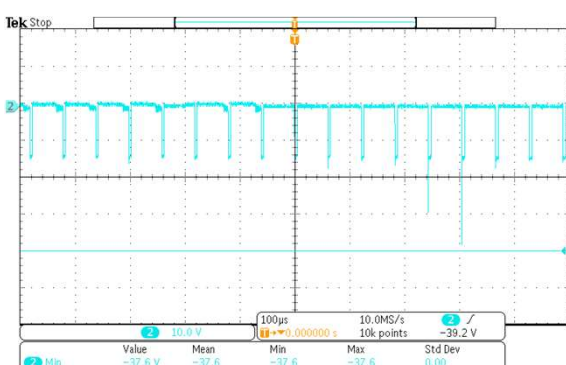

90Vac Operating short Vrr(min) : 37.6V

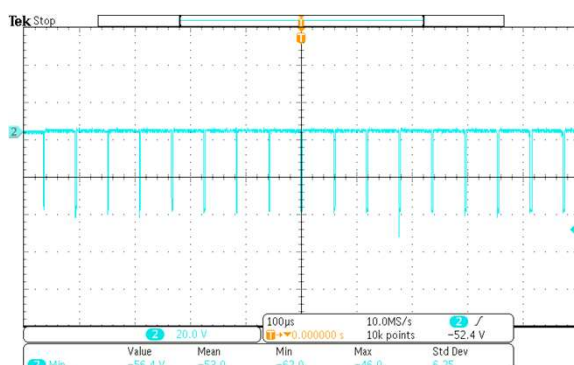

264Vac Operating short Vrr(min) : 56.4V



深圳市福田区上梅林中康路奥士达大厦A座312-316室
 ADD:Scotia Centre, 4th Floor, P. O. Box 2840, Geoge Twon, Grand Cayman KY1-1112, Cayman Islandgs
 TEL: 86 0755-82662217 82662215 FAX: 86 0755-82668680

电源在 @90V和264V输入时的纹波和杂讯

11.5 Ripple and Noise Testing Waveform (纹波以及噪音测试)

测试条件:

- 1.. AC Input: 90V/60Hz / 230V/50Hz 264V/50Hz
- 2.. Output Load: 12V3A
- 3.. Ta: 25°C
- 4.. Remark, $V_{p-p} \leq 120mV$

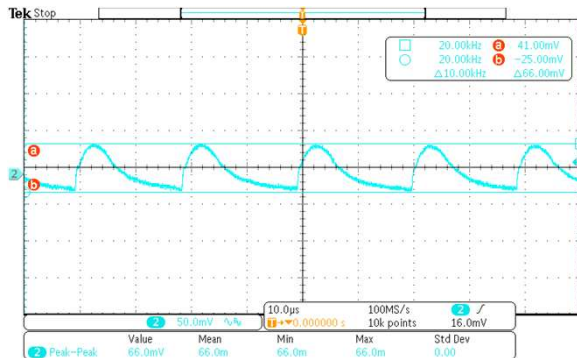

90Vac Full Load Ripple: 66mV

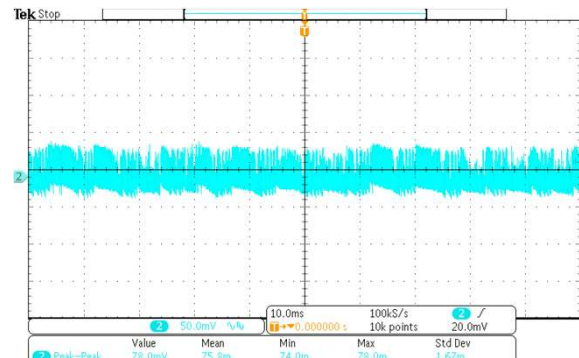

90Vac Full Load Noise: 78mV

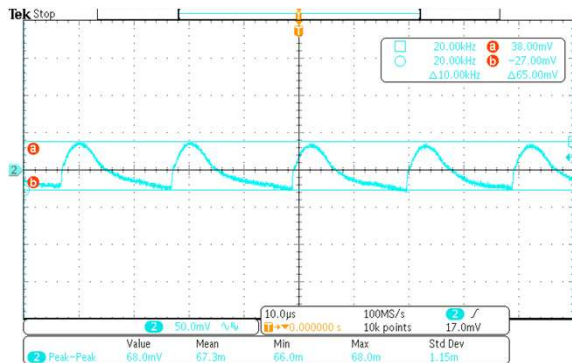

230Vac Full Load Ripple: 68mV

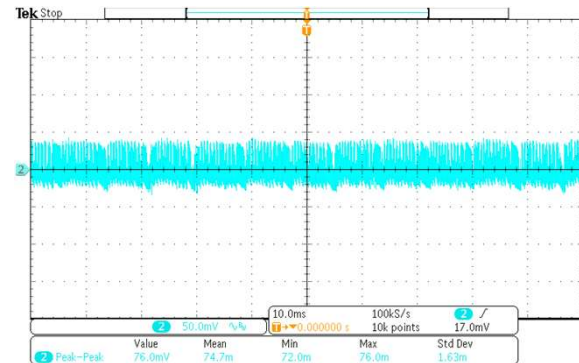

230Vac Full Load Noise: 76mV

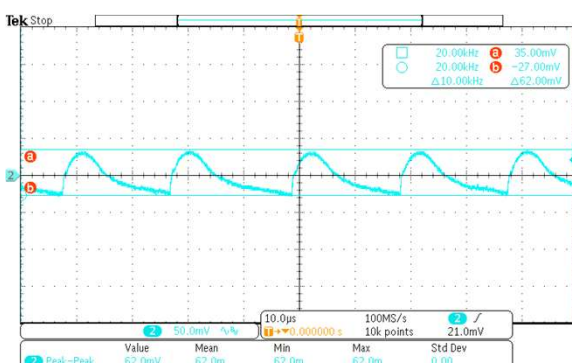

264Vac Full Load Ripple: 62mV

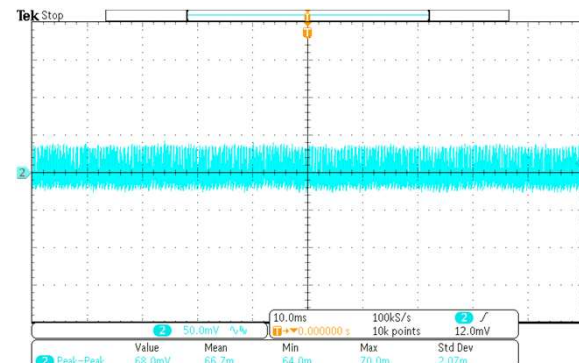

264Vac Full Load Noise: 68mV



深圳市福田区上梅林中康路奥士达大厦A座312-316室
 ADD: Scotia Centre, 4th Floor, P. O. Box 2840, Geogee Twn, Grand Cayman KY1-1112, Cayman Islands
 TEL: 86 0755-82662217 82662215 FAX: 86 0755-82668680

11.6 Turn-on Delay Time AND Hold Up Time Waveform (开机时间与关机保持时间测试)

测试条件:

- 1..AC Input: 90V/60Hz
- 2..Output Load: 12V3A
- 3..Ta: 25°C
- 4..Remark:

电源开机时间

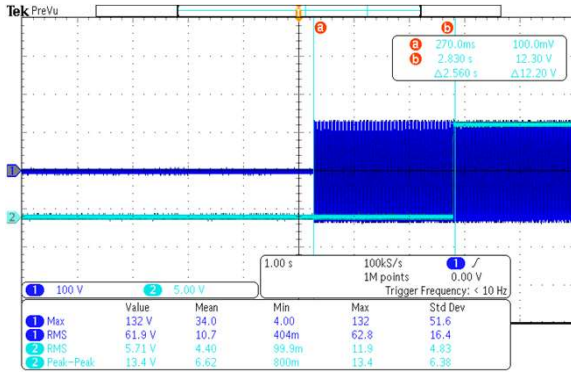

90Vac Full Load Turn-on Delay Time: 2.56S

11.12 Transformer Flux Density (变压器磁通量)

测试条件:

- 1..AC Input:90V/60Hz
- 2..Output Load:12V3A
- 3..Ta: 25°C

电源在 @90V输入时的变压器B值

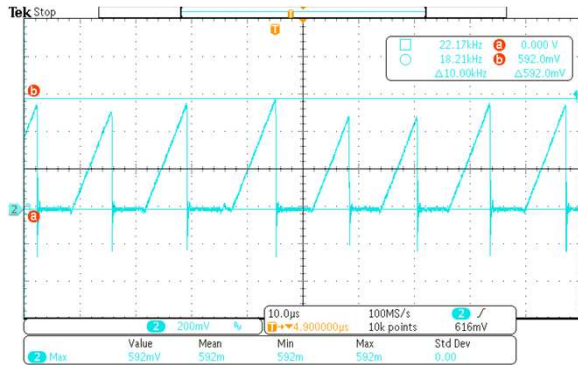

90Vac Full Load Vds(max) : 592mV

$N_p:45T, L_p:600\mu H, A_e=89mm^2, R_{cs}=0.5$

$B_{max} = (V_{cs} * L_p) / (N_p * A_e * R_{cs})$

$= (0.592 * 800) / (45 * 89 * 0.50)$

$= 0.25$

张小姐 133 - 3295 - 4716

11.13 Inrush Current (Cold Start)Waveform/浪涌电流(冷启动)

测试条件:

- 1..264Vac input & Full load
- 2..Output Load: 12V3A
- 3..Ta: 25°C
4. REMRAK : $\leq 60A$

电源在 @264V输入时浪涌电流

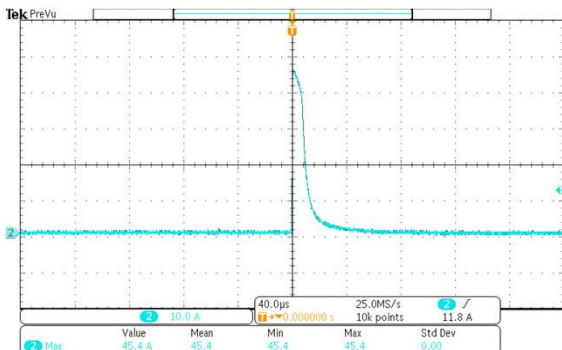

264V FULL LOAD 45.4A 张小姐 133 - 3295 - 4716



深圳市福田区上梅林中康路奥士达大厦A座312-316室
 ADD:Scotia Centre, 4th Floor, P. O. Box 2840, George Town, Grand Cayman KY1-1112, Cayman Islands
 TEL: 86 0755-82662217 82662215 FAX: 86 0755-82668680

电源在 @90V和264V输入时的动态负载

11.8 Dynamic Load Response Waveform(动态响应测试)

测试条件:

- 1.. AC Input: 90V/60Hz, 230V/50Hz, 264V/50Hz
- 2.. Output Load: 12V3A
- 3.. Ta: 25°C
- 4.. Load:

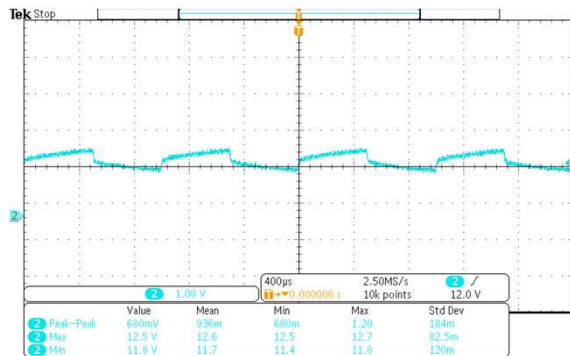

90Vac Oscilloscope Coupling AC: 680mV

张小姐 133 - 3295 - 4716

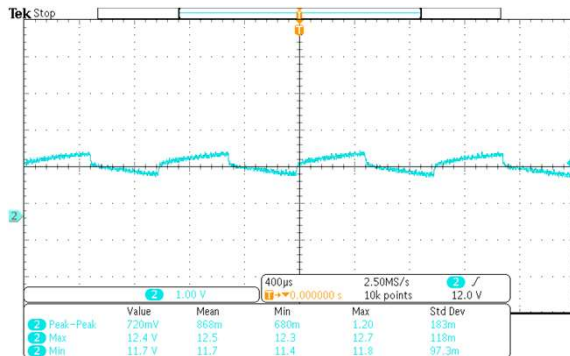

230Vac Oscilloscope Coupling AC: 720mV

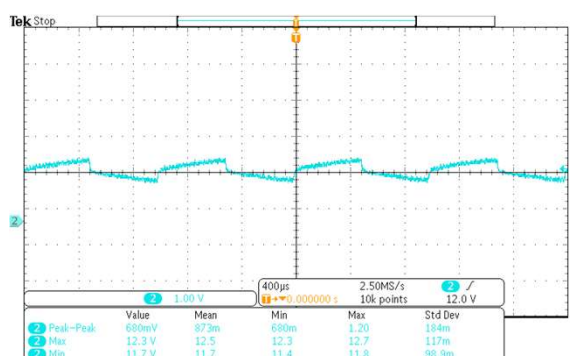

264Vac Oscilloscope Coupling AC: 680mV



环球半导体
Global Semiconductor

深圳市福田区上梅林中康路奥士达大厦A座312-316室
ADD: Scotia Centre, 4th Floor, P. O. Box 2840, Geogee Twon, Grand Cayman KY1-1112, Cayman Islands
TEL: 86 0755-82662217 82662215 FAX: 86 0755-82668680

电源在@90V和264V输入时的上升时间和过冲

11.9 Rise Time and Output Overshoot Waveform(上升时间和输出过冲)

测试条件:

- 1.. AC Input: 90V/60Hz, 230V/50Hz, 264V/50Hz
- 2.. Output Load: 12V3A
- 3.. Ta: 25°C
- 4.. Remark:

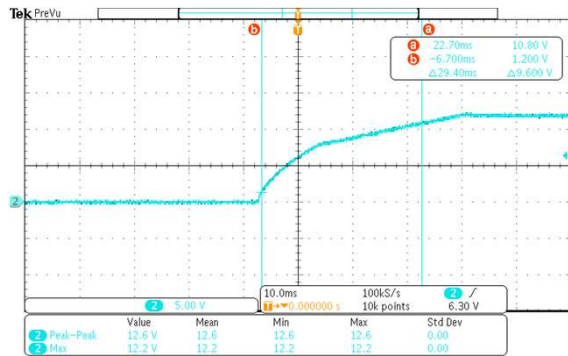

90Vac Rise Time: 29.4mS

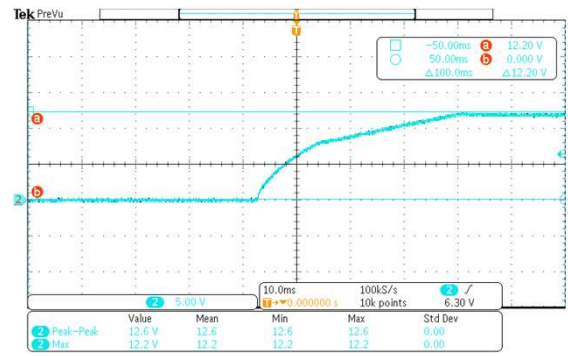

90Vac Full Load overshoot: 12.2V

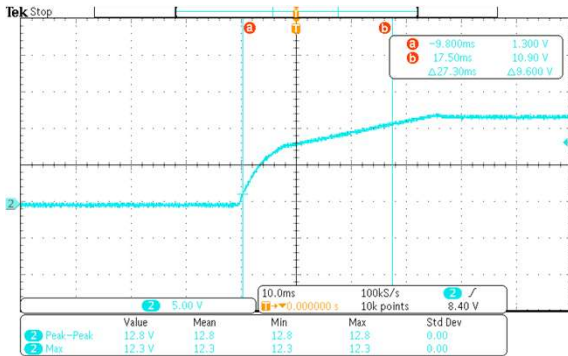

230Vac Rise Time: 27.3mS

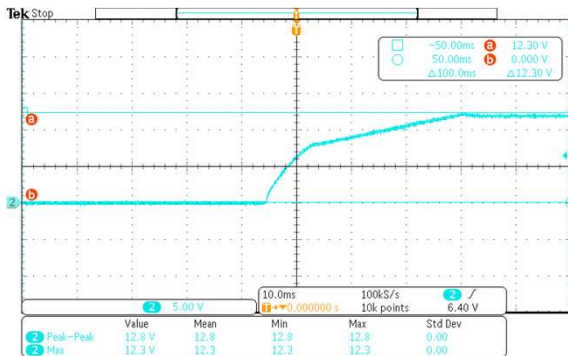

230Vac Full Load overshoot: 12.3V

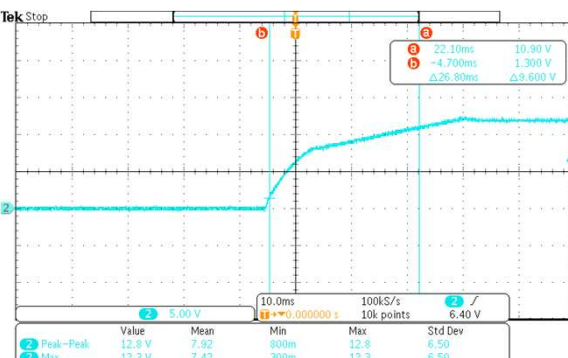

264Vac Rise Time: 26.8mS

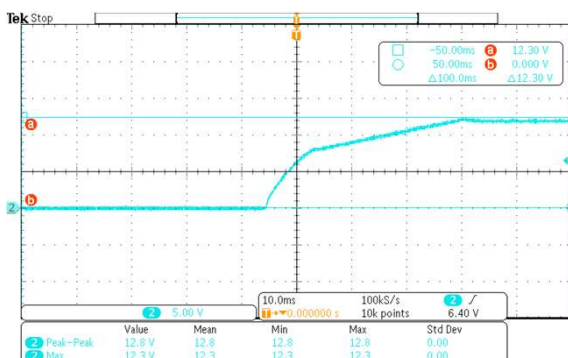

264Vac Full Load overshoot: 12.3V



深圳市福田区上梅林中康路奥士达大厦A座312-316室

ADD:Scotia Centre, 4th Floor, P. O. Box 2840, Geogee Twn, Grand Cayman KY1-1112, Cayman Islands

TEL: 86 0755-82662217 82662215 FAX: 86 0755-82668680

电源在 @120V和230V输入时的传导

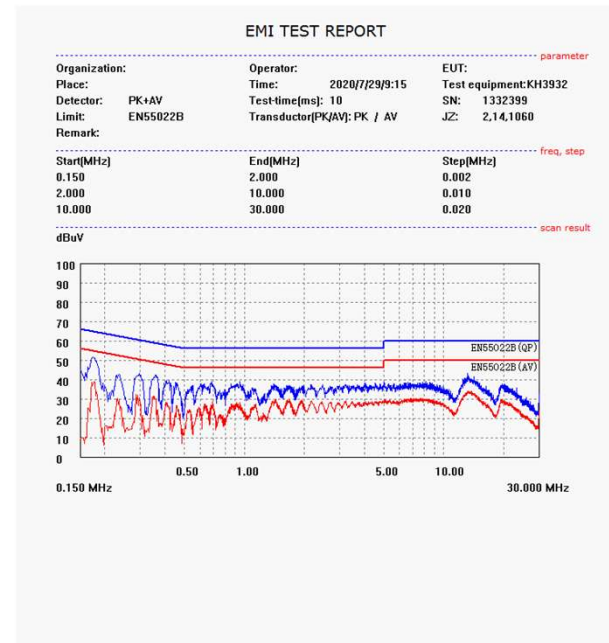
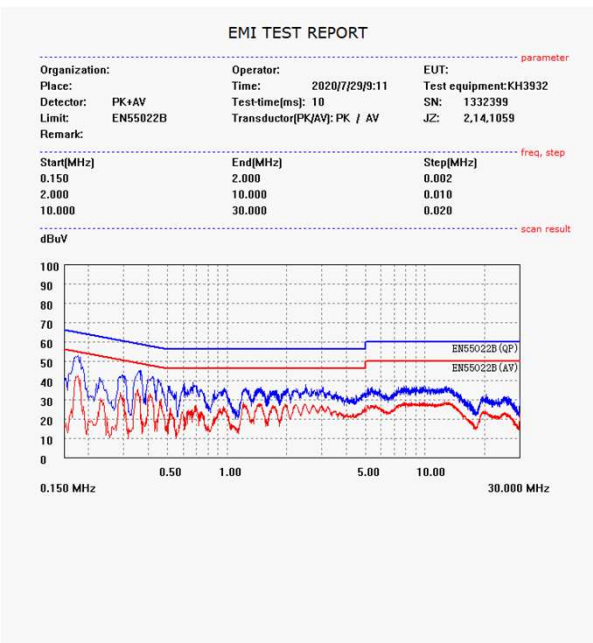
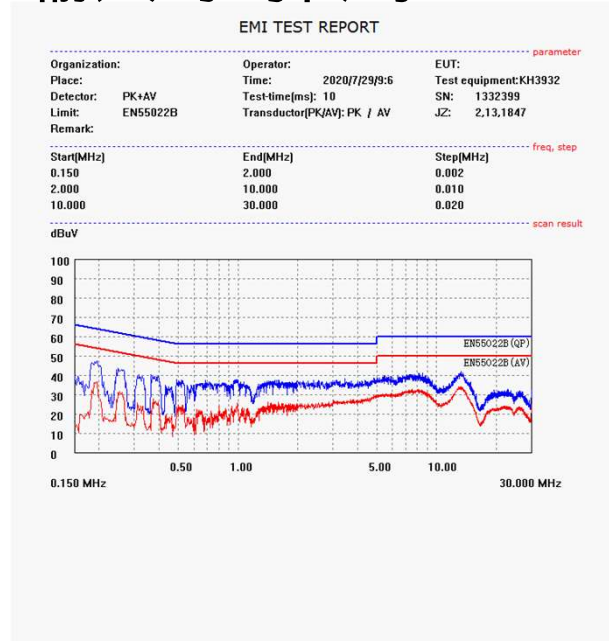
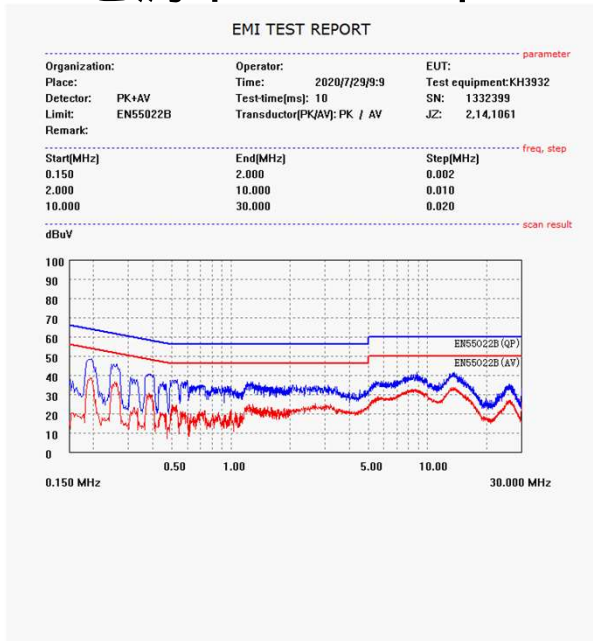

深圳市福田区上梅林中康路奥士达大厦A座312-316室
 ADD: Scotia Centre, 4th Floor, P. O. Box 2840, George Town, Grand Cayman KY1-1112, Cayman Islands
 TEL: 86 0755-82662217 82662215 FAX: 86 0755-82668680

电源在 @120V和230V输入时的辐射预估

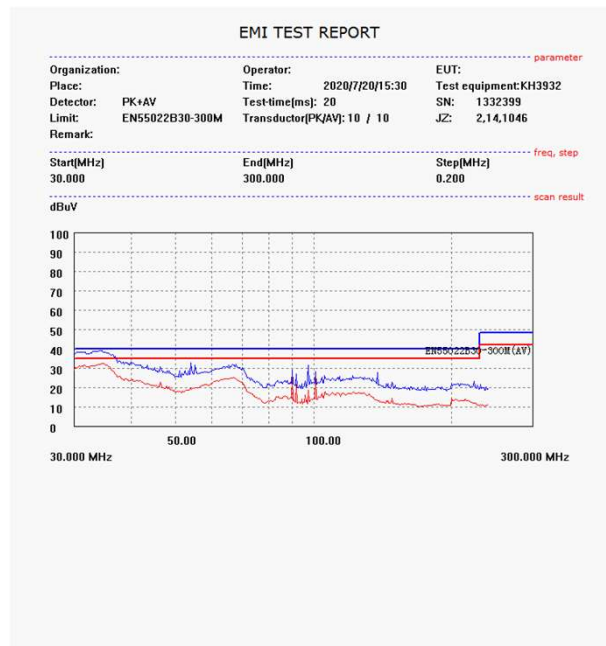
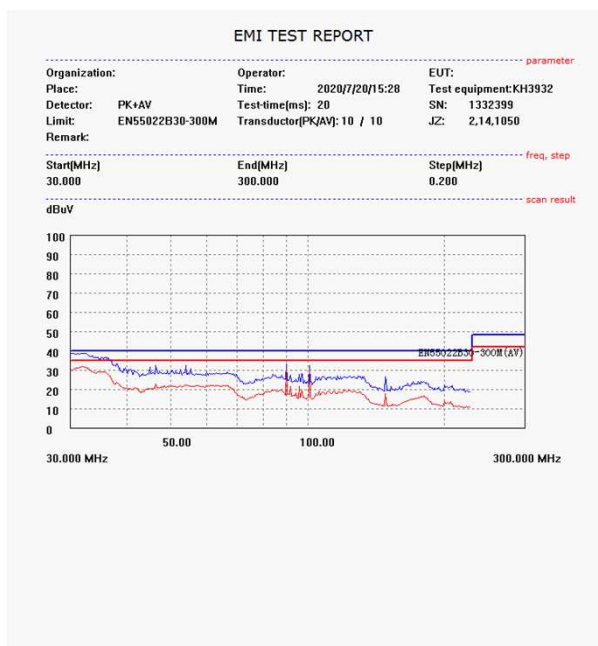
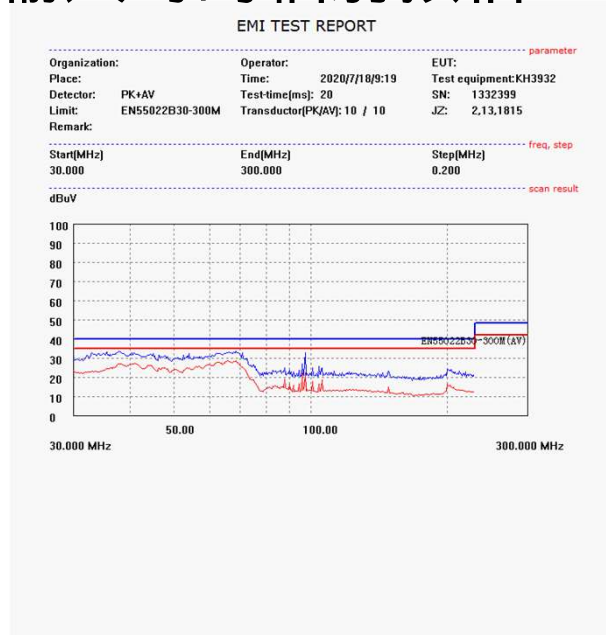
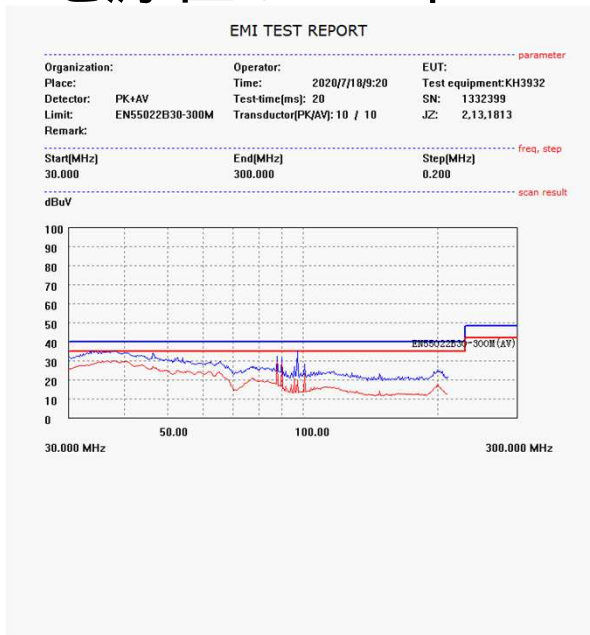

深圳市福田区上梅林中康路奥士达大厦A座312-316室
 ADD: Scotia Centre, 4th Floor, P. O. Box 2840, Geoge Twon, Grand Cayman KY1-1112, Cayman Islandgs
 TEL: 86 0755-82662217 82662215 FAX: 86 0755-82668680

变压器参数

12. Transformer specifications (变压器规格书)

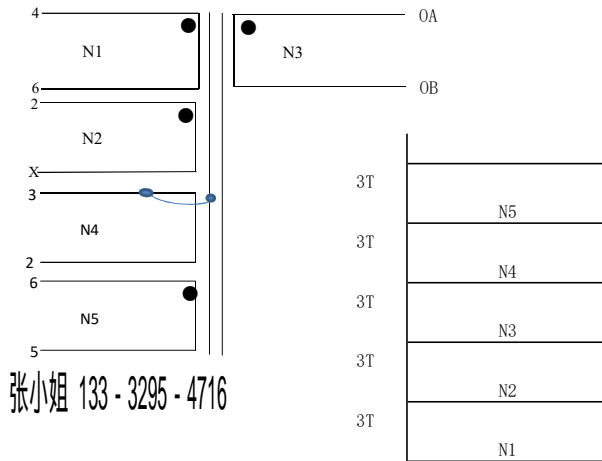

Note:
1. Dot (●) denote electrical start. (●定义为同名端)

张女士 133-3295-4716

| 序号 | 绕线参数(mm) | 圈数 | 胶带层数 | 起始脚 | 结束脚 | 挡墙胶带宽度(mm) | 套管 | | 备注 |
|----|---------------------|----|------|-----|-----|------------|-----|-----|------|
| | | | | | | | 起始脚 | 结束脚 | |
| N1 | 2UEW $\Phi 0.10*16$ | 30 | 3 | 4 | 6 | | | | 密绕二层 |
| N2 | 2UEW $\Phi 0.15*3$ | 5 | 3 | 2 | X | | | | 疏绕一层 |
| N3 | TEX $\Phi 0.60*2$ | 5 | 3 | OA | OB | | | | 密绕一层 |
| N4 | 2UEW $\Phi 0.15*3$ | 4 | 3 | 3 | 2 | | | | 疏绕一层 |
| N5 | 2UEW $\Phi 0.10*16$ | 15 | 3 | 6 | 5 | | | | 密绕一层 |

NOTE:

- Bobbin: RM10 槽宽10.5mm
- Core: RM10 (TDK PC95 or equivalent, $A_e: 90\text{mm}^2$)
- Lp1-3: 800uH @10KHz, 0.25V
- Part NO.:
- 膠帶材質: 3M1298或同等材質。
- Pin2用 $\Phi 0.15*3$ 线连接到磁芯上, 并接触良好。
- 绕制变压器时, 骨架初级Pin脚朝外顺时针绕制。
- 产品需真空含浸。
- N3用的三层绝缘线需加套管。

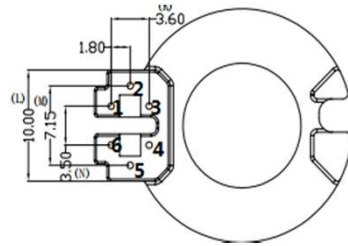

深圳市福田区上梅林中康路奥士达大厦A座312-316室
ADD: Scotia Centre, 4th Floor, P. O. Box 2840, George Town, Grand Cayman KY1-1112, Cayman Islands
TEL: 86 0755-82662217 82662215 FAX: 86 0755-82668680