

Transformer Driver for Isolated Power Supplies

FEATURES

- Push-Pull Driver for Small Transformers
- Single 3.3 V or 5 V Supply
- High Primary-side Current Drive:
 - 5 V Supply: 350 mA (max)
 - 3.3 V Supply: 150 mA (max)
- Low Ripple on Rectified Output Permits Small Output Capacitors
- Small 5-pin SOT23 Package

APPLICATIONS

- Isolated Interface Power Supply for CAN, RS-485, RS-422, RS-232, SPI, I2C, Low-Power LAN
- Industrial Automation
- Process Control
- Medical Equipment

DESCRIPTION

The ZCC6501 is a monolithic oscillator/power-driver, specifically designed for small form factor, isolated power supplies in isolated interface applications. It drives a low-profile, center-tapped transformer primary from a 3.3 V or 5 V DC power supply. The secondary can be wound to provide any isolated voltage based on transformer turns ratio.

The ZCC6501 consists of an oscillator followed by a gate drive circuit that provides the complementary output signals to drive the ground referenced N-channel power switches. The internal logic ensures break-before-make action between the two switches.

The ZCC6501 is available in a small SOT23-5 package, and is specified for operation at temperatures from -40°C to 125°C .

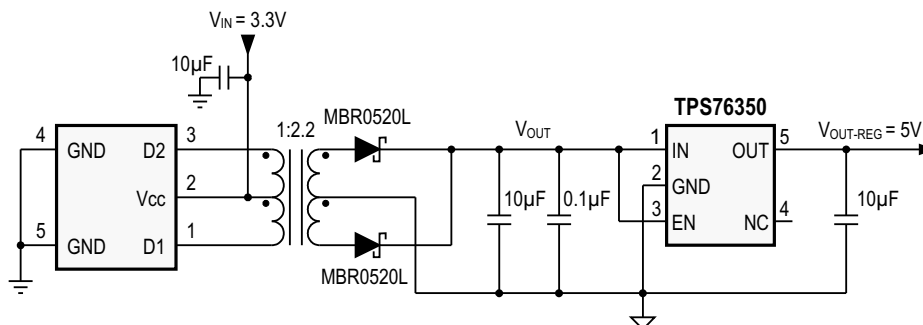
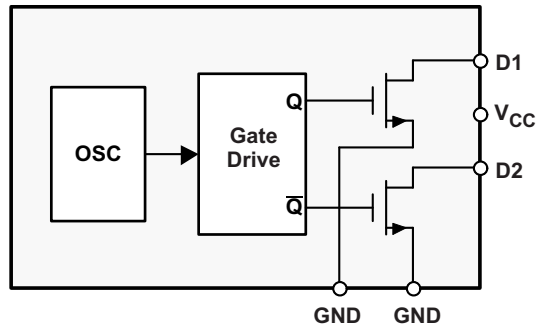

Figure 1. Typical Operating Circuit



These devices have limited built-in ESD protection. The leads should be shorted together or the device placed in conductive foam during storage or handling to prevent electrostatic damage to the MOS gates.

FUNCTIONAL BLOCK DIAGRAM



PIN FUNCTIONS

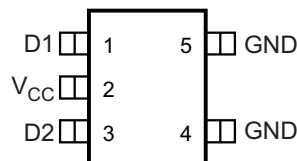

PIN No.	NAME	DESCRIPTION
1	D1	Drain 1
2	Vcc	Supply voltage
3	D2	Drain 2
4,5	GND	Ground

TEST CIRCUIT

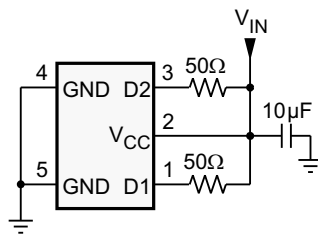

Figure 2. Test Circuit for R_{ON} , f_{OSC} , f_{St} , t_{r-D} , t_{f-D} , t_{BBM}

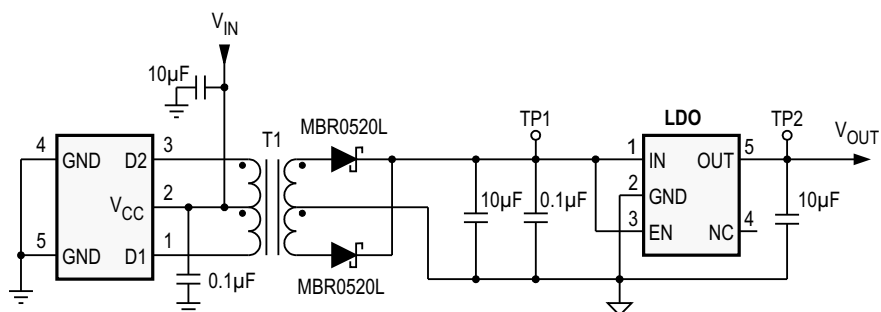

Figure 3. Test Circuit for Output Voltage and Efficiency at TP1 and TP2

ABSOLUTE MAXIMUM RATINGS

over operating free-air temperature range (unless otherwise noted) ⁽¹⁾

			VALUES	
V _{CC}	Supply voltage		-0.3 V to +6 V	
V _{D1} , V _{D2}	Output switch voltage		14 V	
I _{D1P} , I _{D2P}	Peak output switch current		500 mA	
P _{TOT}	Continuous power dissipation		250 mW	
ESD	Human Body Model	ESDA/JEDEC JS-001-2012	All Pins	±4 kV
	Charged Device Model	JEDEC JESD22-C101E		±1.5 kV
	Machine Model	JEDEC JESD22-A115-A		±200 V
T _{STG}	Storage temperature range		-65°C to 150°C	
T _J	Junction temperature		170°C	

(1) Stresses beyond those listed under ABSOLUTE MAXIMUM RATINGS cause permanent damage to the device. These are stress ratings only and functional operation of the device at these or any other conditions beyond those indicated under RECOMMENDED OPERATING CONDITIONS is not implied. Exposure to absolute-maximum-rated conditions for extended periods affects device reliability.

THERMAL INFORMATION

THERMAL METRIC ⁽¹⁾		ZCC6501	UNITS
		DBV 5-PINS	
θ _{JA}	Junction-to-ambient thermal resistance	208.3	°C/W
θ _{JCtop}	Junction-to-case (top) thermal resistance	87.1	
θ _{JB}	Junction-to-board thermal resistance	40.4	
ψ _{JT}	Junction-to-top characterization parameter	5.2	
ψ _{JB}	Junction-to-board characterization parameter	39.7	
θ _{JCbot}	Junction-to-case (bottom) thermal resistance	N/A	

(1) For more information about traditional and new thermal metrics, see the *IC Package Thermal Metrics* application report.

RECOMMENDED OPERATING CONDITIONS

			MIN	TYP	MAX	UNIT
V _{CC}	Supply voltage		3	5.5		V
V _{D1} , V _{D2}	Output switch voltage	V _{CC} = 5 V ± 10%,	0		11	V
		V _{CC} = 3.3 V ± 10%				
I _{D1} , I _{D2}	D1 and D2 output switch current – Primary-side	V _{CC} = 5 V ± 10%			350	mA
		V _{CC} = 3.3 V ± 10%				
T _A	Ambient temperature		-40	125		°C

ELECTRICAL CHARACTERISTICS

Over full-range of recommended operating conditions, unless otherwise noted

PARAMETER		TEST CONDITIONS	MIN	TYP	MAX	UNIT
R _{ON}	Switch-on resistance	V _{CC} = 3.3 V ± 10%, See Figure 2		1		Ω
		V _{CC} = 5.0 V ± 10%, See Figure 2		0.6		
I _{CC}	Average supply current ⁽¹⁾	V _{CC} = 3.3 V ± 10%, no load		300		uA
		V _{CC} = 5.0 V ± 10%, no load		500		
f _{ST}	Startup frequency	V _{CC} = 2.4 V, See Figure 2		230		kHz
f _{OSC}	Oscillator frequency	V _{CC} = 3.3 V ± 10%, See Figure 2		270		kHz
		V _{CC} = 5.0 V ± 10%, See Figure 2		300		
t _{r-D}	D1, D2 output rise time	V _{CC} = 3.3 V ± 10%, See Figure 2		400		ns
		V _{CC} = 5.0 V ± 10%, See Figure 2		500		
t _{f-D}	D1, D2 output fall time	V _{CC} = 3.3 V ± 10%, See Figure 2		180		ns
		V _{CC} = 5.0 V ± 10%, See Figure 2		100		
t _{BBM}	Break-before-make time	V _{CC} = 3.3 V ± 10%, See Figure 2		600		ns
		V _{CC} = 5.0 V ± 10%, See Figure 2		800		

(1) Average supply current is the current used by ZCC6501 only. It does not include load current.

DBV (R-PDSO-G5)

PLASTIC SMALL-OUTLINE PACKAGE

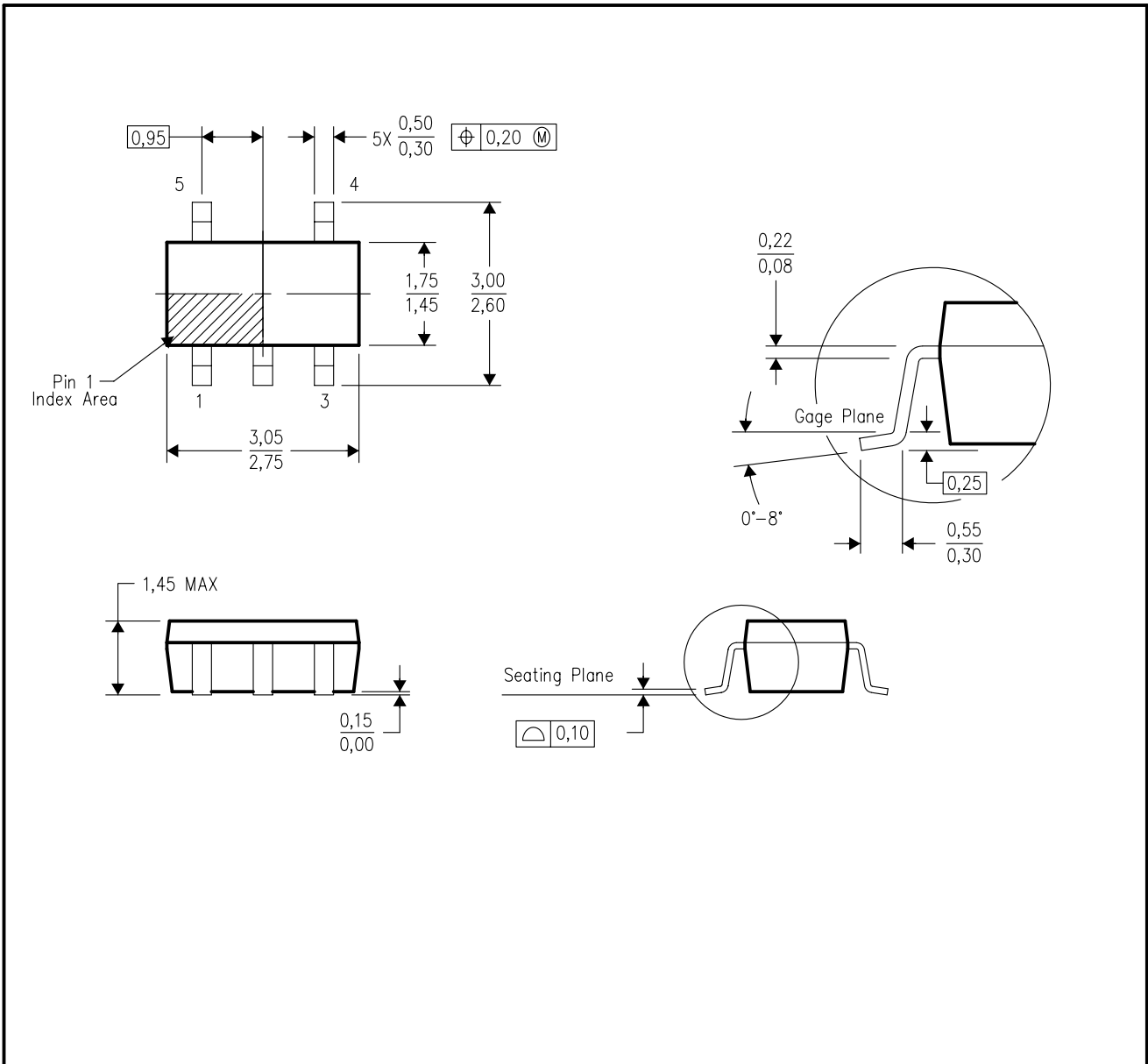

- NOTES:
- A. All linear dimensions are in millimeters.
 - B. This drawing is subject to change without notice.
 - C. Body dimensions do not include mold flash or protrusion. Mold flash and protrusion shall not exceed 0.15 per side.
 - D. Falls within JEDEC MO-178 Variation AA.