

## 28V High Efficiency 1MHz, 2A Step Up Regulator

### FEATURES

- Integrated 80mΩ Power MOSFET
- 2V to 24V Input Voltage
- 1MHz Fixed Switching Frequency
- Internal 4A Switch Current Limit
- Adjustable Output Voltage
- Internal Compensation
- Up to 28V Output Voltage
- Automatic Pulse Frequency Modulation
- Mode at Light Loads
- up to 97% Efficiency
- Available in a 6-Pin SOT23-6 Package

### APPLICATIONS

- Battery-Powered Equipment
- Set-Top Boxes
- White LED Driver
- DSL and Cable Modems and Routers
- Networking cards powered from PCI or PCI express slots

### GENERAL DESCRIPTION

The IA1312 is a constant frequency, 6-pin SOT23 current mode step-up converter intended for small, low power applications. The IA1312 switches at 1MHz and allows the use of tiny, low cost capacitors and inductors 2mm or less in height. Internal soft-start results in small inrush current and extends battery life. The IA1312 features automatic shifting to pulse frequency modulation mode at light loads. The IA1312 includes under-voltage lockout, current limiting, and thermal overload protection to prevent damage in the event of an output overload. The IA1312 is available in a small 6-pin SOT-23 package.

### TYPICAL APPLICATION

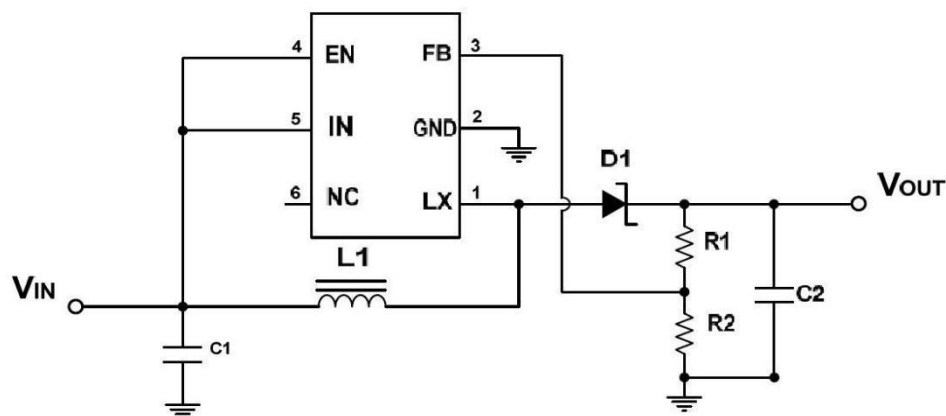
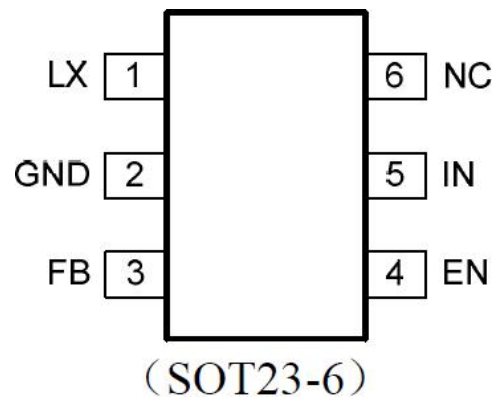

Figure1. Basic Application Circuit

## ABSOLUTE MAXIMUM RATINGS

Parameter	Symbol	Conditions	Min.	Typ.	Max.	Unit
Supply Voltage	Vcc		2		24	V
LX Voltage	VLX				28	V
EN,FB Voltage	V				24	V
Junction Temperature					155	°C
Operating Temperature			-40		+85	°C
Lead Temperature					300	°C
Power Dissipation	PD				500	mW

## PACKAGE & PIN DESCRIPTION



PIN	NAME	FUNCTION
1	LX	Power Switch Output. LX is the drain of the internal MOSFET switch. Connect the power inductor and output rectifier to LX. LX can swing between GND and 28V.
2	GND	Ground Pin
3	FB	Feedback Input. The FB voltage is 0.6V. Connect a resistor divider to FB.
4	EN	Regulator On/Off Control Input. A high input at EN turns on the converter, and a low input turns it off. When not used, connect EN to the input supply for automatic startup.
5	IN	Input Supply Pin. Must be locally bypassed.
6	NC	Not Connection

## ELECTRICAL CHARACTERISTICS

( $V_{IN}=V_{EN}=5V$ ,  $T_A = 25^{\circ}C$ , unless otherwise noted.)

Parameter	Conditions	MIN	TYP	MAX	unit
Operating Input Voltage		2		24	V
Under Voltage Lockout				1.98	V
Under Voltage Lockout Hysteresis			100		mV
Current (Shutdown)	$V_{EN} = 0V$		0.1	1	$\mu A$
Quiescent Current (PFM)	$V_{FB}=0.7V$ , No switch		100	200	$\mu A$
Quiescent Current (PWM)	$V_{FB}=0.5V$ , switch		1.6	2.2	mA
Switching Frequency			1		MHz
Maximum Duty Cycle	$V_{FB} = 0V$	90			%
EN Input High Voltage		1.5			V
EN Input Low Voltage				0.4	V
FB Voltage		0.588	0.6	0.612	V
FB Input Bias Current	$V_{FB} = 0.6V$	-50	-10		nA
LX On Resistance (1)			80		m $\Omega$
LX Current Limit (1)	$V_{IN}= 5V$ , Duty cycle=50%		3.5		A
LX Leakage	$V_{LX} = 20V$			1	$\mu A$
Thermal Shutdown			155		$^{\circ}C$

**Note:**

1) Guaranteed by design, not tested.

## OPERATION

The IA1312 uses a fixed frequency, peak current mode boost regulator architecture to regulate voltage at the feedback pin. The operation of the IA1312 can be understood by referring to the block diagram of Figure 3. At the start of each oscillator cycle the MOSFET is turned on through the control circuitry. To prevent sub-harmonic oscillations at duty cycles greater than 50 percent, a stabilizing ramp is added to the output of the current sense amplifier and the result is fed into the negative input of the PWM comparator. When this voltage equals the output voltage of the error amplifier the power MOSFET is

turned off. The voltage at the output of the error amplifier is an amplified version of the difference between the 0.6V band gap reference voltage and the feedback voltage. In this way the peak current level keeps the output in regulation. If the feedback voltage starts to drop, the output of the error amplifier increases. These results in more current to flow through the power MOSFET, thus increasing the power delivered to the output. The IA1312 has internal soft start to limit the amount of input current at startup and to also limit the amount of overshoot on the output.

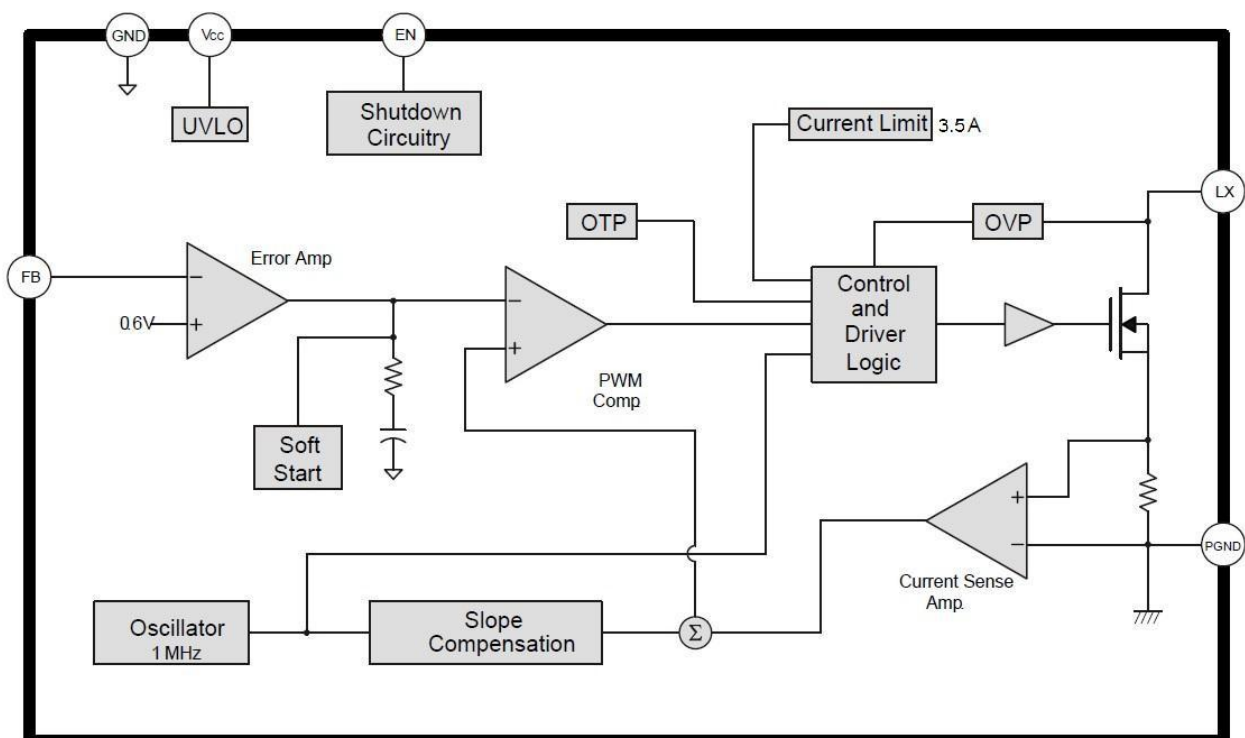

Figure 3. Functional Block Diagram

## APPLICATION INFORMATION

### Setting the Output Voltage

The internal reference VREF is 0.6V (Typical).The output voltage is divided by a resistor divider,R1 and R2 to the FB pin. The output voltage is given by

$$V_{OUT} = V_{REF} \times \left(1 + \frac{R_1}{R_2}\right)$$

### Inductor Selection

The recommended values of inductor are 4.7 to 22μH. Small size and better efficiency are the major concerns for portable device, such as IA1312 used for mobile phone. The inductor should have low core loss at 1MHz and low DCR for better efficiency. To avoid inductor saturation current rating should be considered.

### Capacitor Selection

Input and output ceramic capacitors of 22μF are recommended for IA1312 applications. For better voltage filtering, ceramic capacitors with low ESR are recommended. X5R and X7R types are suitable because of their wider voltage and temperature ranges.

### Diode Selection

Schottky diode is a good choice for IA1312 because of its low forward voltage drop and fast reverses recovery. Using Schottky diode can get better efficiency. The high speed rectification is also a good characteristic of Schottky diode for high switching frequency. Current rating of the diode must meet the root mean square of the peak current and output average current multiplication as following :

$$I_D (RMS) \approx \sqrt{I_{OUT} \times I_{PEAK}}$$

The diode' s reverse breakdown voltage should be larger than the output voltage.

### Layout Consideration

For best performance of the IA1312, the following guidelines must be strictly followed.

- Input and Output capacitors should be placed close to the IC and connected to ground plane to reduce noise coupling.
- The GND should be connected to a strong ground plane for heat sinking and noise protection.
- Keep the main current traces as possible as short and wide.
- LX node of DC-DC converter is with high frequency voltage swing. It should be kept at a small area.
- Place the feedback components as close as possible to the IC and keep away from the noisy devices.

PACKAGE INFORMATION

SOT23-6

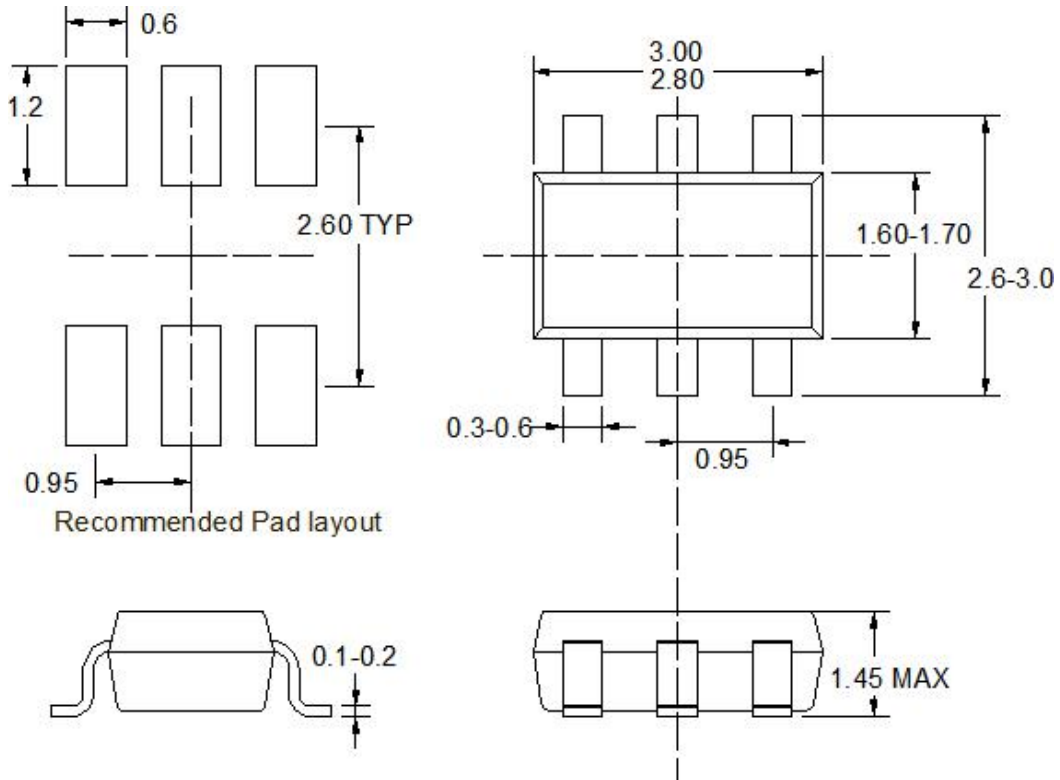

Notes: All dimensions are in millimeters.  
All dimensions don't include mold flash & metal burr.