

GENERAL DESCRIPTION

OB2222LM is a high performance, high precision and low cost PWM Power switch for non-isolated buck and buck-boost application. It combines a dedicated current mode PWM controller with a high voltage power Bipolar in SOP8 package. Its built-in error amplifier is optimized for good overshoot and dynamic response for low cost and component count. With precise inner resistor divider, precise reference of EA, constant voltage regulation of 5.0V at universal AC input can be guaranteed. Frequency reduction and burst mode control is implemented for high efficiency at light load. Good EMI performance is achieved with On-Bright proprietary frequency shuffling technique and soft base driver design. Low startup current and low operating current contribute to a reliable power on startup and low standby power consumption with OB2222LM. Constant power operation is supported at over load application with OB2222LM, which makes it suitable for small home appliance application where instant large power consumption is required such as start-up of a fan.

OB2222LM offers power on soft start control and protection coverage with auto-recovery features including cycle-by-cycle current limiting, output short circuit protection, FB pin open loop protection, on-chip Over Temperature Protection (OTP), VDD Over Voltage Protection (OVP), Over Loading Protection (OLP) and VDD Under Voltage Lockout Protection (UVLO).

The tone energy at below 20KHz is minimized in the design so that audio noise is eliminated during operation.

OB2222LM is offered in SOP8 package.

TYPICAL APPLICATION

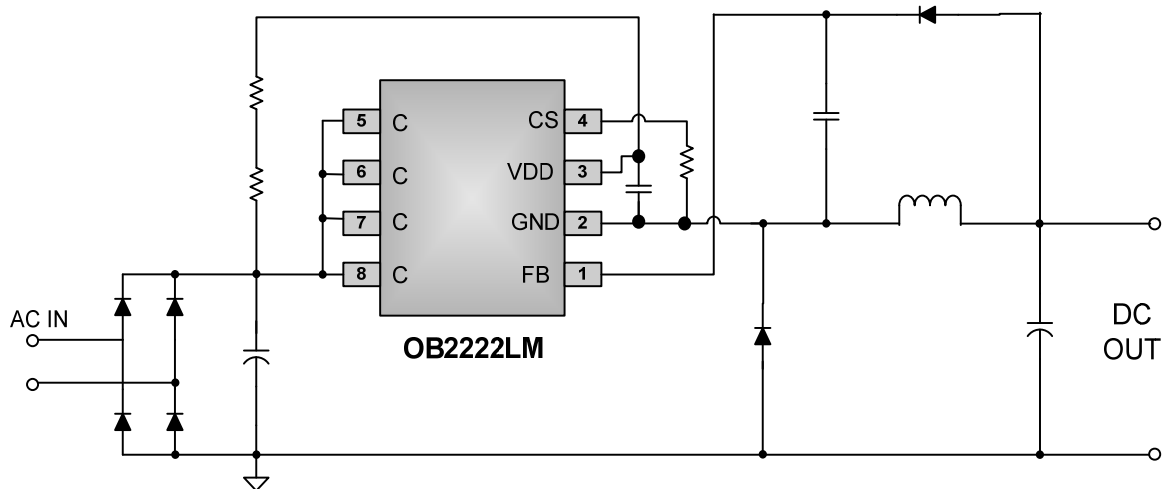

FEATURES

- Universal AC input range and 5.0V output voltage
- Peak load operation with increased frequency
- Low cost and less BOM for buck and buck-boost applications
- Current mode control
- 40kHz (typical) normal switching frequency
- Frequency-reduction and burst mode control for high efficiency
- Frequency shuffling for EMI improvement
- Power on soft-start
- Built-in Leading Edge Blanking (LEB)
- Cycle-by-cycle current limiting
- FB pin open loop protection
- Output short-circuit protection
- VDD Under Voltage Lockout with Hysteresis
- VDD OVP
- Over Loading Protection
- On-Chip OTP

APPLICATIONS

Low power AC/DC offline SMPS for

- Small home appliance
- Linear regulator/RCC replacement

GENERAL INFORMATION

Pin Configuration

The pin map is shown as below for SOP8

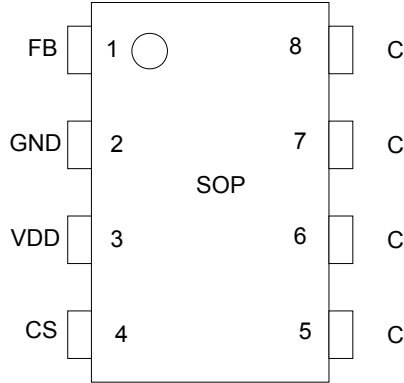

Ordering Information

Part Number	Description
OB2222LMCP	SOP8, Pb-free, Tube
OB2222LMCPA	SOP8, Pb-free, T&R

Package Dissipation Rating

Package	R θ JA (°C/W)
SOP8	90

Note: Drain Pin Connected 100mm² PCB copper clad.

Output Power Table

Topology	90~264Vac Input (open frame)
Buck/Buck-Boost	350mA

Note: Maximum continuous power with drain pattern connected 100mm² PCB copper clad, at 50°C ambient.

Topology	90~264Vac Input (open frame)
Buck/Buck-Boost	300mA

Note: Maximum continuous power with drain pattern connected 100mm² PCB copper clad, at 85°C ambient.

Absolute Maximum Ratings

Parameter	Value
C-B Voltage	700V
VDD Voltage	-0.3 to 20V
FB Voltage	-0.3 to 20V
CS Input Voltage	-0.3 to 7V
Min/Max Operating Junction Temperature T _J	-40 to 150 °C
Operating Ambient Temperature T _A	-40 to 85 °C
Min/Max Storage Temperature T _{stg}	-55 to 150 °C
Lead Temperature (Soldering, 10secs)	260 °C

Note: Stresses beyond those listed under “absolute maximum ratings” may cause permanent damage to the device. These are stress ratings only, functional operation of the device at these or any other conditions beyond those indicated under “recommended operating conditions” is not implied. Exposure to absolute maximum-rated conditions for extended periods may affect device reliability.

Recommended Operating Condition

Symbol	Parameter	Range
VDD	VDD Supply Voltage	4.5 to 6V

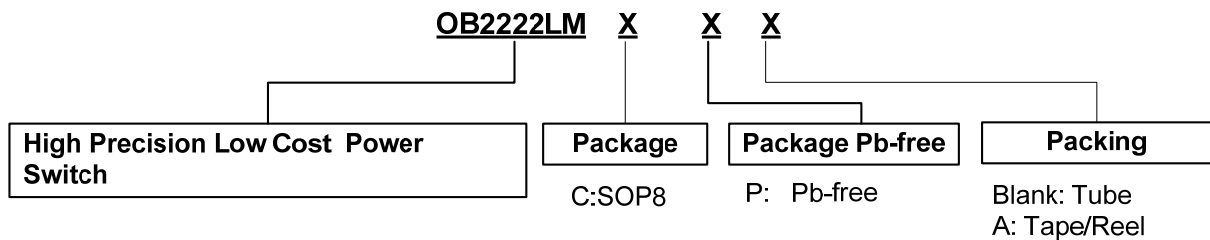

Marking Information

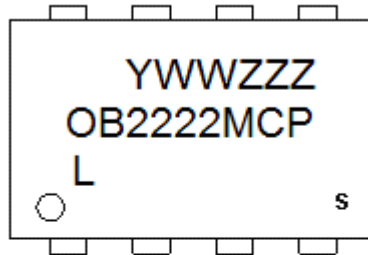

Y: Year Code
 WW: Week Code(01-52)
 ZZZ:Lot Code
 C:SOP8 Package
 P:Pb-free Package
 L:Character Code
 S:Internal Code(Optional)

TERMINAL ASSIGNMENTS

Pin Num	Pin Name	I/O	Description
1	FB	I	Output Voltage Feedback. This pin should connect a capacitor to ground.
2	GND	P	Ground
3	VDD	P	Power Supply
4	CS	I	Current sense input
5/6/7/8	C	O	Power bipolar collector pins.

BLOCK DIAGRAM

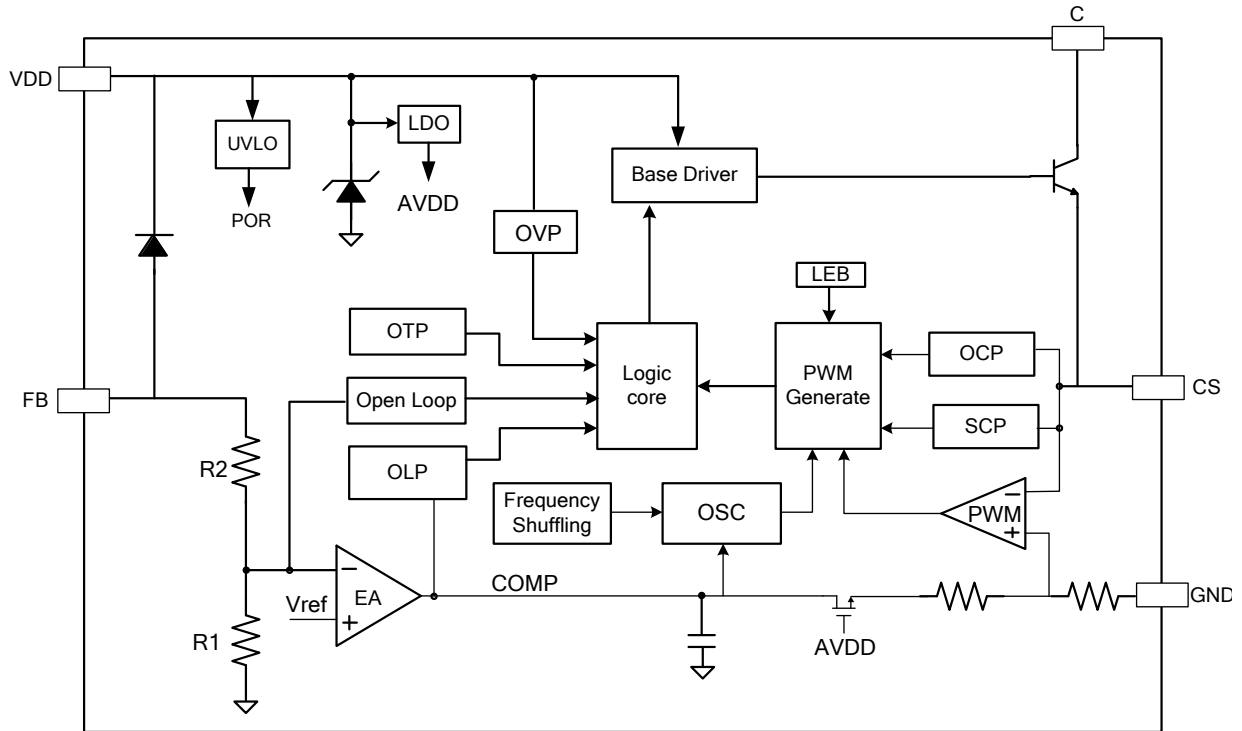

ELECTRICAL CHARACTERISTICS

(T_A = 25°C, VDD=5.5V, if not otherwise noted)

Symbol	Parameter	Test Conditions	Min	Typ.	Max	Unit
Supply Voltage (VDD) Section						
I _{startup}	Startup Current	VDD=UVLO(off) -1V			10	uA
I _{VDD_op}	Operation Current	Operation supply current CS=0.5V		1.5	2.5	mA
		Operation supply current FB=6V		0.6		mA
UVLO(ON)	VDD Under Voltage Lockout Enter	VDD falling, gate disappear	3	3.7	3.9	V
UVLO(OFF)	VDD Under Voltage Lockout Exit	VDD rising	10.5	11.5	12.5	V
OVP	Over voltage protection Threshold	Ramp VDD until gate shut down	14	15	16	V
FB Regulation Voltage	In normal regulation, FB will be regulated to average of 5.15V			5.15		V
Current Sense Input Section						
TLEB	LEB time		250	300	350	ns
Vth_oc	Over current detection Threshold voltage		475	500	525	mV
Td_oc	OCP propagation delay			50	100	ns
Vth_scp	Short Current protection threshold voltage		0.6	0.7	0.8	V
Vth_fit	CS floating protection threshold voltage		0.9	1.0	1.1	V
EA Section						
Vref	EA reference		1.44	1.5	1.56	V
Kfb/vref	FB divider coefficient			3.43		
Frequency Section						
Freq_nor	Normal operation frequency		36	40	44	KHz
Freq_pk	IC Maximum frequency			65		KHz
Δf/Freq	Frequency shuffling range			+/-8		%
F_shuffling	Shuffling frequency			78		Hz
Dmax	Maximum Duty Cycle		7	11	15	%
F_Burst	Burst Mode Switch Frequency			20		KHz
Base Driver Section						
Is_max	Base sourcing maximum current			90		mA
Is_preoff	Base sourcing current after pre-off			3		mA
Protection Section						
Vth_OLP	FB pin open loop detection threshold voltage			0.515		V
Td_OLP	Over Load protection debounce time			10		mS
OTP	Power switch temperature for exiting over temperature protection			125		°C
	Power switch temperature for entering over temperature protection			150		°C
Power BJT Section						
Vceo	Collector-emitter breakdown voltage	Ic=10mA, Ib=0	450			V
Vcbo	Collector-base breakdown voltage	Ic=10mA	700			V
Ic	Collect Peak Current			1.5		A

CHARACTERIZATION PLOTS

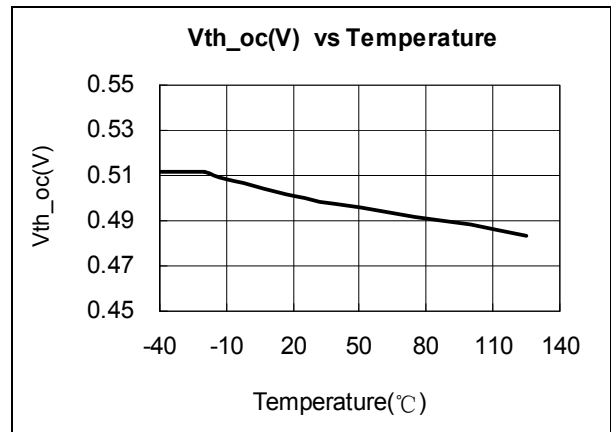
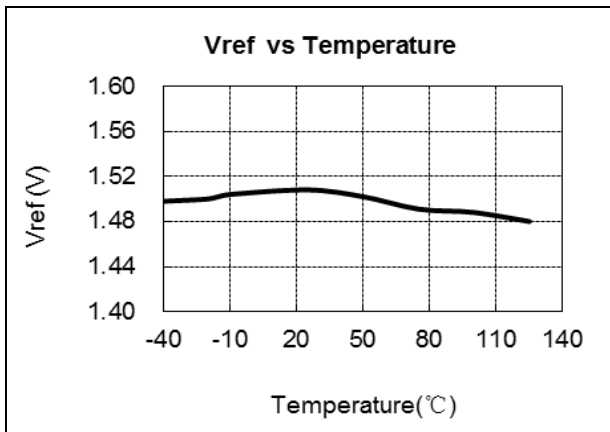
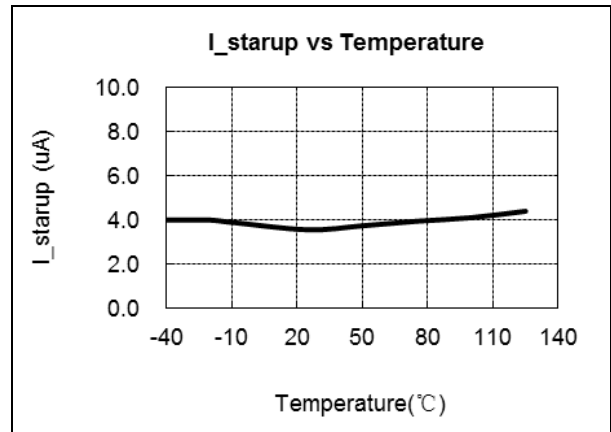
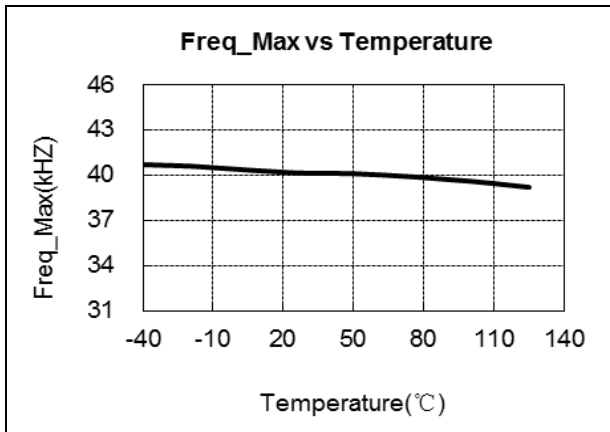
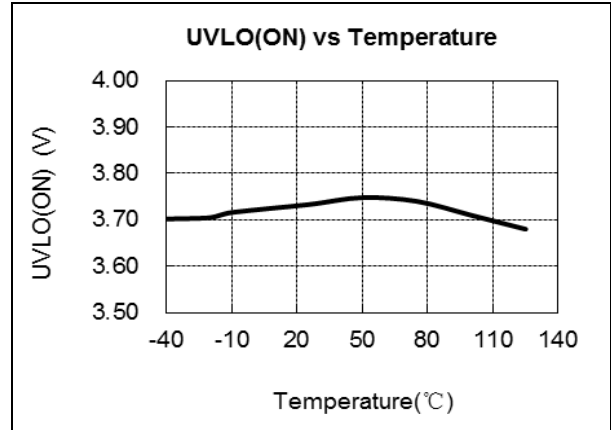
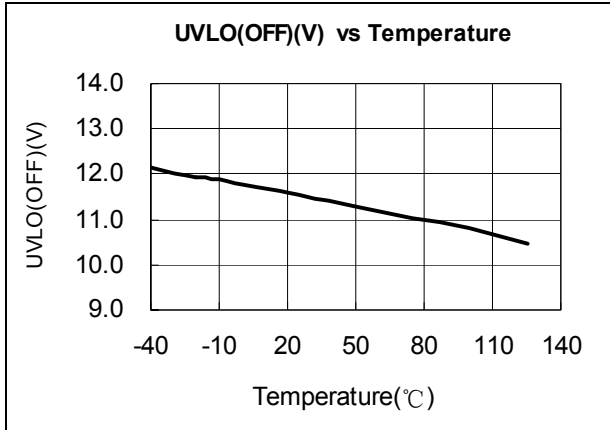

OPERATION DESCRIPTION

OB2222LM is a cost effective PWM power switch optimized for off-line non-isolated buck or buck-boost applications for small home appliances and linear regulator replacement. It operates in current mode and regulates output voltage with dedicated features. High integration can afford low cost and component count solution.

Startup Current and Start up Control

Startup current of OB2222LM is designed to be very low so that VDD could be charged up above UVLO threshold and starts up quickly. A large value startup resistor can therefore be used to minimize the power loss in application.

Operating Current

The Operating current of OB2222LM is as low as 1.5mA (typical). Good efficiency is achieved with the low operation current together with 'Multi-mode' control features.

PWM operation

The normal switching frequency of OB2222LM is internally fixed at 40kHz (typical). No external frequency setting components are required for PCB design simplification. Along with the increase of output current, the inductance current is up to the V_{th_oc} threshold. With the increase in output current, the operation frequency increases till it reaches the up limit of 65kHz (typical). The over load protection will be triggered after 10ms (typical).

At light load or zero load condition, most of the power dissipation in a switching mode power supply is from switching loss on the BJT. The magnitude of power loss is in proportion to the switching frequency. Lower switching frequency leads to the reduction on the power loss and thus conserves the energy. The frequency reduction and burst mode operation are implemented to achieve high efficiency at light load. The minimum switching frequency is 20kHz (typical).

Frequency shuffling for EMI improvement

The frequency shuffling (switching frequency modulation) is implemented in OB2222LM. The oscillation frequency is modulated so that the tone energy is spread out. The spread spectrum minimizes the conduction band EMI and therefore eases the system design.

Soft Start

OB2222LM features an internal 256 cycles (typical) soft start to soften the electrical stress occurring in the power supply during startup. It is activated during the power on sequence. After VDD reaches UVLO(OFF), the switching frequency is gradually increased from 10kHz to 40kHz. Every restart up is followed by a soft start.

Current Sensing and Leading Edge Blanking

Cycle-by-Cycle current limiting is offered in OB2222LM current mode PWM control. The switch current is detected by a sense resistor into the CS pin. An internal leading edge blanking circuit chops off the sensed voltage spike at initial internal BJT on state so that the external RC filtering on sense input is no longer needed. The PWM duty cycle is determined by the current sense input voltage and the EA output voltage.

Base Driver

The driver is a push pull stage with supply voltage VDD. It provides the driving current for the external power bipolar transistor. The sourcing current is limited to I_{s_max} (typical 90mA).

Protection Control

Good power supply system reliability is achieved with its rich protection features including cycle-by-cycle current limiting, output short circuit protection, FB pin open loop protection, on-chip Over Temperature Protection (OTP), VDD Over Voltage Protection (OVP), Over Loading Protection and VDD Under Voltage Lockout Protection (UVLO).

PACKAGE MECHANICAL DATA

SOP8 PACKAGE OUTLINE DIMENSIONS

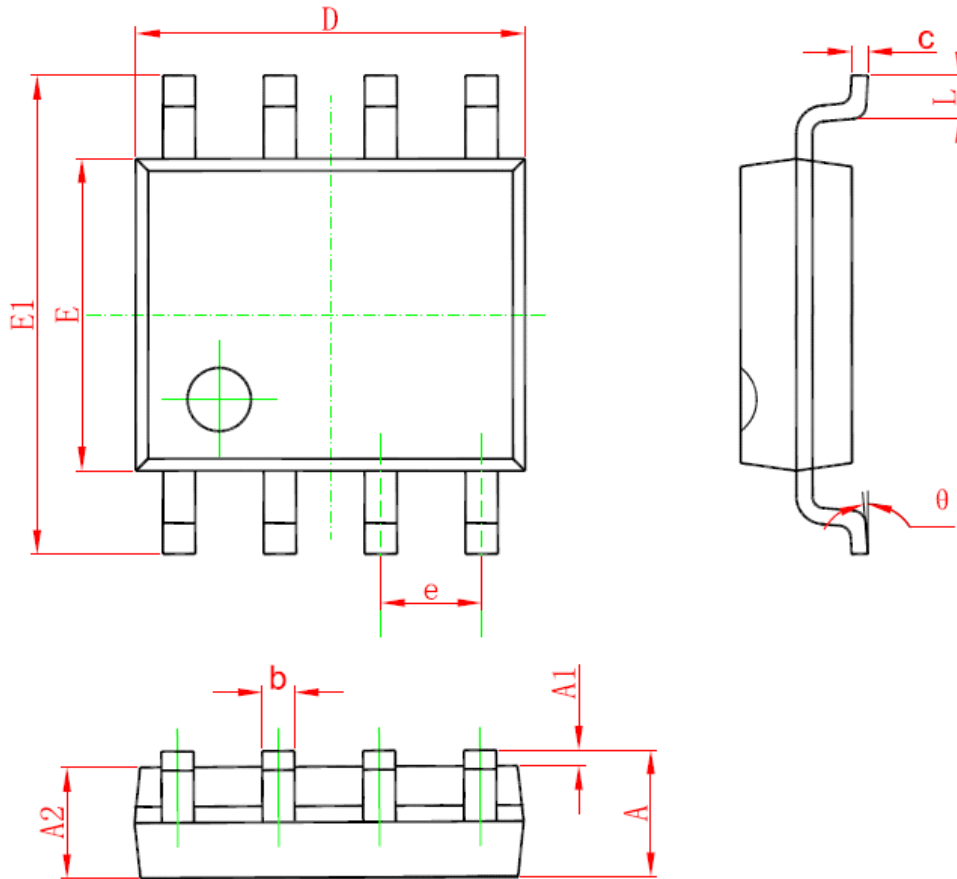

Symbol	Dimensions In Millimeters		Dimensions In Inches	
	Min	Max	Min	Min
A	1.350	1.750	0.053	0.069
A1	0.050	0.250	0.002	0.010
A2	1.250	1.650	0.049	0.065
b	0.310	0.510	0.012	0.020
c	0.170	0.250	0.006	0.010
D	4.700	5.150	0.185	0.203
E	3.800	4.000	0.150	0.157
E1	5.800	6.200	0.228	0.244
e	1.270 (BSC)		0.05 (BSC)	
L	0.400	1.270	0.016	0.050
θ	0°	8°	0°	8°

IMPORTANT NOTICE

RIGHT TO MAKE CHANGES

On-Bright Electronics Corp. reserves the right to make corrections, modifications, enhancements, improvements and other changes to its products and services at any time and to discontinue any product or service without notice. Customers should obtain the latest relevant information before placing orders and should verify that such information is current and complete.

WARRANTY INFORMATION

On-Bright Electronics Corp. warrants performance of its hardware products to the specifications applicable at the time of sale in accordance with its standard warranty. Testing and other quality control techniques are used to the extent it deems necessary to support this warranty. Except where mandated by government requirements, testing of all parameters of each product is not necessarily performed.

On-Bright Electronics Corp. assumes no liability for application assistance or customer product design. Customers are responsible for their products and applications using On-Bright's components, data sheet and application notes. To minimize the risks associated with customer products and applications, customers should provide adequate design and operating safeguards.

LIFE SUPPORT

On-Bright Electronics Corp.'s products are not designed to be used as components in devices intended to support or sustain human life. On-bright Electronics Corp. will not be held liable for any damages or claims resulting from the use of its products in medical applications.

MILITARY

On-Bright Electronics Corp.'s products are not designed for use in military applications. On-Bright Electronics Corp. will not be held liable for any damages or claims resulting from the use of its products in military applications.