

泰德半导体-提供样品, 技术支持 13418601901 QQ409545144

General Description

TD1736 is a DC/DC Buck Synchronous with four current limit pins suitable for many multi-output applications. It is designed to allow for operating a wide supply voltage range from 9V to 40V. It has both high-side and low-side drivers allowing synchronous configuration using two external power-NMOS. This IC can operate in both Constant Current (CC) and Constant Voltage (CV) modes.

TD1736 operates as a DC-DC Buck Controller providing a wide range of outputs at Constant Current (CV) from 1.2V to 28V and the output current as high as 10A or above. It has a Constant Current(CC) mode so that output current can be set externally and at a accuracy of +/-7%.

The current mode control and external compensation makes feedback control have good line and load regulation with flexible external design.

There are four independent current limit control pins for four separate loads. Each of the current limit can be set by a resistor(RCS) at 100mV across it. Of course, output peak current limit is working during normal operation

Pin Configurations

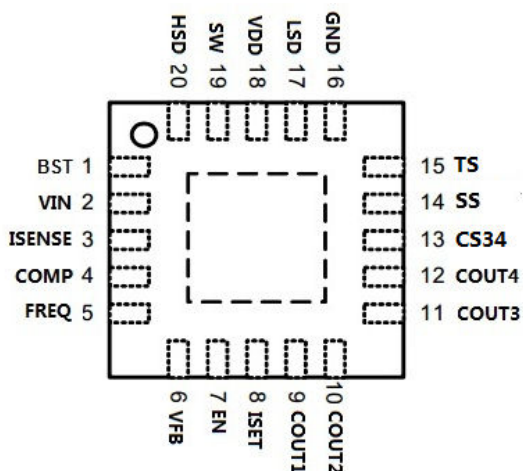

Figure1 Pin Configuration of TD1736(Top View)

Features

- Vin: 8.5V to 40V
- Vout: 1.2V to 28V; typical at 5V
- CC/CV Mode Control
- PFM Mode for Increased Light Load Efficiency
- 4 outputs current precision OCP: Adjustable Current-Limit Protection
- Burst mode when OCP/SCP occur
- Protection
 - NMOS peak current limit: accuracy: ~30%
 - Output short protection: reduce input current to less than 20mA(RMS)
 - Temperature shut down(OTP)
- Adjustable Output Cable Resistance Compensation
- Duty: 0~95%
- Switching Frequency: 100kHz to 300kHz
- Integrated MOSFET Drivers
- QFN20 Package

Applications

- Car Charger
- High-Brightness Lighting
- General-Purpose DC/DC Controller

Pin Description

Pin Number	Pin Name	Description
1	BST	Internal High Side Driver Power Bias which is typically 5V above Vin. A typical 0.1uF capacitor is used connecting between BST and SW pins
2	VIN	Supply input
3	ISENSE	Input Current Sense, the sense Resistor must be >5mohm
4	COMP	Error Amplifier Output and the Converter stability compensation network is placed
5	FREQ	Switching Frequency setting
6	FB	Feedback input with reference to 1.20V. it can sets output voltage
7	En	On/off control pin
8	ISET	To set output constant current
9	COU1	Current limit of the 1st output. The Threshold voltage is 108mV
10	COU2	Current limit of the 2nd output. The Threshold voltage is 108mV
11	COU3	Current limit of the 3rd output. The Threshold voltage is 108mV
12	COU4	Current limit of the 4th output. The Threshold voltage is 108mV
13	CS34	Pull low to disable COU3/COU4 CC function and high to enable
14	SS	Soft start pin. a capacitor is connected between this pin and GND
15	TS	Test pin
16	GND	Ground pin
17	LSD	Low Side Driver
18	VDD	Internal 5v power supply, a 1uF (or more) capacitor is connected between this pin and GND
19	SW	Inductor terminal
20	HSD	High Side Driver

Function Block

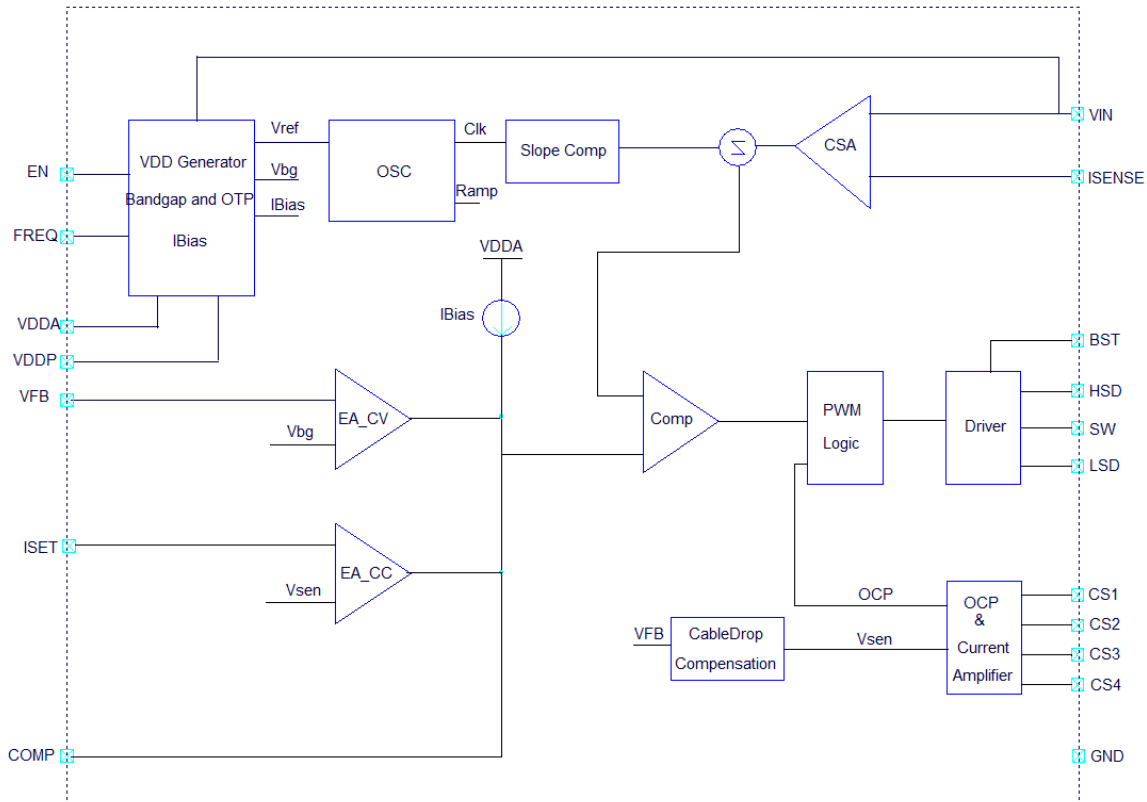

Figure 2 Function Block Diagram of TD1736

Absolute Maximum Ratings

Symbol	Parameter	Rating	Unit
VIN	Supply Input Voltage	-0.3 to +43	V
	ISNESE to VIN	-0.3 to +0.3	V
	BS to SW	-0.3 to +6	V
	SW to GND	-3 to VIN+1	V
	BS, HSD to GND	VSW-0.3 to VSW+6	V
	VFB,ISET,COMP,LSD, FREQ,SS CS34,TS to GND	-0.3 to +6	V
	COU1-4 to GND	-0.3 to +0.3	V
ESD	HBM (Human Body Mode)	2K	V
θ_{JA}	Thermal Resistance from Junction to ambient	40	°C/W

Recommended Operating Conditions

Symbol	Parameter	Rating			Unit
		Min.	Typ.	Max.	
VIN	Supply Voltage	9	-	40	V
VOUT	Output voltage range	1.2	-	28	V
IOUT	Output current range	-	-	20	A
	Operating Temperature	-40	-	85	°C
TSTG	Storage Temperature Range	-60	-	150	°C
TSDR	Maximum Lead Soldering Temperature, 10 Seconds	260			°C

Electrical Characteristics

(VIN=12V, TA=25°C (unless otherwise specified). MOSFET use TDM3436)

Symbol	Characteristic	Test conditions	Min	Typ	Max	Unit
VIN	Supply Voltage		9	-	40	V
IIN	Supply Input Current	EN=3V, Vout=5V, No load	0.5	1.5	3.0	mA
IQ	Shutdown Supply Current	EN=0	-	10	-	uA
VIN UVLO						
VUP	VIN UVLO Turn ON	VIN Rising	8.2	8.5	8.9	V
VHYS	VIN UVLO Hysteresis	VIN Falling	-	1.0	-	V
Feedback voltage						
VFB	Feedback voltage	VEN=3V	1.176	1.20	1.224	V
	Tolerance		-2	-	2	%
Oscillator						
Fsw	Switch frequency	R _{FREQ} =60Kohm	170	200	230	KHz
TON	Minimum On-Time		-	100	-	ns
D	Duty cycle		-	-	95	%
Current sense						
VTOCP	OCP threshold		100	108	116	mV
IFB	Cable compensation Current	Cout1-4=50mv	-	4.5	-	uA
HDR & LDR Drivers						
TRH	HDR Rising Time		-	10	-	ns
TFH	HDR Falling Time		-	10	-	ns
TRL	LDR Rising Time		-	10	-	ns
TFL	LDR Falling Time		-	10	-	ns
TLH	Dead Time		-	40	-	ns
THL	Dead Time		-	40	-	ns

40Vin 4 Outputs Buck Controller

TD1736

Soft start						
T _{SS}	Soft start time	CSS =0.1uF	-	10	-	ms
Thermal Shutdown(OTP)						
T _{SD}	Temperature Rising		-	140	-	°C
T _{HYS}	OTP Hysteresis		-	30	-	°C

Typical Application Circuit1

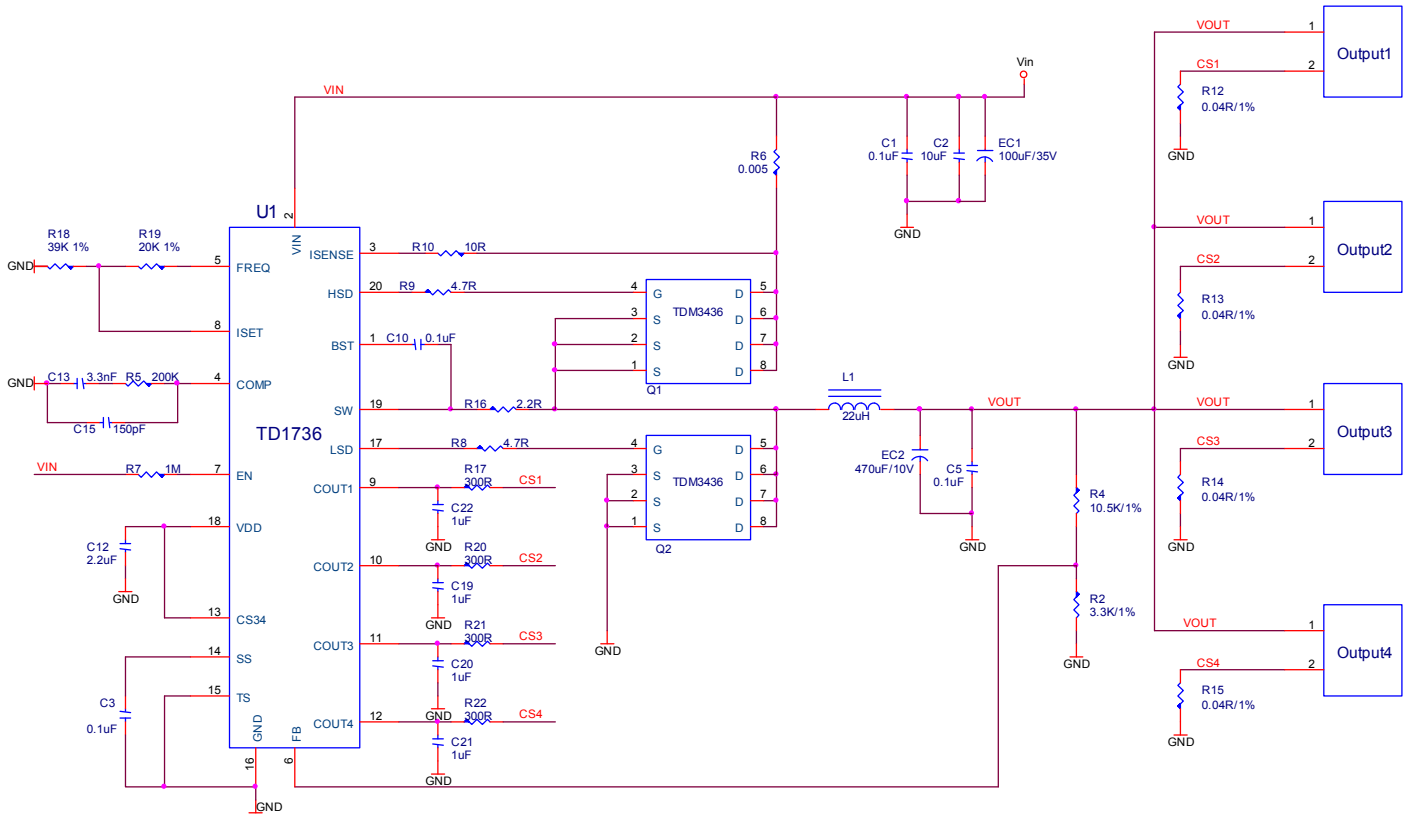

Fig3 4-outputs with OCP(CS1~4) and CC(CS1+CS2+CS3+CS4)

Typical Application Circuit2

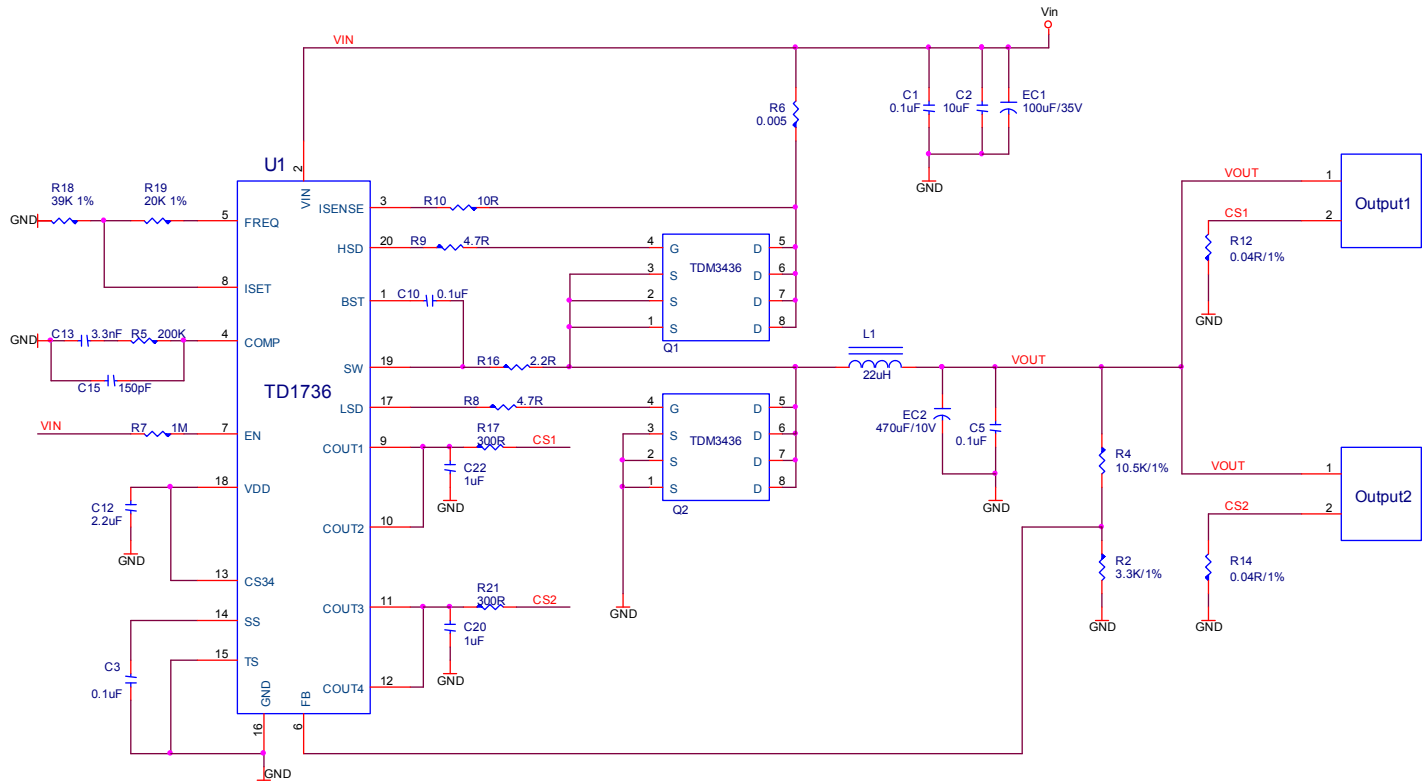

Fig4 2-outputs with OCP and CC(CS1+CS2)

Typical Application Circuit3

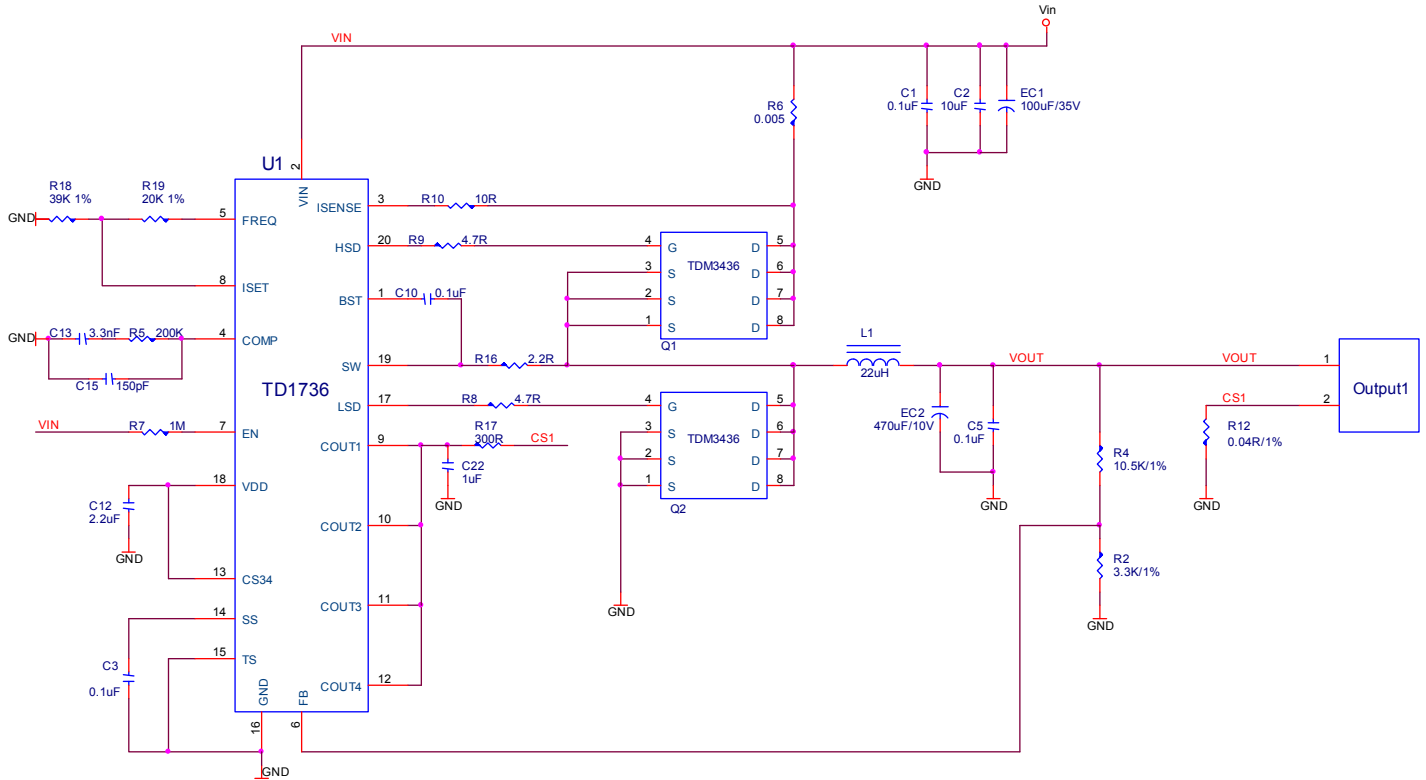

Fig5 1 output with CC.

Function Description

TD1736 operates in a peak-current-mode control to regulate the output voltage. The internal clock initiates the PWM cycle, which turns on the integrated high side power MOSFET. The high-side MOSFET remains on until its current reaches the value set by the COMP voltage. When the power switch is off, it remains off until the next clock cycle begins.

CC/CV Mode Control

TD1736 provides CC/CV function. The Constant output Current control Mode and Constant output Voltage control Mode.

Output Voltage Setting

VFB is the feedback pin and connected to the non-inverting of error amplifier input. The output voltage is adjustable from 1.2V to 28V with a resistor-divider connected with VFB GND and converter's output. Using 1% or better resistors for the resistor-divider is recommended.

The output voltage is determined by the equation:

$$V_{OUT} = V_{FB} * (1 + R1/R2) = 1.2V * (1 + R1/R2)$$

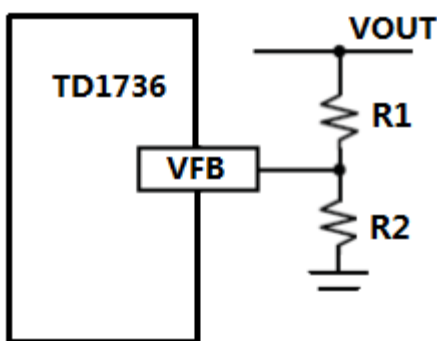

R1 will can program the cable compensation.

Constant Current setting:

At this time Cout1-4 should be lower than the OCP threshold (108mv) . The sum voltage of Cout1-4 pins reaches the voltage on V_{ISET} pin, the system will enter CC mode, the CC

current can be calculated by followings:

$$I_{CC} = I_1 + I_2 + I_3 + I_4$$

$$I_1 * R_{CS1} + I_2 * R_{CS2} + I_3 * R_{CS3} + I_4 * R_{CS4} = V_{ISET} / 2.5$$

Here V_{ISET} = 1.2V * (R18 / (R18 + R19)), R18 and R19 refer to Typical Application Circuit, R_{CS1,2,3,4} are the sense resistors between COUT1,2,3,4 and GND.

Output Cable Resistance Compensation

To compensate for resistive voltage drop across the charger's output cable, the TD1736 integrates a simple, user-programmable cable voltage drop compensation using the impedance at the FB pin. By choosing different R1, we can get different cable voltage drop compensation values. The compensation voltage (Vdelta) can be calculated by:

$$V_{delta} = I_{FB} * R1 = R1 * ((V_{CS1} + V_{CS2} + V_{CS3} + V_{CS4}) - 10mv) / 10K.$$

V_{CS1/CS2/CS3/CS4} are the voltages on the pins Cout1-4. R1 is the resistor between VFB and VOUT.

Over Current limit setting

A drop voltage on the current sensing resistor is over the OCP value, the controller will enter hiccup mode. The Current limit is set by outside resistance (R_{SENSE}), When the cout1 or cout2 or cout3 or cout4 voltage larger than 108mV, the current limit occurs. The Output current limit (I_{OC}) set according to the following equation:

$$I_{OC} = 108mv / R_{CS}$$

Over Temperature Protection (OTP)

TD1736 provides over temperature protection (OTP) . The OTP will shut down the converter when junction temperature exceeds 150°C. Once the junction temperature cools down by approximately 20°C, the controller will resume.

Frequency setting

The FREQ pin is used to set the operation frequency and a 120k~30k ohm resistor is connected FREQ pin and GND. The frequency is decided by the equation: F_{SW} = 12000k / RF, RF is

the resistor between this pin and GND with unit in kohm.

If this pin is floating, the frequency is 200khz.

Output Inductor Selection

The inductor value (L) determines the inductor ripple current, I_{RIPPLE} and affects the load transient response. Higher inductor value reduces the inductor's ripple current and induces lower output ripple voltage. The ripple current and ripple voltage can be approximated by:

$$L = V_{OUT} * (V_{IN} - V_{OUT}) / F_{SW} * I_{RIPPLE} * V_{IN}$$

Where

F_{SW} : the switching frequency of the regulator; V_{IN}/V_{OUT} : input voltage/output voltage;

I_{RIPPLE} is the inductor ripple current and $I_{RIPPLE} = (0.3-0.5)I_{OUT}$

Input Capacitor

A low ESR capacitor is highly recommended. Since large current flows in and out of this capacitor during switching, its ESR also affects efficiency.

The input capacitance should be higher than 100 μ F. The best choice is the ceramic type, however, low ESR tantalum or electrolytic types may also be used. The input capacitor should be placed close to the VIN and GND pins of the IC, with the shortest traces possible. In the case of tantalum or electrolytic types, they can be further away if a small parallel 1 μ F ceramic capacitor is placed right next to the IC.

Output Capacitor

The system requires the output capacitor to maintain the dc output voltage. The characteristics of the output capacitor affect the stability of the regulatory system. A low ESR electrolytic capacitor is recommended for a low output ripple and good control loop stability. For general applications, a 1 μ F ceramic capacitor and a 330 μ F (or more) polymer/electrolytic capacitor are recommended.

Package Information

QFN20L Package Outline Dimensions

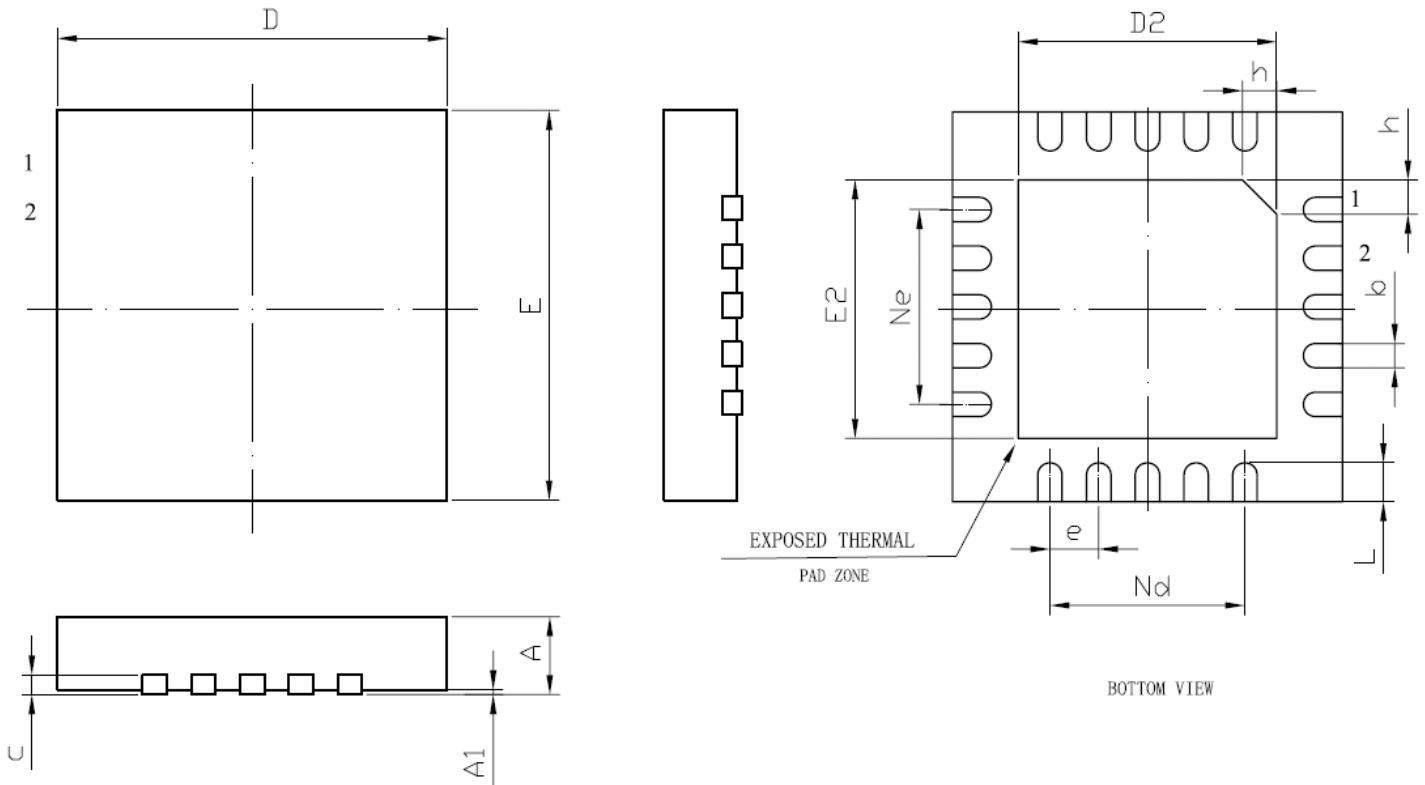

Symbol		A	A1	b	c	D	D2	e	Ne	Nd	E	E2	L	h
Millimeter	MIN	0.7	-	0.18	0.18	3.90	2.55	0.50 BSC	2.00 BSC	2.00 BSC	3.90	2.55	0.35	0.30
	NOM	0.75	0.02	0.25	0.20	4.00	2.65				4.00	2.65	0.40	0.35
	MAX	0.8	0.05	0.30	0.25	4.10	2.75				4.10	2.75	0.45	0.40

Design Notes