

# 4<sup>th</sup> generation of Coromax pulse generators for ESP's

Victor Reyes  
FLSmidth Airtech  
Denmark  
vicr@flsairtech.com

Peter Elholm  
FLSmidth Airtech  
Denmark  
PE@flsairtech.com

## 1 Abstract:

The first plants using the latest generation of Coromax pulse generators for ESP's have been commissioned. The present paper will present the new features developed as well a comparison with competing types of power supplies for ESP's. Among the new features, the use of single IGBT's as main semiconductor switch and extremely narrow pulses can be mentioned. Furthermore the results obtained after the commissioning of a sinter plant producing 15.000 t/d will be given.

## 2 Introduction

The tendency in air pollution regulations is a decrease of the accepted levels for fine particles. E.g. the EU has imposed lower limit on ambient concentration of fine particulate matter (PM2.5). It is well known that pulse energization is the most effective means in charging and filtering fine particulate when using ESP's.

In order to improve the state-of-the-art in pulse energization, Airtech- Air Pollution Control FLSmidth has developed the 4<sup>th</sup> generation of its line of pulse generators. The main goal for the new system was to increase the rate of rise of the ESP voltage by a factor of 2 and in this way to be able to apply higher voltage levels to the ESP. This was obtained in practice by decreasing the pulse width correspondingly. Furthermore, the system is able to apply a higher pulse voltage compared with previous generations. Other improvements have been introduced regarding the manner the high voltage semiconductor switch handles the sparks occurring inside the ESP.

Physically the system comprises one control cabinet and a HV oil tank, like a traditional TR set, where the oil tank is placed on the ESP roof, as shown in Fig. 1.

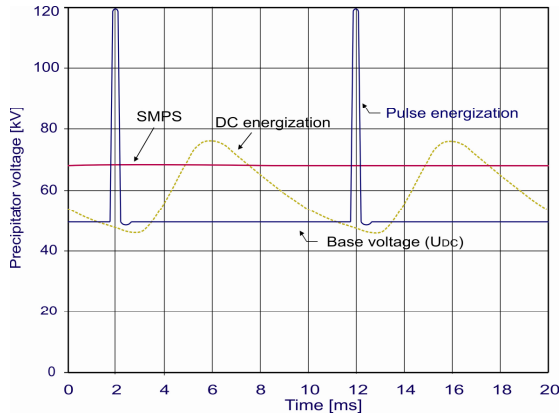

Fig. 1 Coromax HV oil tank

The electrode/collecting system behaves as a capacitance with losses. The Coromax mrk. IV is designed for a **rated load of 115 nF** but it can operate with a wide range of ESP capacitances (40% - 200% of rated value).

The art of pulse energization consists of narrow HV pulses in the range of **tenths of microseconds**, superimposed on a base voltage, which are applied to an ESP field [1], [2] generating negative corona.

The principle is illustrated in Fig. 2 showing the Coromax voltage waveform compared with the one generated by a traditional single-phase TR set (DC-energization). Furthermore, the smooth DC voltage delivered by a SMPS unit is shown. Some of these units can operate in the **so-called intermittent mode** (IE-mode = intermittent energization) giving a DC voltage with high ripple and a variety of degrees of intermittence. But these HV supplies operate in



**Fig. 2 Waveform of the output voltage**

the **millisecond** range with modest  $dv/dt$  in the range of few kV/ms.

The present version of the COROMAX system dealt with in this paper, aims at improving the performance in fine particulate and high resistivity dust collection by halving the pulse width. In this way the  $dv/dt$  applied to an ESP field is doubled (up to 2 kV/ $\mu$ s).

To improve the conditions regarding service and troubleshooting, other requirements were to avoid series connection of power semiconductors and placement in insulating oil. Furthermore, because of an eventual higher sparking level the pulse amplitude has been increased by 10 kV compared with previous generations.

In order to fulfil these requirements a solution with pulse transformer with a suitable transformation ratio and a switch made of high power IGBT's operating at 2.5kV was chosen.

Finally it can be mentioned that considerably improvements have been introduced in the automatic control system.

### 3 Principle of operation of the COROMAX system

A simplified diagram of the main circuit is shown in Fig. 3.

The DC base voltage applied to the ESP is delivered by a controlled HV power supply ( $-U_{DC}$ ). The power for pulse generation is delivered by another controlled HV supply ( $+U_{PS}$ ).

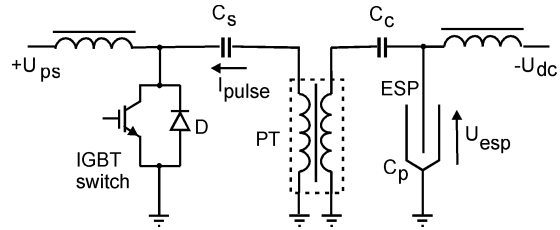
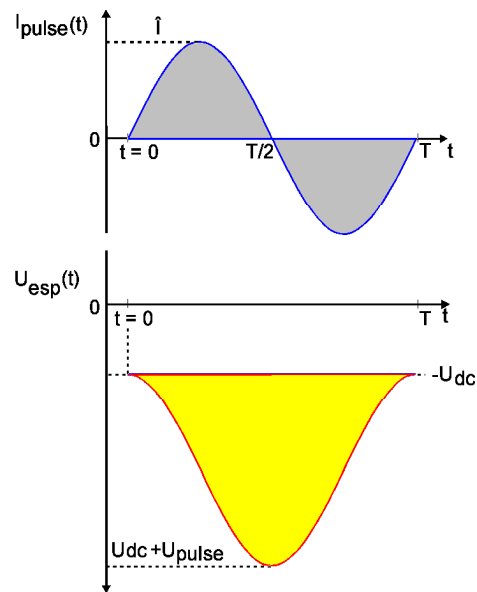

**Fig. 3 Simplified main circuit of a Coromax pulse system**

Before a pulse is generated, the capacitor  $C_S$  is charged to a voltage  $+U_{PS}$  through the primary winding of the pulse transformer. The coupling capacitor  $C_C$  is used for avoiding short-circuit of the DC-power supply and it is charged to the voltage  $U_{DC}$  like the ESP capacitance.

Then a series resonant circuit comprising the storage capacitance  $C_S$ , the coupling capacitance  $C_C$ , the precipitator capacitance  $C_F$  and the leakage inductance of the pulse transformer (PT) is formed. This circuit is closed when the IGBT switch is turned on.

When this happens an oscillation is initiated and a current with the waveform shown in Fig. 4 starts flowing through the IGBT. When the current through the IGBT reaches its zero-crossing ( $T/2$ ), it changes direction and circulates through the reverse diode (D) built in the IGBT module, until it becomes zero. Then the period of the oscillation ( $T$ ) is elapsed and a HV pulse has been generated.



**Fig. 4. Waveforms during a normal high voltage pulse**

The voltage across the ESP and the current through the switch has the waveforms shown in Fig.4. The voltage rating is 60 kVDC and 80 kV pulse, respectively.

The pulse current is a sine wave, where the positive half-cycle corresponds to the IGBT conduction interval and the negative to the reverse diode conduction interval. Its rated value is 9 kA<sub>peak</sub>. The rated pulse width is 75µs. This can be repeated with a frequency, variable between 2 and 100 pps. The rated voltage of the pulse power supply ( $U_{PS}$ ) is 2.5 kV.

The pulse voltage has a waveform corresponding to a shifted cosine wave. The equations describing the waveforms can be found in [1].

The block diagram shown in Fig. 5 illustrates the complete pulse system. In order to cope with the high pulse current level, especially in case of sparks in the ESP, the primary circuit is divided in two equal branches in parallel. Therefore the pulse transformer comprises 2 primary windings, improving the current distribution between the 2 IGBT's. The DC voltage supply ( $U_{DC}$ ) and the pulse supply ( $U_{PS}$ ) are fed from the three-phase AC line.

This voltage level is raised by HV transformers

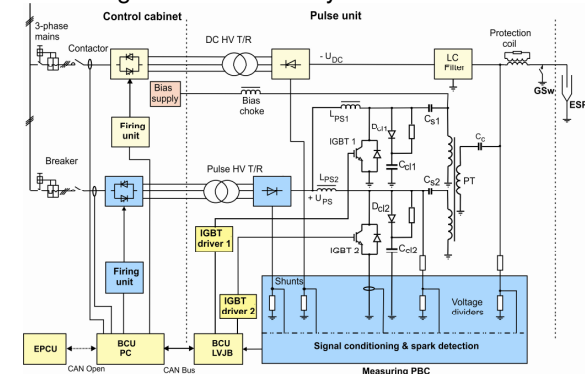

**Fig. 5 Block diagram of the COROMAX**

and rectified by three-phase bridge rectifiers. The output voltages ( $U_{DC}$ ,  $U_{PS}$ ) are controlled by three-phase thyristor controllers by varying the primary voltage of the HV transformer. Each controller receives the firing pulses from a firing PC board.

The output of the DC power supply is passed through a LC filter with capacitive input, whose main function is to keep the base voltage smooth, especially after firing a HV pulse.

The output of the pulse power supply is filtered by  $L_{ps1}$ ,  $L_{ps2}$ ,  $C_{s1}$  and  $C_{s2}$ .

The pulse forming network is the same as the one shown in Fig. 3 with the exception that, in practice, there are 2 parallel branches in the primary circuit. Furthermore, in parallel with each IGBT is connected a clamping network, consisting of a diode  $D_{cl}$  in series with a large capacitor  $C_{cl}$ , which function will be discussed later.

## 4 Automatic control unit

The firing angle for both power supplies is determined by the control unit BCU PC. This is placed in the control cabinet and communicates with control unit BCU LVJB at the HV tank via a CAN Bus. These units include the control strategies, spark classification, monitoring and alarm processing system. The operation of the system is performed from the EPCU (EsP Control Unit), which also takes care of the rapping control and heating of insulators and hoppers. EPCU is common for a number of ESP bus-sections but typically for one ESP chamber.

The control panel of the EPCU is shown in Fig.6.

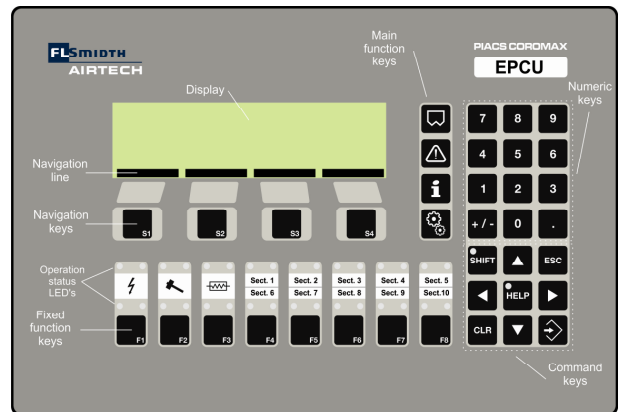

**Fig. 6 Front panel of the control system**

When treating medium and high resistivity dusts, an accurate control of the base voltage is quite important. The EPCU controls its level in a way that the generated 'DC corona current' can be kept at a setpoint of normally a 'few milliamps'. In this way back corona can be avoided.

This 'DC corona current' is the current flowing between two consecutive pulses after the ion cloud generated by the first one has reached the collecting plates. This means that this current has to be measured sampling the corresponding signals just before the next pulse is generated. Because a typical repetition frequency in case of medium dust resistivity is 50 - 60 pps, the control system has a time interval of 17 - 20 ms to perform the measurement. This measurement was not possible in previous generations and may be considered as a major improvement in the new Coromax.

## 5 IGBT switch function

The HV switch is the heart of a pulse system and the most critical situation for the semiconductors used, is the occurrence of sparks.

Normally the sparks occurs around the top of the pulse, but they can also occur earlier or later, depending on the mechanical condition of the ESP and/or the resistivity of the particulate removed by the ESP. These sparks are named pulse sparks.

Occasionally sparks may occur shortly after a pulse and they are named DC-sparks, as only the base voltage is applied to the ESP at the spark instant.

The previous pulse systems used HF thyristors connected in series as a switch [1,2]. In case of sparks the switch is exposed to a considerable overvoltage. To cope with this situation the switch can be oversized using a larger number of elements in series, which is too expensive. The normal solution used is generation of protection firing pulses. Because of the connection of many thyristors in series, this kind of protection is critical, as explained in [2].

By using an IGBT switch instead, this can be turned off when a spark is detected. This gives a much more simple protection principle for the IGBT switch. When the IGBT's are turned off it is necessary to have an alternative path for the energy stored in the system. This function is performed by the clamping diode  $D_{cl}$  and the clamping capacitor  $C_{cl}$ . When the IGBT's are turned off after detection of a pulse spark, the

clamping diode is biased in the forward direction and the current surge pulse charges the clamping capacitor. If this is sufficient large, the voltage increase in  $C_{cl}$  is limited and the overvoltage across the IGBT's can be kept at few hundred volts.

A typical example is seen in Fig. 6, showing what happens in case of a pulse spark.

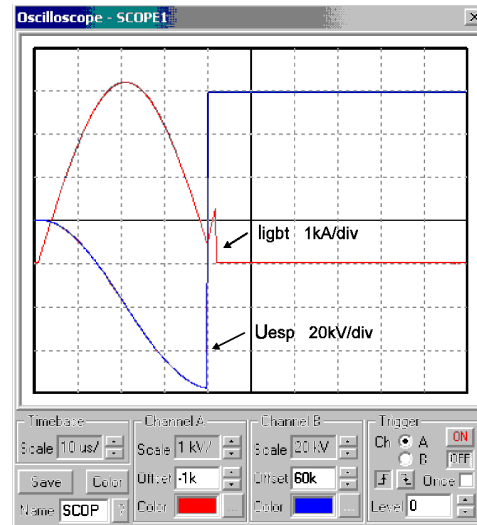

(a)

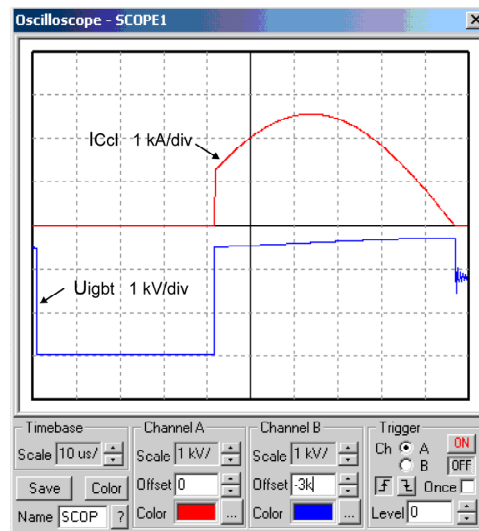

(b)

**Fig. 7 Waveforms in case of pulse spark.**

These waveforms are obtained with the simulation program POWERSIM and correspond to rated values. Fig. 7.a shows a pulse spark occurring on top of the pulse just after the zero-crossing of the IGBT current (**Iigt**). As seen the ESP voltage (**Uesp**) drops very fast from 140 kV to 0. The IGBT current

changes direction and begins to increase, but after a delay of few microseconds the IGBT's are turned off and the pulse current commutates to the clamping network. The current through the clamping capacitor ( $I_{Ccl}$ ) is shown in Fig.7.b.

Here it is seen that  $C_{cl}$  is charged by this current and the overvoltage applied to the IGBT's is limited to about 200 V. Fig. 7 shows the currents in one parallel branch only. During a normal pulse the peak current through one IGBT is 4.2 kA. Fig. 7 also shows that the IGBT's are not exposed to current surges, because these are overtaken by the clamping network made of passive components.

In case of DC-sparks the IGBT's are already turned off, so the only possible current path for the surge is the clamping network.

This solution has been patented in a number of countries, the EU and EEUU among them.

The IGBT's are fired by a commercially existing IGBT driver, They are physically placed in a LV junction box (LVJB) attached to the oil tank as seen in Fig. 8.

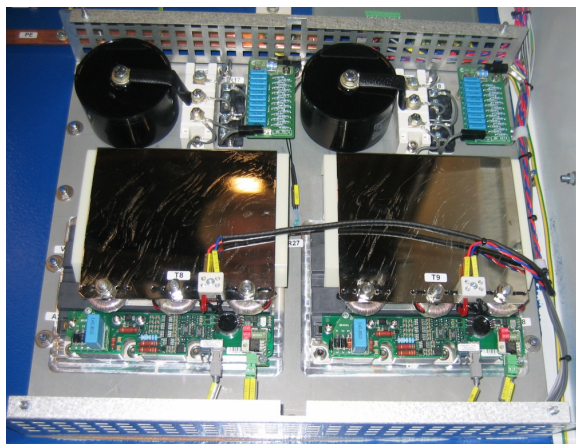

**Fig. 8 IGBTs mounted in LVJB**

The IGBT's are mounted on a heat sink with cooling fins, which is in contact with the oil inside the HV tank. Fig. 9 shows one of the utilized IGBT's together with the corresponding IGBT driver.

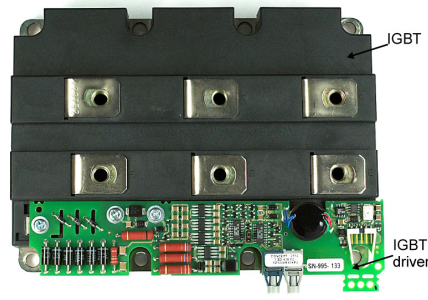

**Fig. 9 1200A/3300 V IGBT used as switch**

As shown, the switch is implemented with commercially available elements and no series connection is used. The switch is mounted in air, so measurements and eventual troubleshooting and replacement is much easier.

## 6 Practical experiences

After a long test of the prototype in a Danish power plant a number of units have been sold. At the moment more than 20 units are in operation, mainly in sinter strand plants and also in a power plant.

### 6.1 Electrical operation

The main waveforms are easy to collect via existing BNC connectors. The waveforms corresponding to a normal pulse are shown in Fig. 10.

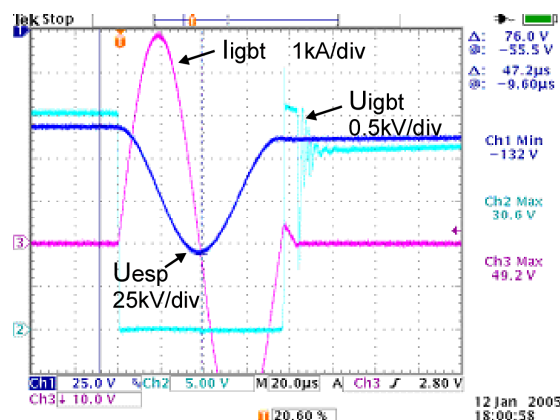
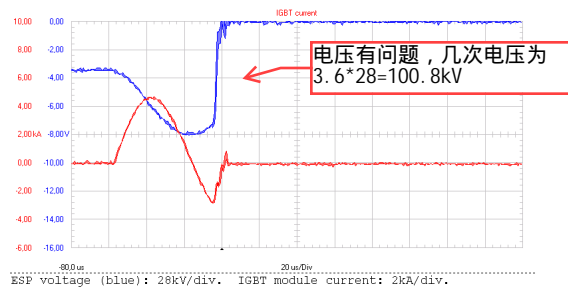

**Fig. 10 ESP and IGBT voltage and IGBT current during a normal pulse.**

The voltage across the IGBT is 2.5 kV (rated value) causing a peak current of about 4.8 kA flowing through the switch and a total ESP voltage of 132 kV ( $U_{DC} = 55$  kV). The pulse width is 78  $\mu$ s.

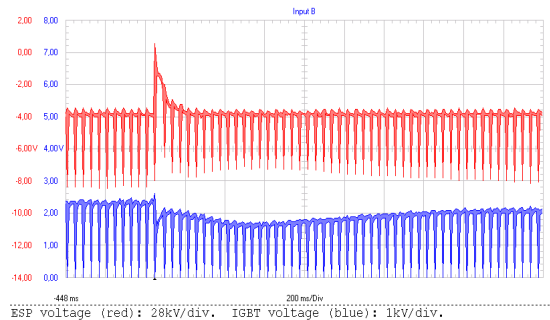

Fig. 11 illustrates a pulse spark occurring after the top of the pulse, showing the ESP voltage and the current through one IGBT. It is seen that the current through the IGBT is only flowing during the normal pulse, but when the sparks occurs the IGBT is turned off. The surge current is then overtaken by the clamping network, as illustrated in Fig. 7.



**Fig. 11 ESP voltage and IGBT current during a pulse spark.**

During normal (repetitive) operation the waveform of the ESP voltage is shown in Fig. 12.



**Fig. 12 ESP voltage and IGBT voltage at normal repetitive operation.**

Fig. 12 shows also the occurrence of a spark and the following voltage recovery. It is also seen the amplitude of the pulses follow the envelope of the IGBT voltage very close.

## 6.2 Site experiences

### 6.2.1 Plant No. 1

The first system (prototype) was installed in a Danish power plant, the unit #3 at Nordjyllandsværket. Unit #3 has a nominal load of 350 MW and the boiler is fired with different coal blends. The load varies typically between 80 and 100% according to the daily demands. The typical coal blend during the test period were a mix of Russian, Indonesian and South African or Russian, Colombian and South

African coal, producing a medium resistivity flyash.

The ESP is from FLS comprising two chambers, with 4 bus-sections each, energized with 8 third generation Coromax systems. Each Coromax energizes 4320 m<sup>2</sup> (400 mm wide spacing) of collecting area, corresponding to a capacitive load of 120 nF. The rated mean current is 600 mA.

The gas flow is 32.000m<sup>3</sup>/min and the dust load is 18.5 gr/Nm<sup>3</sup> dry @ 6% O<sub>2</sub>.

The new Coromax energizes the 2<sup>nd</sup> bus-section of the West chamber. A switch box was mounted allowing and easy change-over with the existing pulse system. The electrical operation is best illustrated by the CVC shown in Fig. 13.

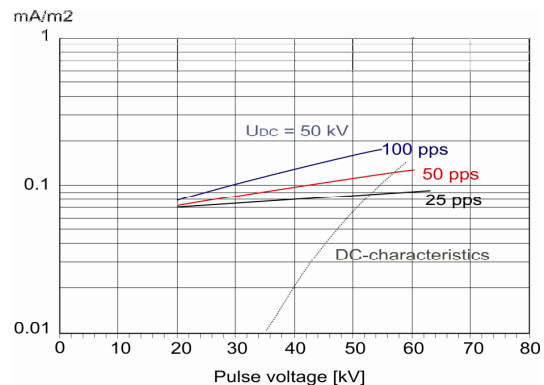

**Fig. 13 Pulse and DC I-V characteristics**

As shown, total voltages (DC+pulse) of 113 kV are possible ( $U_{DC} = 50$  kV). The increase in the pulse voltage compared with the old Coromax is 4-6 kV, but because the prototype only energizes 1/8 of the ESP, no appreciable emission reduction was observed. The emission level is below 50 mg/Nm<sup>3</sup>, typically 35 mg/Nm<sup>3</sup>.

Moreover, Fig. 13 clearly indicates the outstanding feature of pulse energization, where the ESP current can be varied independently of the voltage, just by varying the pulse repetition frequency.

## 6.2.2 Plant No. 2

The first commercial units were commissioned in 2010 at the waste gas ESP at sinter plant in South America.

The sinter waste gas is characterized by fine particulate high resistivity dust and the Coromax with its individual control of voltage and current is in particular appropriate for that process.

A new ESP was delivered comprising two chambers with 3 sections each. Both inlet sections are energized with single phase TR's and the other 4 sections with 4<sup>th</sup> generation Coromax systems. See Fig. 1.

The plant has sinter strand of 450 m<sup>2</sup> designed for a production of 15000 t/day. The ESP is designed for a gas flow of 38.868 m<sup>3</sup>/min and an inlet temperature of 160°C. The guaranteed dust emission is 50 mg/Nm<sup>3</sup> (dry).

The capacitive load for each Coromax system is about 145 nF, i.e. 25 % higher than rated load. The rated pulse voltage is 80 kV, the rated base voltage is 60 kV and the rated mean ESP current is 600 mA.

The performance test was made with a production of 15800 t/day, a gas flow rate of 29245 m<sup>3</sup>/min and a temperature about 165°C. The result was 5 mg/Nm<sup>3</sup> that was much below the guarantee limit. Some of the lower value may relate to the lower gas flow rate. However, the main part may relate to the unique feature of the new Coromax.

## 6.2.3 Plant No. 3

The second commercial units were also installed in a sinter plant waste gas ESP in South America and were commissioned late in 2010. An existing 2 chambers ESP, each with 3 sections, were furnished with new internals and 6 Coromax systems.

The plant has a sinter strand of 146 m<sup>2</sup> designed for a production of 6100 t/day. The ESP is designed for a gas flow of 18.350 m<sup>3</sup>/min and an inlet temperature of 110°C. The guaranteed dust emission is 30 mg/Nm<sup>3</sup> (dry).

The capacitive load of each Coromax is about 90 nF. The rated pulse voltage is 80 kV, the

rated base voltage is 60 kV and the rated mean ESP current is 600 mA.

The performance test was made with a production of 5425 t/day, a gas flow rate of 19.088 m<sup>3</sup>/min and an inlet temperature about 90°C. The result was 6 mg/Nm<sup>3</sup>, that is in a very safe distance to the guaranteed limit. With operational data close to the design, the much better results relate solely to the Coromax features.

## 7 Conclusions

It has been possible to include improvements with respect to previous Coromax generations. Among them, the following can be mentioned:

- Almost twice higher dv/dt applied to the ESP as the pulse width is now only 75 µs.
- 10 kV higher pulse voltage allowing a better particle charging.
- Modern up-to-date HV switch with commercially available IGBT's mounted in air. No series connected modules are needed, making possible an easy maintenance and troubleshooting.
- More simple and efficient way of coping with sparks, due to the turn-off capabilities of IGBT's.
- Up-to-date automatic control system, including control of rappers and heaters.

Regarding emission guarantees, these have been achieved without problems. Further, the results have been beyond expectation.

## 8 Literature

- [1] K. Parker. 'Electrical operation of electrostatic precipitators'. IEE Power and Energy Series. 2003.
- [2] V. Reyes 'Semiconductor switch for HV pulse generation'. 20<sup>th</sup> Conference on Power Conversion, Munich, 1990. Germany.