

Subject
OB2365E+2004A Demo Board Manual

Board Model: AD12V5A 2365E+2004A
 Doc. No.: OB_DOC_DBM_2365E+2004A00

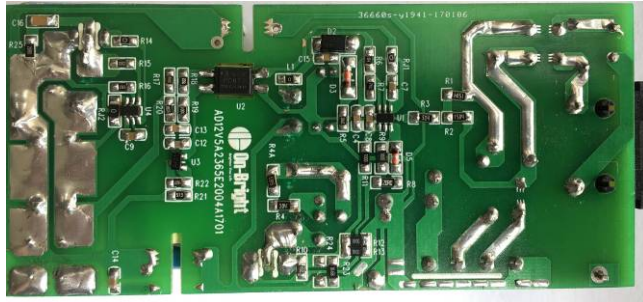

Key Features

- Standby Power < 60mW(230Vac input, no load)
- Averaged efficiency more than 89.0% @115/230Vac at AWG16 1.5M cable end
- High performance OCP compensation
- Frequency shuffling technology for improved EMI performance
- EMI passed EN55022 and FCC Part15 Class B test with more than 6dB margin
- Average efficiency meet COC V II, 1.5% margin
- Offers comprehensive protection coverage with auto-recovery including OCP, OLP, UVLO, OVP, and Brownout protection

Revision History

Revise Date	Version	Reason/Issue
2017-4-6	00	First issue

Contents Index

1	Adapter Module Specification	4
1.1	Input Characteristics	4
1.2	Output Characteristics	4
1.3	Performance Specifications	4
1.4	Protection Features	4
1.5	Environments	4
2	Adapter Module Information	5
2.1	Schematic	5
2.2	Bill of material	5
2.3	PCB Gerber File	7
2.4	Transformer Design	8
2.4.1	Transformer Specification	8
2.4.2	Transformer Winding data	8
2.5	Adapter Module Snapshot	9
3	Performance Evaluation	10
3.1	Input Characteristics	11
3.1.1	Input current and Standby power	11
3.1.2	Efficiency	11
3.2	Output Characteristics	12
3.2.1	Line Regulation & Load Regulation	12
3.2.2	Ripple & Noise	12
3.2.3	Overshoot & Undershoot	13
3.2.4	Dynamic Test	14
3.2.5	Time Sequence	14
3.3	Protections	16
3.3.1	Over Current Protection (OCP)	16
3.3.2	Over Voltage Protection (OVP)	16
3.3.3	Over Load Protection (OLP)	17
3.4	Thermal Test	17
3.5	EMI Test	18
3.5.1	Conduction EMI Test	18
3.5.2	Radiation EMI Test	20
4	Other important waveform	21
4.1	CS, FB, Vdd & Vds waveform at no load/full load	21
4.2	Synchronous rectification Sgate, Svdd & Vd at no load/full load	21
4.3	Vds waveform at full load, start/normal/output short	22
4.3.1	Vds at full load, start/normal/output short	22
4.3.2	Vds, Vds_sr at full load, start waveform	22
4.3.3	Vds, Vds_sr at full load, normal waveform	23
4.3.4	Vds, Vds_sr at full load, output short waveform	23

Figures Index

Fig. 1 R&N waveform @90Vac; no load.....	12
Fig. 2 R&N waveform @90Vac; full load	12
Fig. 3 R&N waveform @264Vac; no load.....	12
Fig. 4 R&N waveform @264Vac; full load	12
Fig. 5 Overshoot waveform @90Vac; full load	13
Fig. 6 Overshoot waveform @90Vac; no load.....	13
Fig. 7 Overshoot waveform @264Vac; full load	13
Fig. 8 Overshoot waveform @264Vac; no load.....	13
Fig. 9 Undershoot waveform @90Vac; full load	13
Fig. 10 Undershoot waveform @264Vac; full load	13
Fig. 11 Dynamic waveform @90Vac input.....	14
Fig. 12 Dynamic waveform @264Vac input	14
Fig. 13 Turn on delay waveform @90Vac; full load	14
Fig. 14 Turn on delay waveform @240Vac; full load	14
Fig. 15 Hold up time waveform @100Vac; full load	15
Fig. 16 Hold up time waveform @240Vac; full load	15
Fig. 17 OVP waveform @90Vac; no load.....	16
Fig. 18 OVP waveform @264Vac;no load.....	16
Fig. 19 OLP waveform @90Vac; over load	17
Fig. 20 OLP waveform @264Vac;over load	17
Fig. 21 CS,FB,Vdd&Vds wave form @90Vac; no load.....	21
Fig. 22 CS,FB,Vdd&Vds wave form @90Vac; full load.....	21
Fig. 23 CS,FB,Vdd&Vds wave form @264Vac; no load.....	21
Fig. 24 CS,FB,Vdd&Vds wave form @264Vac; full load.....	21
Fig. 25 Synchronous rectification Sgate, Svdd & Vd wave form @90Vac; no load	21
Fig. 26 Synchronous rectification Sgate, Svdd & Vd wave form @90Vac; full load.....	21
Fig. 27 Synchronous rectification Sgate, Svdd & Vd wave form @264Vac; no load	22
Fig. 28 Synchronous rectification Sgate, Svdd & Vd wave form @264Vac; full load.....	22
Fig. 29 Vds start up wave form @264Vac; full load	22
Fig. 30 Vds_sr start up wave form @264Vac; full load	22
Fig. 31 Vds normal wave form @264Vac; full load	23
Fig. 32 Vds_sr normal wave form @264Vac; full load	23
Fig. 33 Vds output short wave form @264Vac; full load	23
Fig. 34 Vds_sr output short wave form @264Vac; full load	23

Tables Index

Table 1 Input current at full load	11
Table 2 Standby power at no load	11
Table 3 Efficiency.....	11
Table 4 Line Regulation & Load Regulation	12
Table 5 Ripple & Noise measure results	12
Table 6 Overshoot/undershoot measurement results	13
Table 7 Output voltage under dynamic test.....	14
Table 8 Turn-on delay /hold-up measurement results	14
Table 9 OCP value vs. input voltage.....	16
Table 10 Load OVP test result.....	16

1 Adapter Module Specification

1.1 Input Characteristics

- AC input voltage rating 100Vac ~ 240Vac
- AC input voltage range 90Vac ~ 264Vac
- AC input frequency range 47Hz ~ 63Hz
- Input current 1.8 Arms max.

1.2 Output Characteristics

- Output Voltage 12V
- Output Tolerance ±5%
- Min. load current 0A
- Max. load current 5A

1.3 Performance Specifications

- Max. Output Power 60W
- Standby Power <60mW @ 230V/50Hz, no load
- Efficiency >89.0%, Meet COC V II
- Line Regulation ±2%
- Load Regulation ±5%
- Ripple and Noise <120mVpk-pk
- Hold up Time 10m Sec. Min. @100Vac with full load
- Turn on Delay Time 2 Sec. Max. @100Vac with full load

1.4 Protection Features

- Short Circuit Protection Output shut down with auto-recovery
- Over Voltage Protection Output shut down with auto-recovery
- Over Current Protection Output shut down with auto-recovery
- Secondary Rectifier Short Protection Output shut down with auto-recovery

1.5 Environments

- Operating Temperature 0°C to +40°C
- Operating Humidity 20% to 90% R.H.
- Storage Temperature -40°C to +60°C
- Storage Humidity 0% to 95% R.H.

2 Adapter Module Information

2.1 Schematic

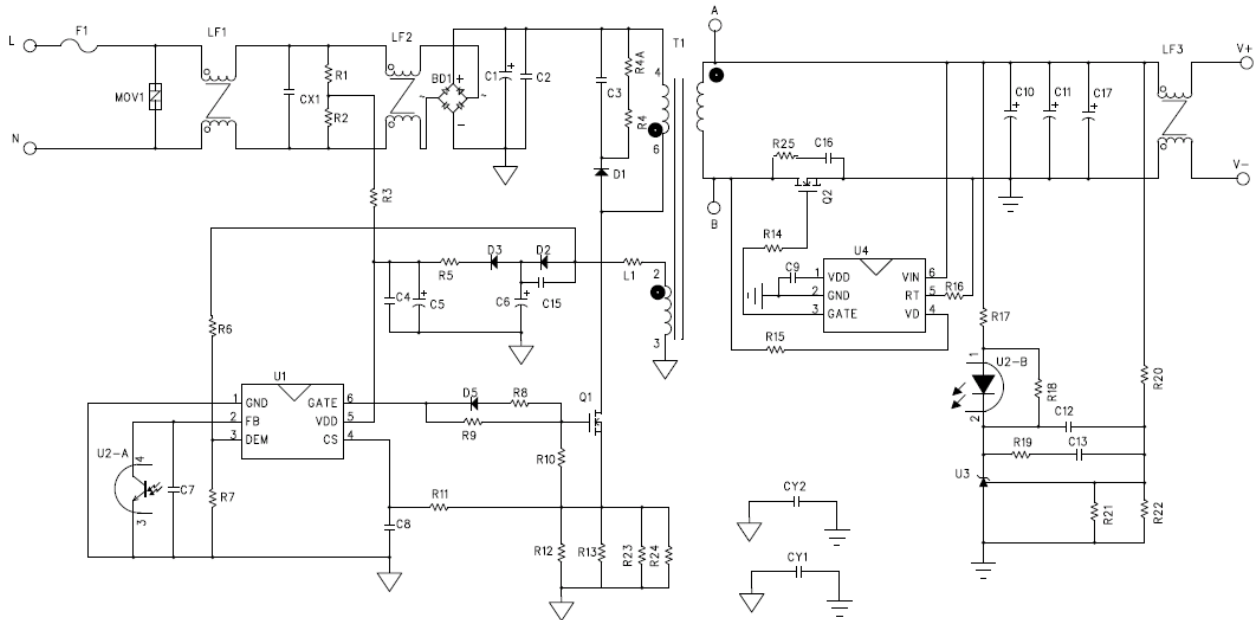

2.2 Bill of material

Position	Description	QTY
BD1	Diode, bridge recovery, GBL406, 4A/ 600V	1
C1	Capacitor, aluminum electrolytic, AiSHi 120uF/400V, 16mm*25mm,105℃, ±20%	1
C2	Capacitor, ceramic,10nF /1KV, -40/105℃,±20%	1
C3	Capacitor, metal poly, CBB,3.3nF/630V, 105℃,±20%	1
C4	Capacitor, ceramic,100nF/50V, X7R, ±10%,SMD0805	1
C5	Capacitor, aluminum electrolytic, 3.3uF/50V, 105℃,±20%	1
C6	Capacitor, aluminum electrolytic, 22uF/50V, 105℃,±20%	1
C7	Capacitor, ceramic,1nF/50V, X7R, ±10%,SMD0805	1
C8	Capacitor, ceramic,150pF/50V, X7R, ±10%,SMD0805	1
C9	Capacitor, ceramic,1uF/50V, X7R,±10%,SMD0805	1
C10,C11	Capacitor, aluminum electrolytic, 1000uF/16V, 105℃,±20%	2
C12	Capacitor, ceramic,47pF/50V, X7R, ±10%,SMD0805	1
C13	Capacitor, ceramic,22nF/50V, X7R, ±10%,SMD0805	1
C15	Capacitor, ceramic,470pF/50V, X7R, ±10%,SMD0805	1
C16	Capacitor, ceramic,2.7nF/1kV, X7R, ±10%,SMD1206	1
C17	EC, 470UF 16V Low ESR, Φ6.3*11mm	1
CON1	AC SOCKET,2.5A/250Vac,2PIN	1
CX1	Capacitor, X2, 0.47uF/275VAC, 105℃,±20%	1
CY1	Capacitor, Y1,disk, 2.2nF /250VAC, 105℃,±20%	1
D1	Diode , 1N4007, 1A/1kV	1
Bead core	For cathode of D1, Φ3.5*1.5*4mm	1
D2	Diode , RS1J, 1A/600V SMD	1

D3,D5	Diode , 1N4148 0.5A/75V SMD	2
F1	Oblong(长方形) Fuse, 3.15A250V	1
LF1	Inductor, choke,dual winding,420uH min, core12*6*4mm, Φ0.5mm*2P*10Ts	1
LF2	Inductor, choke,dualwinding,30Mh min,TDG core18*10*8mm, Φ0.5mm*50Ts*2	1
LF3	Inductor, choke,dual winding,15uH min, core8*4*3mm, Φ0.5mm*2P*7Ts	1
MOV1	MOV 471KD10	1
Q1	MOSFET,MOS power N-channel, SK2843, 10A/600V, TO-220	1
Q2	MOSFET,MOS power N-channel, FDP036N10A, 100V/3.6m Ω , TO-220	1
RJ1,	Resistor, chip, 20R,1/8W,±5%,SMD0805	1
RJ2	Resistor, chip, 0R ,1/4W,±5%,SMD1206	1
R1,R2	Resistor, chip, 1.5M ,1/4W,±5%,SMD1206	2
R3	Resistor, chip, 510K ,1/4W,±5%,SMD1206	1
R4	Resistor, chip, 100K,1/4W,±5%,SMD1206	1
R4A	Resistor, chip, 68K,1/4W,±5%,SMD1206	1
R5	Resistor, chip, 2R ,1/8W,±5%,SMD0805	1
R6	Resistor, chip, 100K ,1/8W,±5%,SMD0805	1
R7	Resistor, chip, 27K,1/8W,±5%,SMD0805	1
R8	Resistor, chip, 20R,1/4W,±1%,SMD1206	1
R9	Resistor, chip, 100R,1/4W,±1%,SMD1206	1
R10	Resistor, chip, 20K ,1/8W,±5%,SMD0805	1
R11	Resistor, chip, 100R ,1/4W,±1%,SMD1206	1
R12,R13	Resistor, chip, 1R ,1/4W,±1%,SMD1206	2
R14, L1	Resistor, chip, 0R ,1/8W,±5%,SMD0805	2
R15	Resistor, chip, 56R ,1/8W,±5%,SMD0805	1
R16	Resistor, chip, 33K ,1/8W,±5%,SMD0805	1
R17	Resistor, chip, 680R ,1/8W,±5%,SMD0805	1
R18	Resistor, chip, 15K ,1/8W,±5%,SMD0805	1
R19	Resistor, chip, 3K ,1/8W,±5%,SMD0805	1
R20	Resistor, chip, 180K,1/8W,±5%,SMD0805	1
R21	Resistor, chip, 51K,1/8W,±1%,SMD0805	1
R22	Resistor, chip, 560K ,1/8W,±1%,SMD0805	1
R23	Resistor, chip, 0.91R ,1/4W,±1%,SMD1206	1
R25	Resistor, chip, 20R,1/4W,±1%,SMD1206	1
T1	Transformer, Lp=660uH ,10KHz/1V, PQ3220, PC40	1
U1	IC,PWM controller, OB2365E, SOT-6	1
U2	IC, photo coupler ,PC817B	1
U3	IC, AS431, SOT-3	1
U4	IC, synchronous rectification controller, OB2004A, SOT-6	1
PCB	AD12V5A 2365E2004A 1701	1
Jump	JUMP1 (Tube)	1
R24,CY2	N.C.	2

2.3 PCB Gerber File

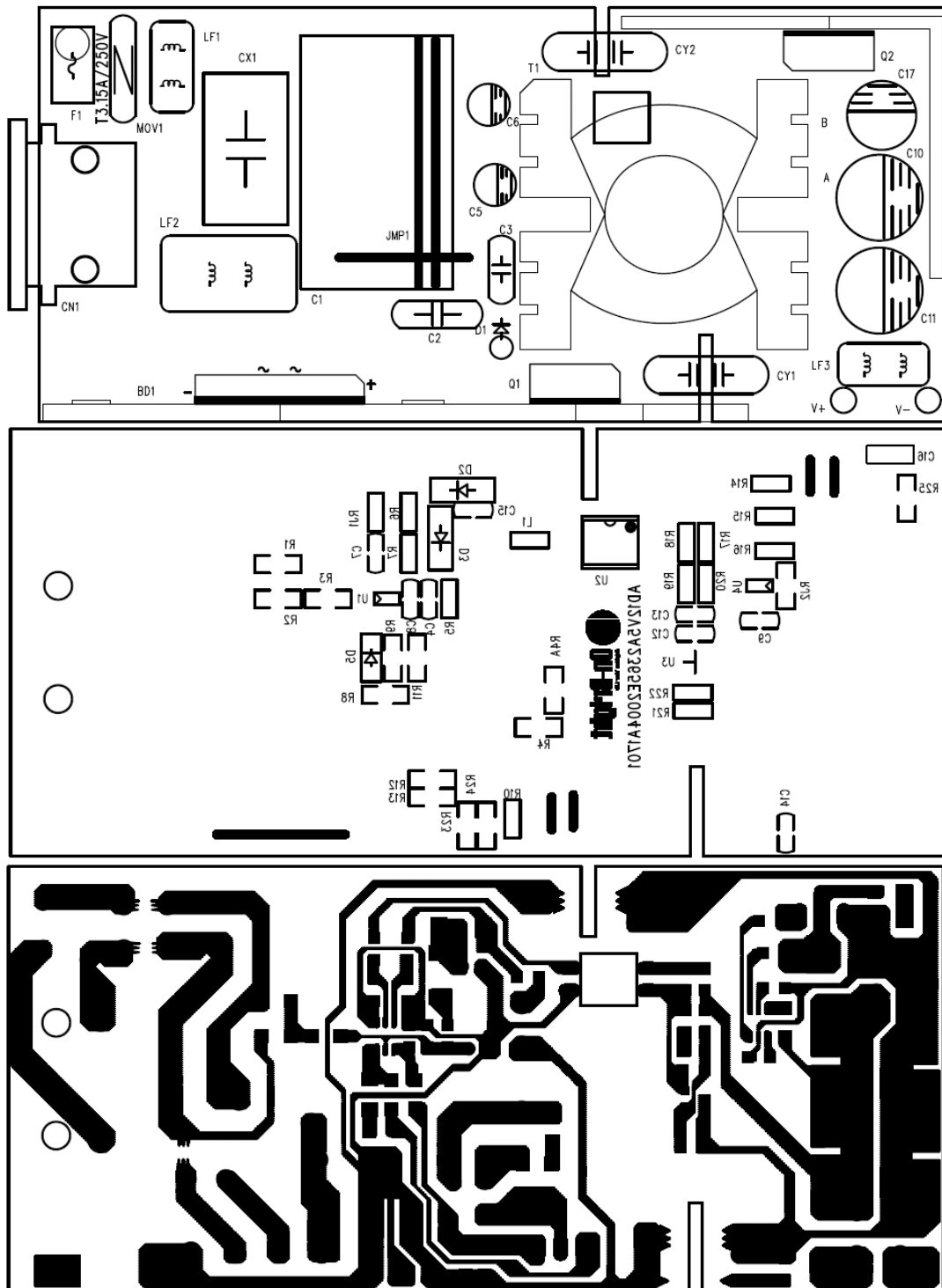

2.4 Transformer Design

2.4.1 Transformer Specification

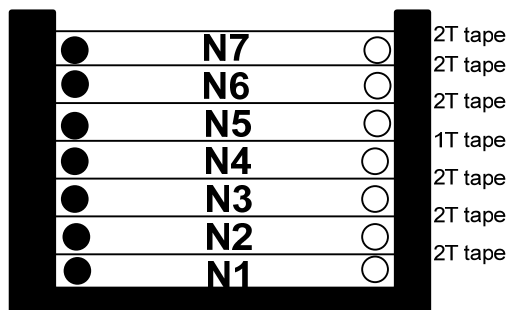
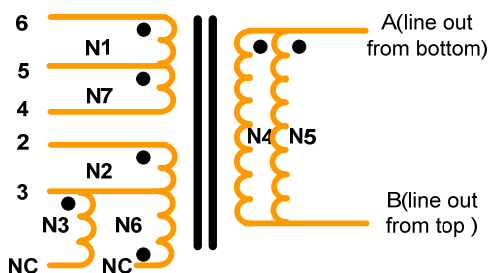

Bottom

Note:

1. Bobbin: PQ3220
2. Core material: TDK PC 40
3. L6-4=660u H +/- 5%. (at: 10 K Hz, 1 V)

2.4.2 Transformer Winding data

No.	Winging	Material	Start	Turns	Finish	Remark
1	N1	Φ0.55*1 2UEW	6	16	5	
2	TAPE	TAPE W=10mm (Y)		2		
3	N2	Φ0.18*4 2UEW	2	4	3	居中密绕
4	TAPE	TAPE W=10mm (Y)		2		
5	N3	Φ0.18*3 2UEW	3	15	NC	
6	TAPE	TAPE W=10mm (Y)		2		
7	N4	Φ0.5*3 triple insulated wire	A	4	B	
8	TAPE	TAPE W=10mm (Y)		1		
9	N5	Φ0.5*3 triple insulated wire	A	4	B	
10	TAPE	TAPE W=10mm (Y)		2		
11	N6	Φ0.18*3 2UEW	NC	15	3	
12	TAPE	TAPE W=10mm (Y)		2		
13	N7	Φ0.55*1 2UEW	5	16	4	
14	TAPE	TAPE W=10mm (Y)		2		

备注: 变压器铁芯必须用胶带完全包住, 且包 2 层, 所有进出线都要加 tube, 铁芯外包一圈 copper 接 Pin3。

2.5 Adapter Module Snapshot

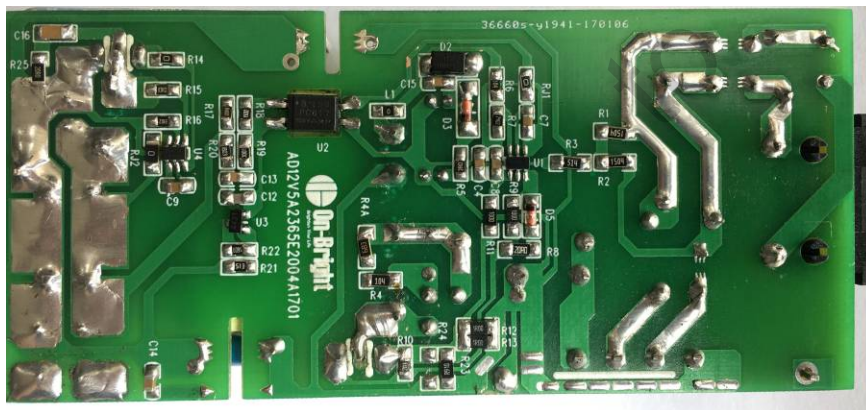

3 Performance Evaluation

All measurements were taken at room temperature, AWG16 1.5m Cable end.

Performance Highlights

- No load standby power under 60mW@230VAC
- Averaged efficiency more than 89.0%@115VAC&230VAC
- EMI passed EN55022 and FCC Part15 Class B test with more than 6dB margin.

Characterization Results Summary

Test Item	Test result
1. Input characteristics	
Input current (90V/60Hz, full load)	1.3497A
Standby power at no load (230Vac)	55mW
Averaged Efficiency (115/230 Vac, 25%~100% load for Cable end)	90.61%/91.06%
2. Output characteristics	
Line regulation	0.05%
Load regulation	2.76%
Ripple & noise	<120mV
Over shoot	5% Max
Dynamic test	±372mV
3. Time sequence (100Vac, Full load)	
Turn on delay time	1.9S
Hold up time	10.13ms
4. Protections	
Over Voltage protection	OK
Over Current protection (90Vac ~264Vac)	OK
Short Circuit protection	OK
Secondary Rectifier Short Protection	OK

Test Equipments

Item	Vender	Module
AC Source:	WEST	WEW1010
Digital Power Meter	YOKOGAWA	WT210
Electrical Load	Prodigit	3315C
Oscilloscope	LeCroy	WS424
Multimeter	VICTORY	VC9807A
Thermal	FLUKE	HS2

3.1 Input Characteristics

3.1.1 Input current and Standby power

The module was tested at different input voltages (from 90Vac to 264Vac)

Table 1 Input current at full load

Input Voltage	90V/60Hz	115V/60Hz	230V/50Hz	264V/50Hz
Input Current(A)	1.3497	1.1442	0.6680	0.5948

Table 2 Standby power at no load

Input Voltage	90V/60Hz	115V/60Hz	230V/50Hz	264V/50Hz
Pin (mW)	27	31	55	69

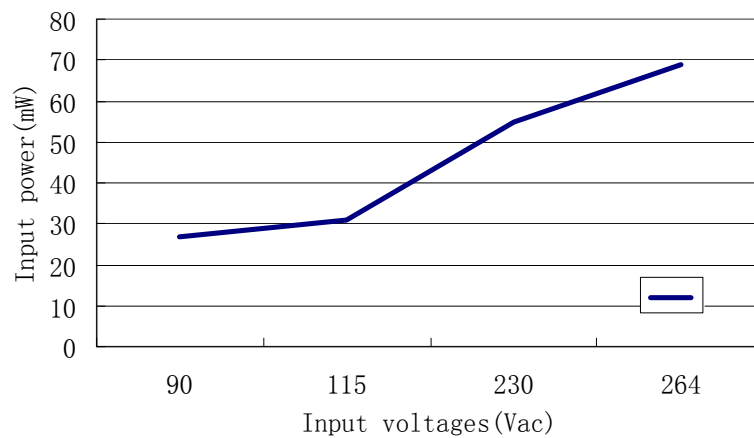

No-load Input Power vs. Input Line Voltage

3.1.2 Efficiency

Table 3 Efficiency

Input voltage	100%	75%	50%	25%	Aver. Eff.	Spec. COC VII
115Vac/60HZ	89.15	89.84	91.70	91.73	90.61%	>89.0%
230Vac/50HZ	90.20	91.66	91.51	90.85	91.06%	

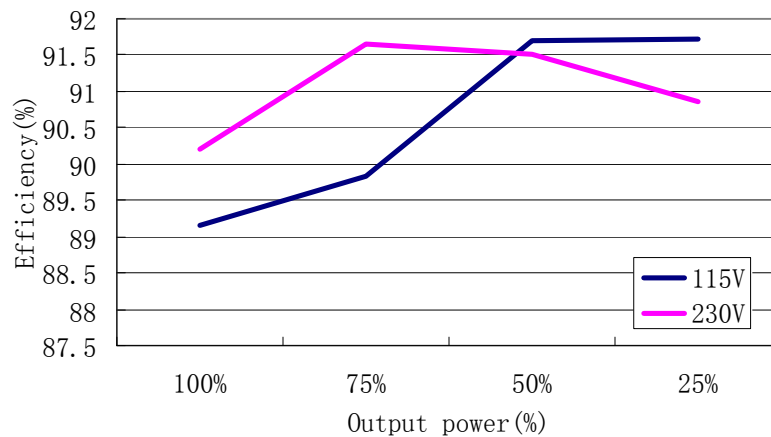

Efficiency vs. Percent of Rated Output Power

3.2 Output Characteristics

3.2.1 Line Regulation & Load Regulation

Table 4 Line Regulation & Load Regulation

Input Voltage	Output Voltage (V)			Load Regulation ($\leq 5\%$)
	No Load	Half Load	Full Load	
90V/47Hz	12.282	12.142	11.999	2.35
115V/60Hz	12.282	12.141	11.999	2.35
230V/50Hz	12.282	12.141	12.000	2.35
264V/63Hz	12.282	12.140	11.999	2.35
Line Regulation ($\leq 2\%$)	0.00	0.02	0.01	

3.2.2 Ripple & Noise

Table 5 Ripple & Noise measure results

Input Voltage	R&N (mV)		Waveform
	No Load	Full Load	
90Vac/60HZ	34	98	Fig.1, Fig.2
115Vac/60HZ	35	85	
230Vac/50HZ	43	86	
264Vac/50HZ	42	86	Fig.3, Fig.4

Note: Ripple & noise were measured at AWG16 1.5M CABLE end with a 0.1uF/100V ceramic cap connected in parallel with a 10uF/50V Electrolytic cap. Bandwidth was limited to 20MHz.

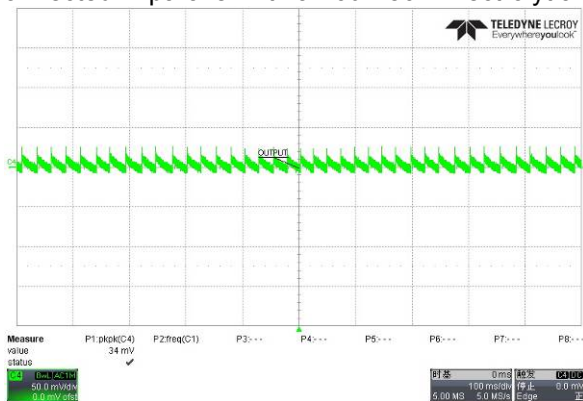

Fig. 1 R&N waveform@90Vac; no load

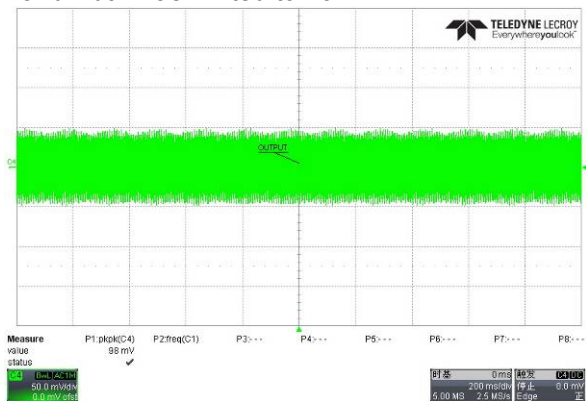

Fig. 2 R&N waveform@90Vac; full load

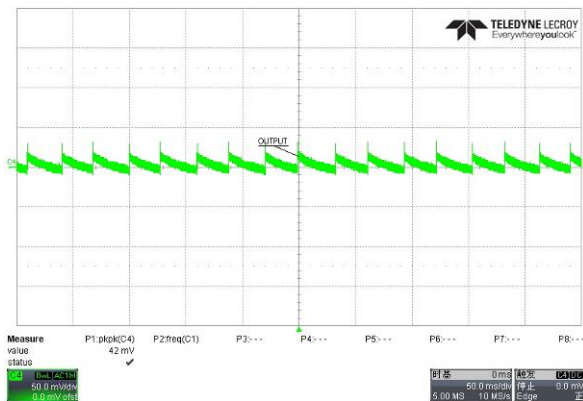

Fig. 3 R&N waveform@264Vac; no load

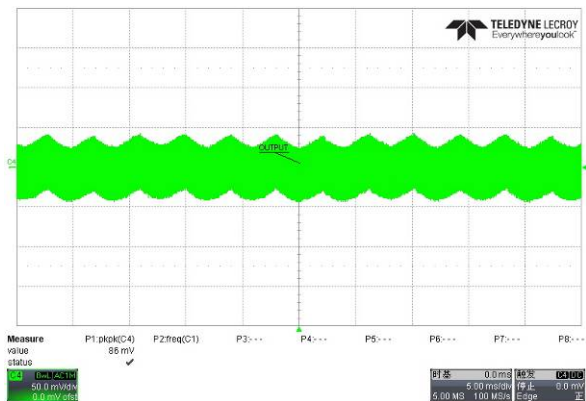

Fig. 4 R&N waveform@264Vac; full load

3.2.3 Overshoot & Undershoot

Ac input switches ON for overshoot and OFF for undershoot

Table 6 Overshoot/undershoot measurement results

Input Voltage	Load	Item	Measure Data (%)	Waveform
90V/60Hz	Full load	overshoot	1.6	Fig.5
		undershoot	2.2	Fig.9
	No load	overshoot	1.6	Fig.6
		undershoot		
264V/50Hz	Full load	overshoot	1.6	Fig.7
		undershoot	2.2	Fig.10
	No load	overshoot	1.6	Fig.8
		undershoot		

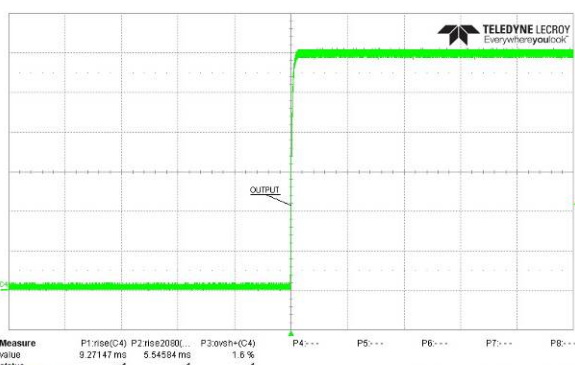

Fig. 5 Overshoot waveform @90Vac; full load

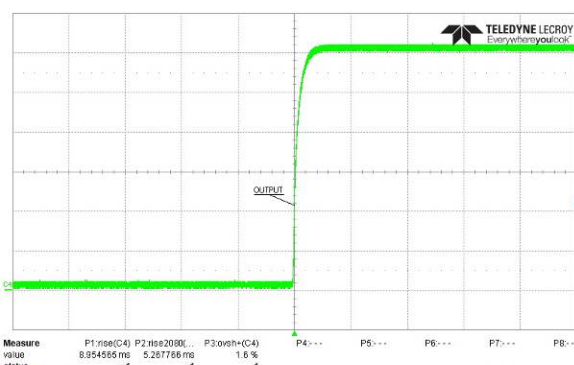

Fig. 6 Overshoot waveform @90Vac; no load

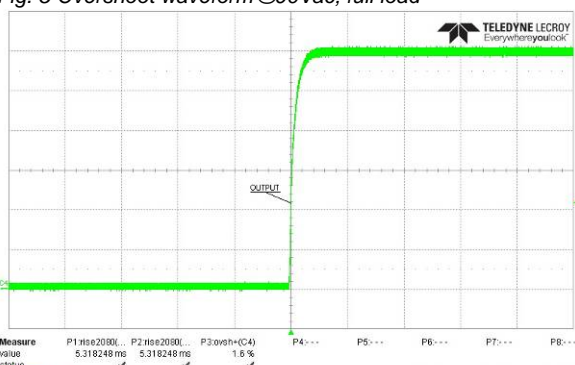

Fig. 7 Overshoot waveform @264Vac; full load

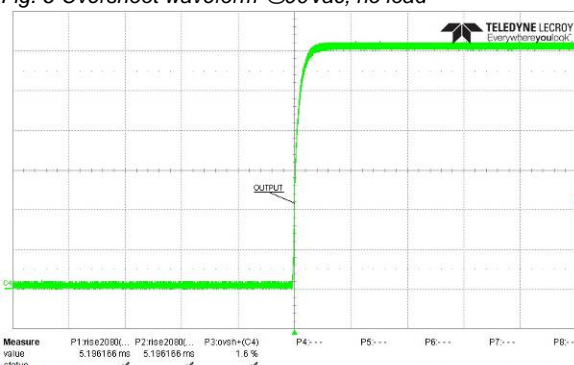

Fig. 8 Overshoot waveform @264Vac; no load

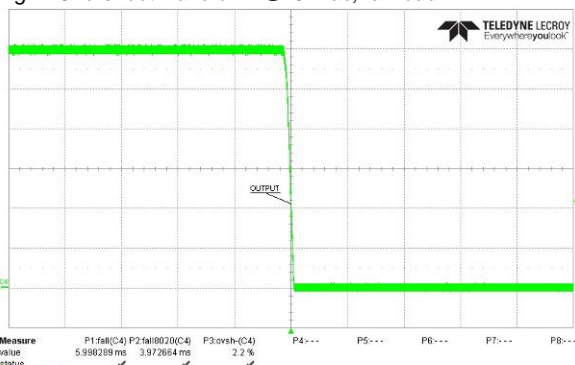

Fig. 9 Undershoot waveform @90Vac; full load

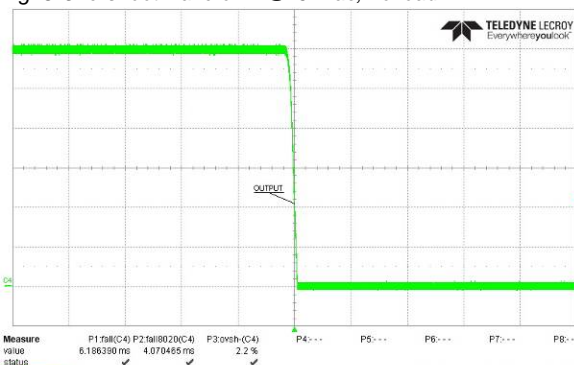

Fig. 10 Undershoot waveform @264Vac; full load

3.2.4 Dynamic Test

A dynamic loading with low set at 10% load lasting for 20mS and high set at 100% load lasting for 20mS is added to output. The ramp is set at 0.25A/uS at transient. All data was measurement at AWG16 1.5M CABLE end.

Table 7 Output voltage under dynamic test

Input voltage	Output voltage (mV)	Waveform
90V/60HZ	± 372	Fig.11
264V/50HZ	± 349	Fig.12

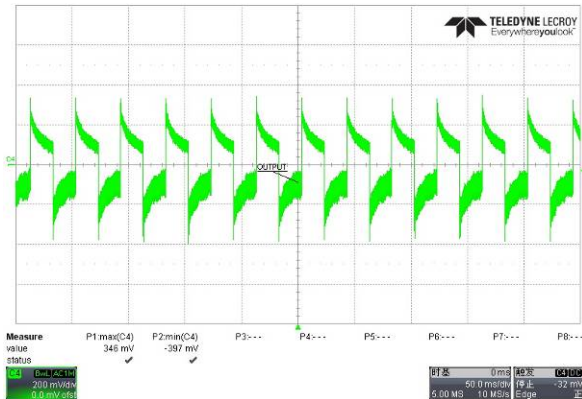

Fig. 11 Dynamic waveform @90Vac input

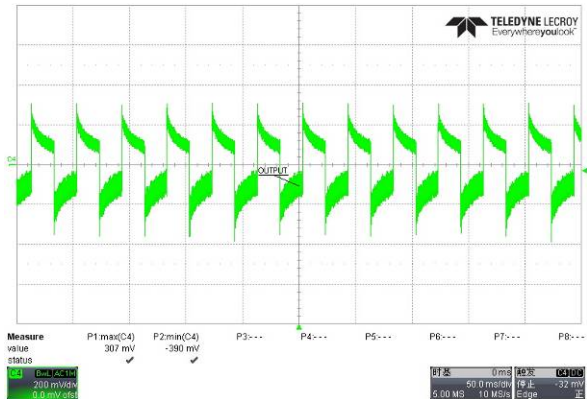

Fig. 12 Dynamic waveform @264Vac input

3.2.5 Time Sequence

Load condition: Full load

Table 8 Turn-on delay /hold-up measurement results

Item	Input voltage	Meas. Data (mS)	Remark
Turn-on delay time	100V/60Hz	1906	Fig.13
Turn-on delay time	240V/50Hz	710	Fig.14
Hold-up time	100V/60Hz	10.13	Fig.15
Hold-up time	240V/50Hz	94.60	Fig.16

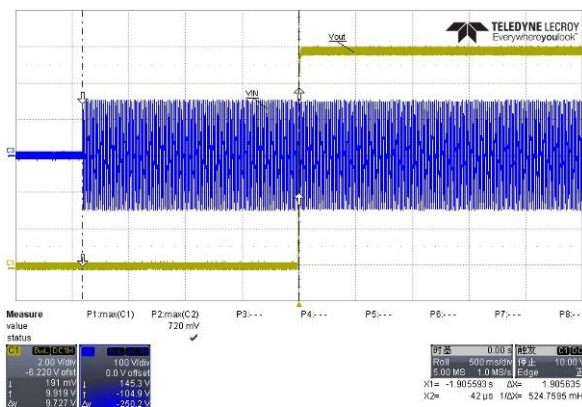

Fig. 13 Turn on delay waveform @90Vac; full load

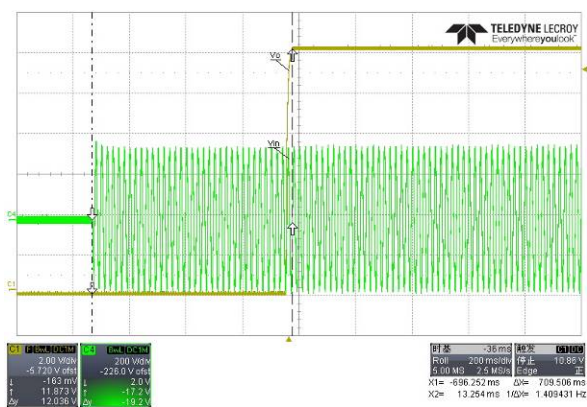

Fig. 14 Turn on delay waveform @240Vac; full load

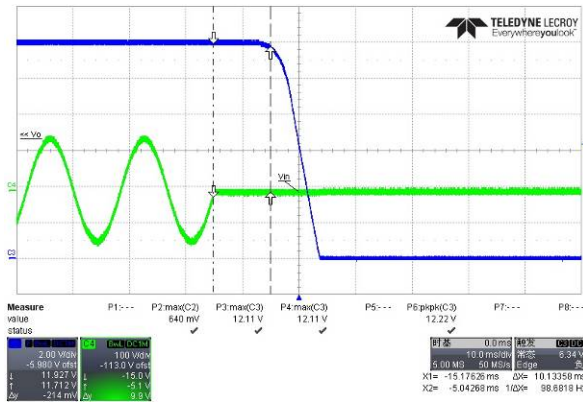

Fig. 15 Hold up time waveform @100Vac; full load

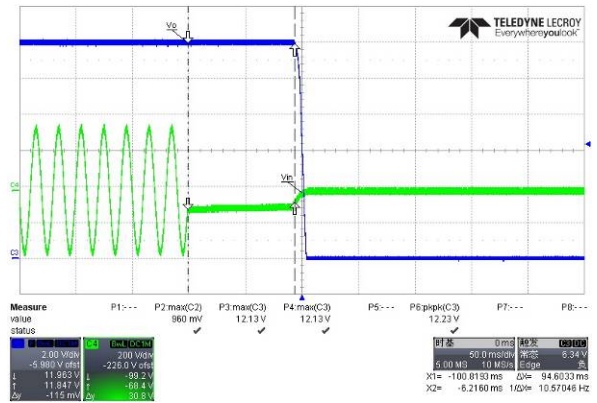

Fig. 16 Hold up time waveform @240Vac; full load

3.3 Protections

3.3.1 Over Current Protection (OCP)

The power supply will shut down with auto-recovery when output current exceeds 5.5A~7.5A, and it should recover when the over current condition is removed.

Table 9 OCP value vs. input voltage

Input Voltage	90V/60Hz	115V/60Hz	230V/50Hz	264V/50Hz
OCP (A)	6.38	6.83	6.76	6.73
Max.Start Up Current(A)	6.36	6.75	6.74	6.70

3.3.2 Over Voltage Protection (OVP)

The power supply will shut down with auto-recovery when feedback circuit is disabled, and the output voltage can not be over 16V, and it should recover when the over voltage condition is removed.

Table 10 Load OVP test result

Input Voltage	OVP Trigger Voltage (V)	
	No Load	
90V/60Hz	14.77V	
264V/50Hz	14.71V	

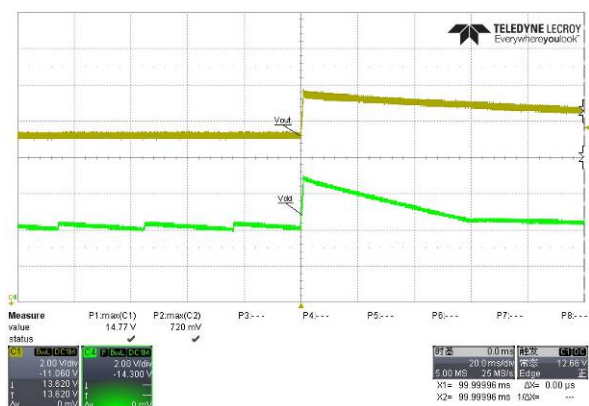

Fig. 17 OVP waveform @90Vac; no load

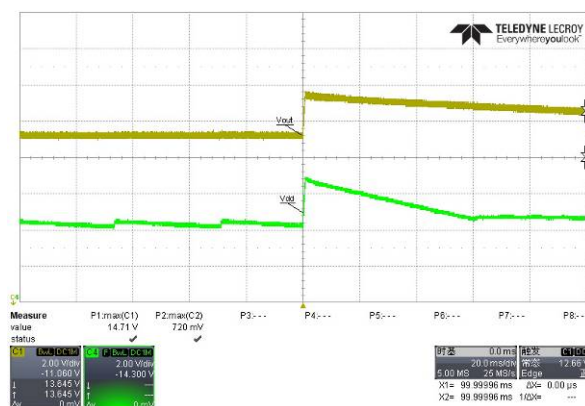

Fig. 18 OVP waveform @264Vac; no load

3.3.3 Over Load Protection (OLP)

The power supply will shut down with auto-recovery when output current exceeds OCP and it should recover when the over current condition is removed.

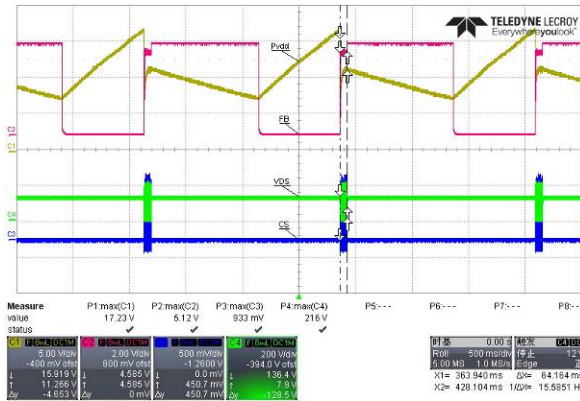

Fig. 19 OLP waveform @90Vac; over load

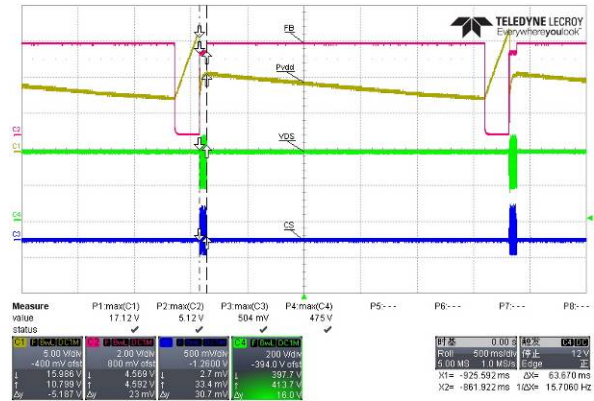

Fig. 20 OLP waveform @264Vac; over load

3.4 Thermal Test

The thermal test is under 40°C ambience after 4hour full load ruining with 90Vac & 264Vac input, inside the box of 60cm*60cm*60cm.

Table 11 Thermal test result

Position	Description	90Vac input	264Vac Input
BD1	GBL406	107.4	76.9
T1	T1(wire)	91.8	79.9
T1	T1(core)	89.8	77.8
U1	IC(OB2365E)	80.4	67.7
U2	IC(OB2004A)	93.6	82.9
Q1	K2843	98.3	79.0
Q2	FDP036N10A	89.4	84.9

Case:132.6(L) x 65.9(W) x 43.2(H)mm

3.5 EMI Test

The Power supply passed EN55022 Class B & FCC class B EMI requirement with more than 6dB margin

3.5.1 Conduction EMI Test

EN55022 CLASS B @ full load report

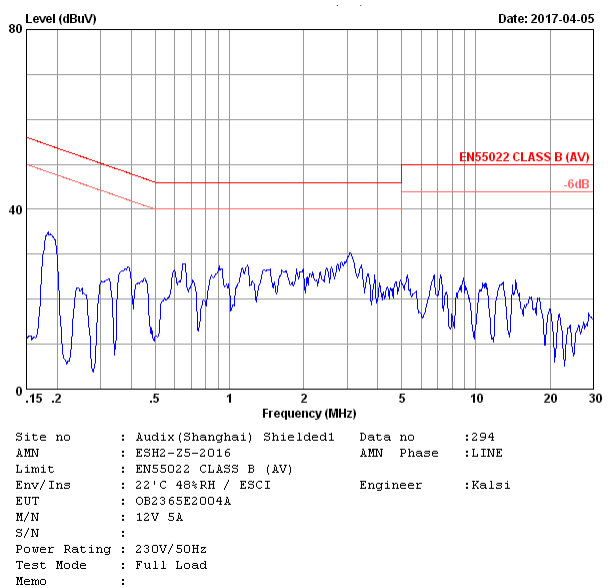
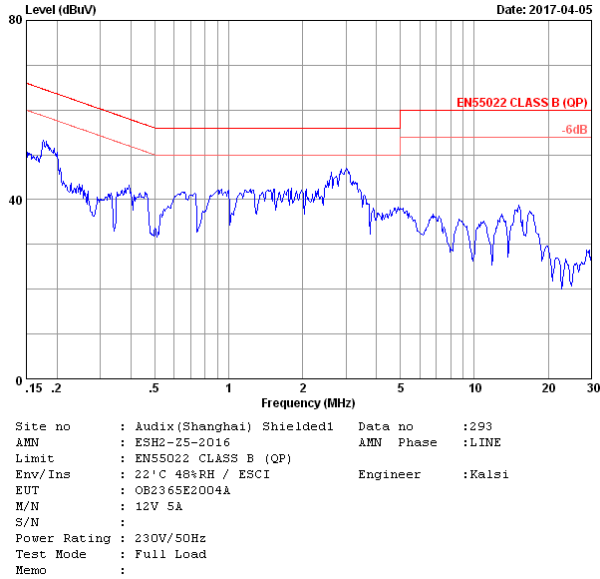
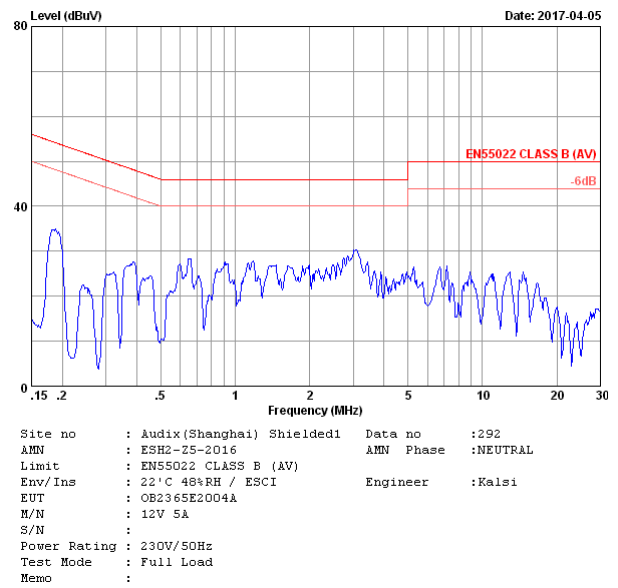
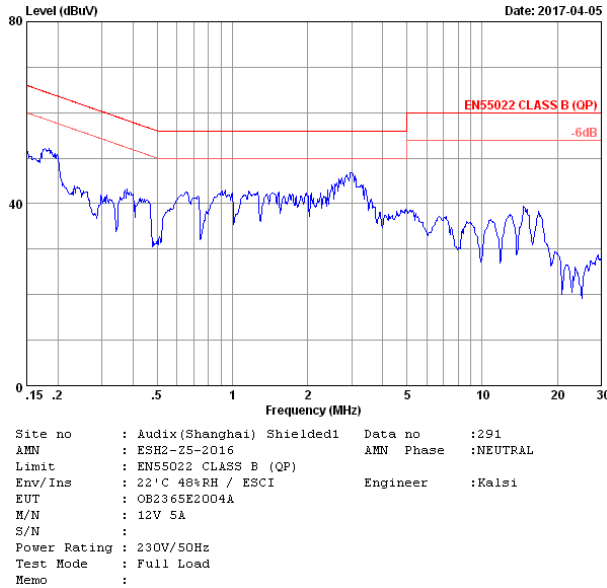

FCC CLASS B @ full load report

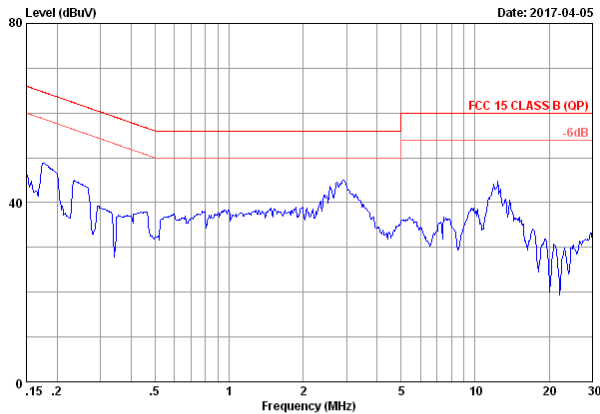

Site no : Audix(Shanghai) Shielded1 Data no :287
 AMN : ESH2-25-2016 AMN Phase :NEUTRAL
 Limit : FCC 15 CLASS B (QP)
 Env/Ins : 22°C 48%RH / ESCI Engineer :Kalsi
 EUT : OB2365E2004A
 M/N : 12V 5A
 S/N :
 Power Rating : 120V/60Hz
 Test Mode : Full Load
 Memo :

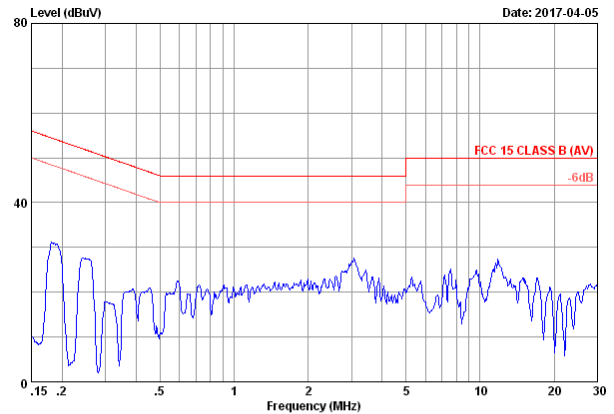

Site no : Audix(Shanghai) Shielded1 Data no :288
 AMN : ESH2-25-2016 AMN Phase :NEUTRAL
 Limit : FCC 15 CLASS B (AV)
 Env/Ins : 22°C 48%RH / ESCI Engineer :Kalsi
 EUT : OB2365E2004A
 M/N : 12V 5A
 S/N :
 Power Rating : 120V/60Hz
 Test Mode : Full Load
 Memo :

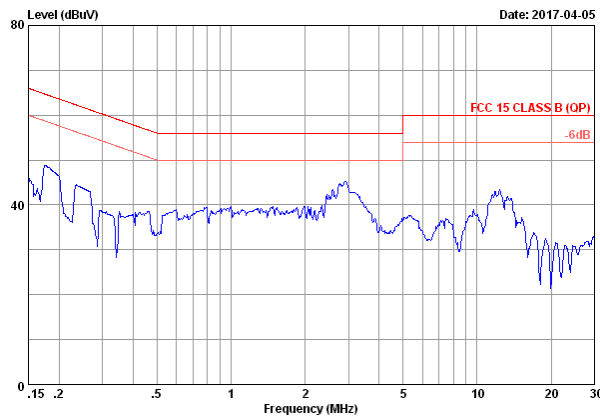

Site no : Audix(Shanghai) Shielded1 Data no :289
 AMN : ESH2-25-2016 AMN Phase :NEUTRAL
 Limit : FCC 15 CLASS B (QP)
 Env/Ins : 22°C 48%RH / ESCI Engineer :Kalsi
 EUT : OB2365E2004A
 M/N : 12V 5A
 S/N :
 Power Rating : 120V/60Hz
 Test Mode : Full Load
 Memo :

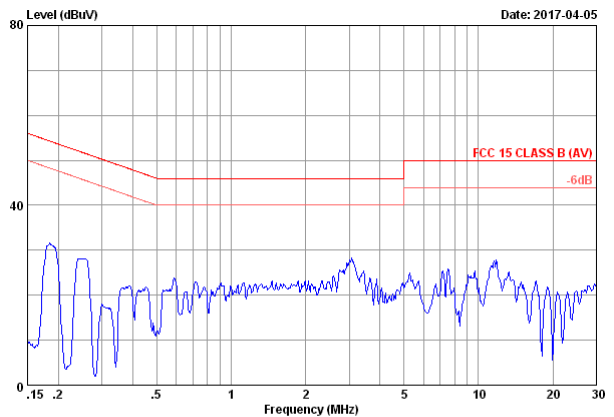

Site no : Audix(Shanghai) Shielded1 Data no :290
 AMN : ESH2-25-2016 AMN Phase :NEUTRAL
 Limit : FCC 15 CLASS B (AV)
 Env/Ins : 22°C 48%RH / ESCI Engineer :Kalsi
 EUT : OB2365E2004A
 M/N : 12V 5A
 S/N :
 Power Rating : 120V/60Hz
 Test Mode : Full Load
 Memo :

3.5.2 Radiation EMI Test

EN55022 CLASS B @ full load report

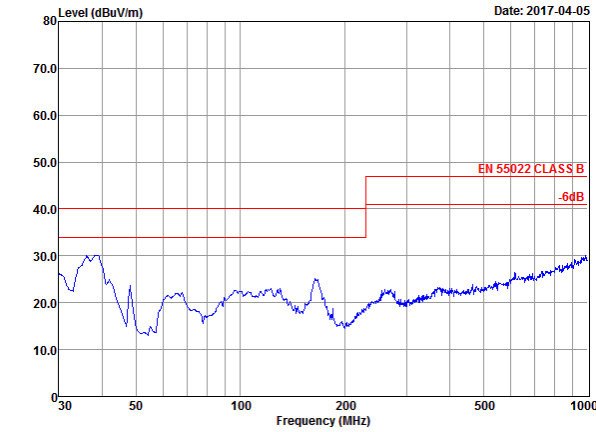

Site : Audix(Shanghai) Chamber3
 Condition : EN 55022 CLASS B VERTICAL
 Project No. :
 Applicant :
 EUT :
 M/N : OB2365E2004A
 S/N :
 Power Supply : 230V/50Hz
 Ambient : 22'C 60%RH
 Test Mode : 12V 5A
 Test Engineer: Sunny
 Memo :

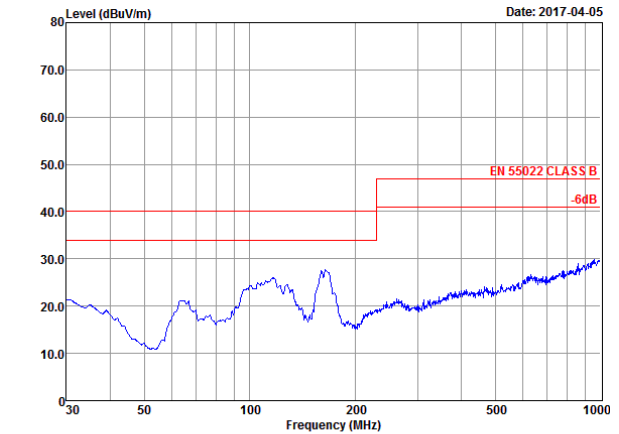

Site : Audix(Shanghai) Chamber3
 Condition : EN 55022 CLASS B HORIZONTAL
 Project No. :
 Applicant :
 EUT :
 M/N : OB2365E2004A
 S/N :
 Power Supply : 230V/50Hz
 Ambient : 22'C 60%RH
 Test Mode : 12V 5A
 Test Engineer: Sunny
 Memo :

FCC CLASS B @ full load report

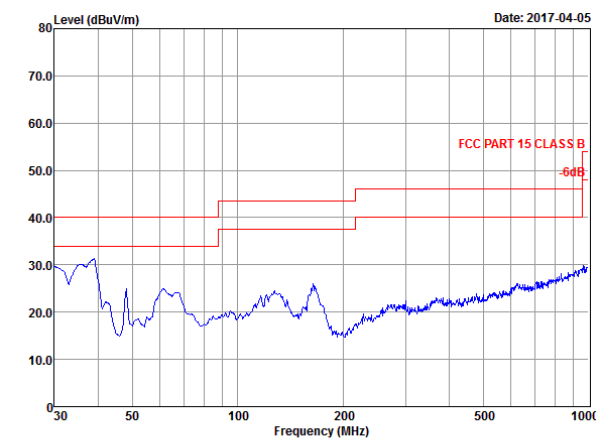

Site : Audix(Shanghai) Chamber3
 Condition : FCC PART 15 CLASS B VERTICAL
 Project No. :
 Applicant :
 EUT :
 M/N : OB2365E2004A
 S/N :
 Power Supply : 120V/60Hz
 Ambient : 22'C 60%RH
 Test Mode : 12V 5A
 Test Engineer: Sunny
 Memo :

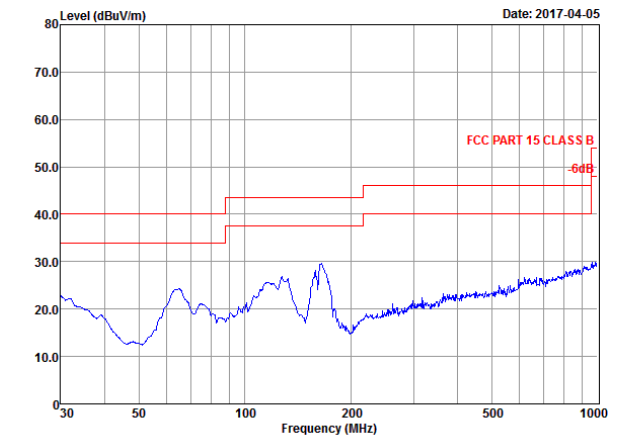

Site : Audix(Shanghai) Chamber3
 Condition : FCC PART 15 CLASS B HORIZONTAL
 Project No. :
 Applicant :
 EUT :
 M/N : OB2365E2004A
 S/N :
 Power Supply : 120V/60Hz
 Ambient : 22'C 60%RH
 Test Mode : 12V 5A
 Test Engineer: Sunny
 Memo :

4 Other important waveform

4.1 CS, FB, Vdd & Vds waveform at no load/full load.

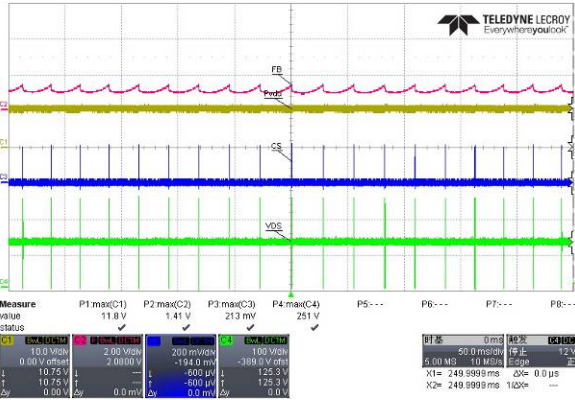

Fig. 21 CS,FB,Vdd&Vds wave form @90Vac; no load

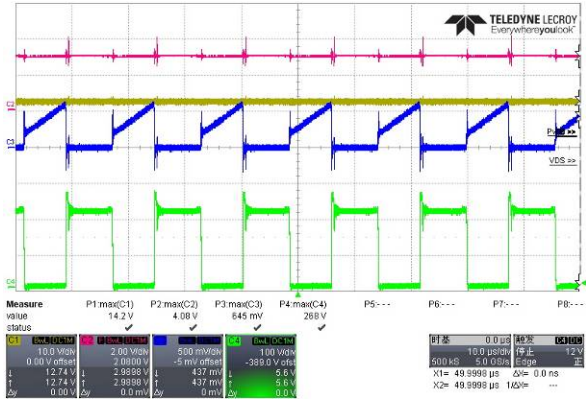

Fig. 22 CS,FB,Vdd&Vds wave form @90Vac; full load

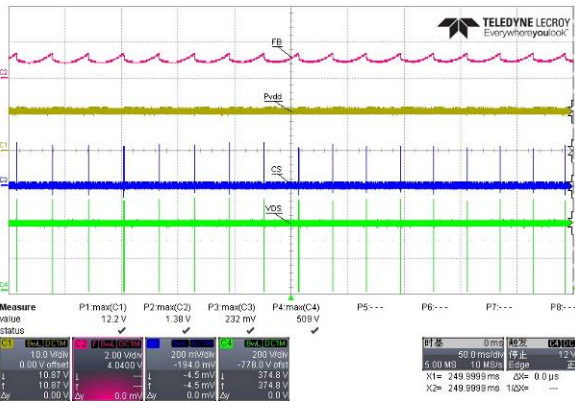

Fig. 23 CS,FB,Vdd&Vds wave form @264Vac; no load

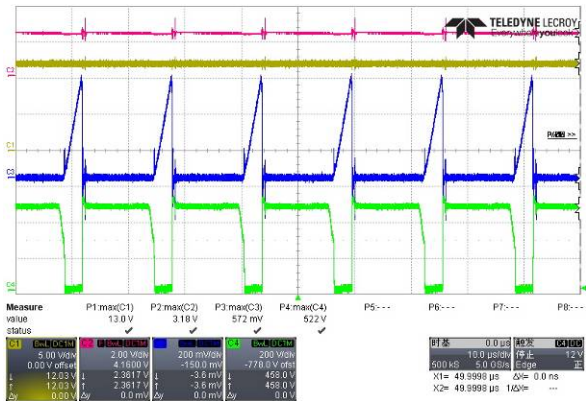

Fig. 24 CS,FB,Vdd&Vds wave form @264Vac; full load

4.2 Synchronous rectification Sgate, Svdd & Vd at no load/full load

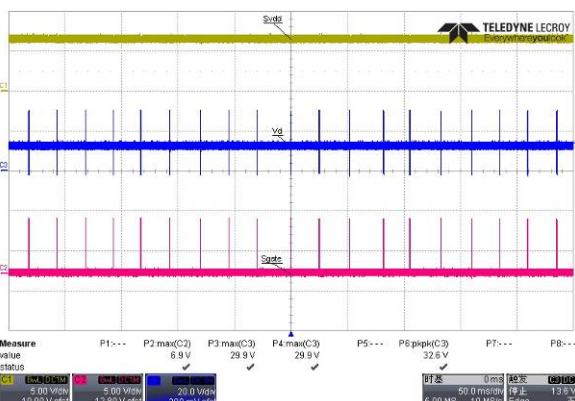

Fig. 25 Synchronous rectification Sgate, Svdd & Vd wave form @90Vac; no load

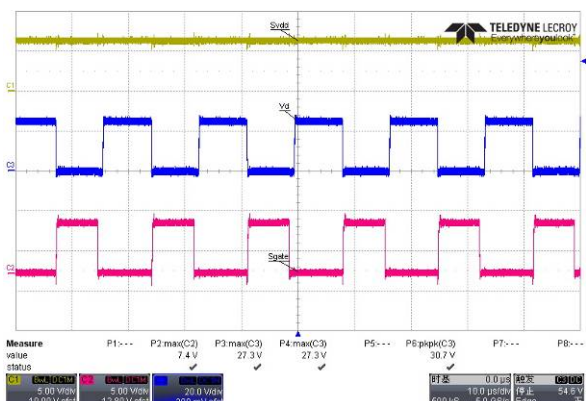

Fig. 26 Synchronous rectification Sgate, Svdd & Vd wave form @90Vac; full load

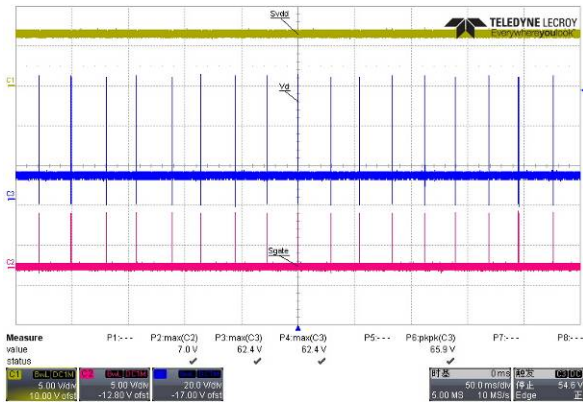

Fig. 27 Synchronous rectification Sgate, Svdd & Vd waveform @264Vac; no load

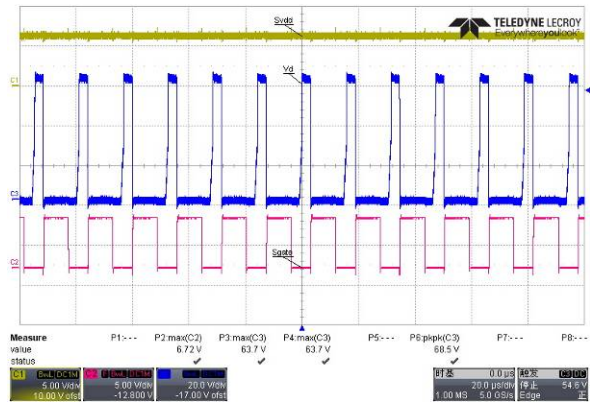

Fig. 28 Synchronous rectification Sgate, Svdd & Vd waveform @264Vac; full load

4.3 Vds waveform at full load, start/normal/output short

4.3.1 Vds at full load, start/normal/output short

MOSFET measurement results

Item	Input voltage	Meas. Data (Vds_max)	Remark
Start Full load	264V/50HZ	550V	Fig. 29
Normal full load	264V/50HZ	546V	Fig. 31
Short work	264V/50HZ	466V	Fig. 33

Synchronous rectification MOSFET measurement results

Item	Input voltage	Meas. Data (Vds_sr_max)	Remark
Start Full load	264V/50HZ	63.2V	Fig. 30
Normal full load	264V/50HZ	62.2V	Fig. 32
Short work	264V/50HZ	57.7V	Fig. 34

4.3.2 Vds, Vds_sr at full load, start waveform

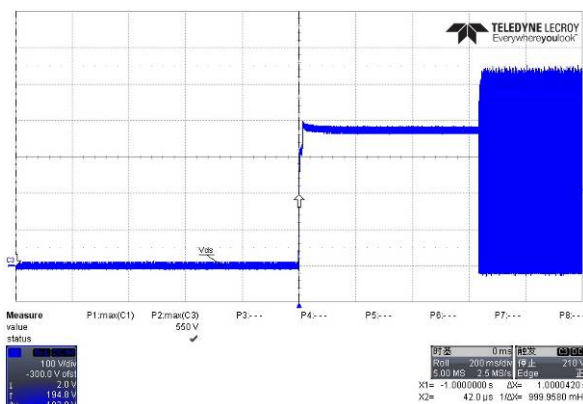

Fig. 29 Vds start up waveform @264Vac; full load

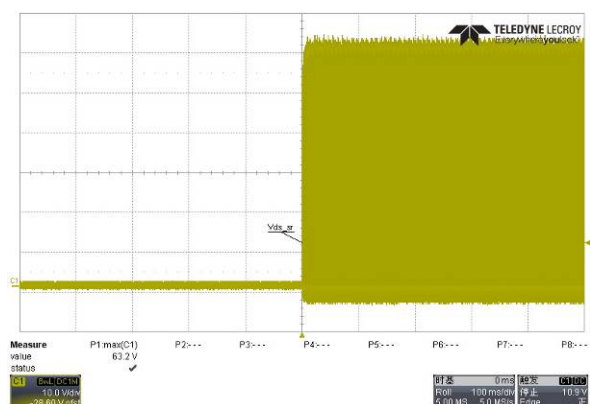

Fig. 30 Vds_sr start up waveform @264Vac; full load

4.3.3 Vds,Vds_sr at full load, normal waveform

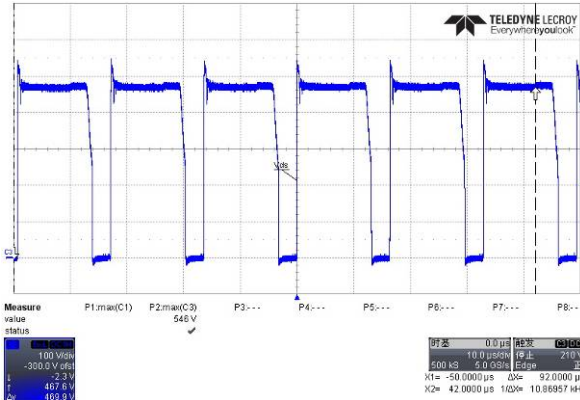

Fig. 31 Vds normal wave form @264Vac; full load

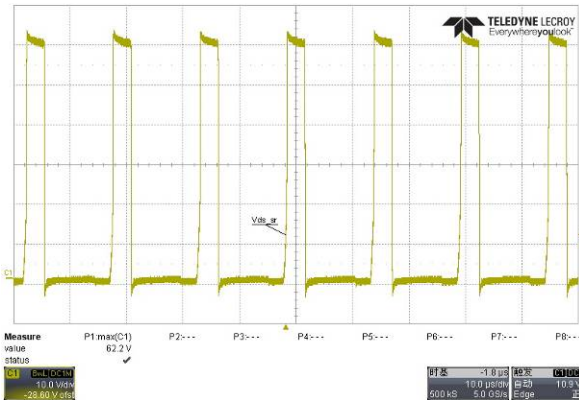

Fig. 32 Vds_sr normal wave form @264Vac; full load

4.3.4 Vds,Vds_sr at full load, output short waveform

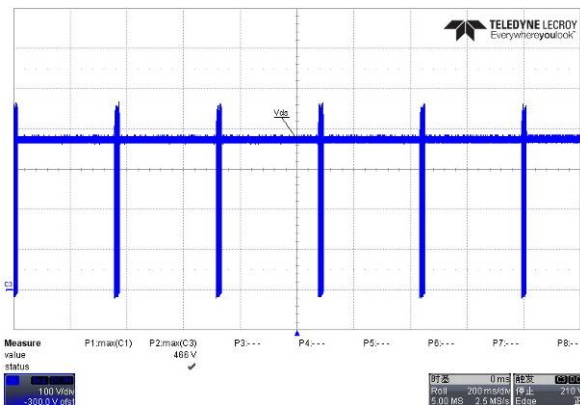

Fig. 33 Vds output short wave form @264Vac; full load

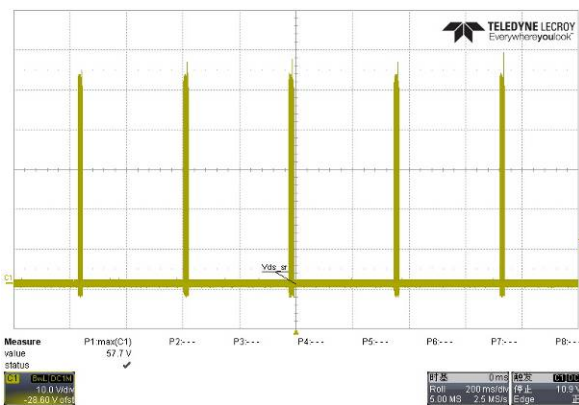

Fig. 34 Vds_sr output short wave form @264Vac; full load

Disclaimer

On-Bright Electronics reserves the right to make corrections, modifications, enhancements, improvements, and other changes to its documents, products and services at any time and to discontinue any product or service without notice. Customers should obtain the latest relevant information before placing orders and should verify that such information is current and complete.

This document is under copy right protection. None of any part of document could be reproduced, modified without prior written approval from On-Bright Electronics.