

GDT Product Specification

BA***N SMD Gas Discharge Tube (4.5×3.2×2.7mm)



1、FEATURES

- Surface Mounting Design UL Certified E232249
- Small Size Design EIA 1812 4.5×3.2×2.7mm
- High Current Handling Capability 1,000A @ 8/20μs
- Low Capacitance and Insertion Loss
- Fast Response and Long Service Life
- Reliable to Protect Electrostatic Surge



2、AVAILABLE PART NUMBER AND ELECTRICAL PARAMETER @ T=25°C RH = 45%-75%

Part Number	DC Breakdown Voltage①	Tolerance	Impulse Spark-over Voltage	Impulse Discharge Current②	Insulation Resistance		C③ (1MHz)
	100V/s④				of Vs	GΩ	
LT-BA071N	70V	±30%	≤ 700V	1,000A	≥1	25V	≤1pF
LT-BA091N	90V	±30%	≤ 700V	1,000A	≥1	50V	≤1pF
LT-BA151N	150V	±30%	≤ 750V	1,000A	≥1	50V	≤1pF
LT-BA201N	200V	±30%	≤ 750V	1,000A	≥1	100V	≤1pF
LT-BA231N	230V	±30%	≤ 750V	1,000A	≥1	100V	≤1pF
LT-BA301N	300V	±30%	≤ 800V	1,000A	≥1	100V	≤1pF
LT-BA351N	350V	±30%	≤ 850V	1,000A	≥1	100V	≤1pF
LT-BA401N	400V	±30%	≤ 900V	1,000A	≥1	100V	≤1pF
LT-BA401N+	400V	340-550	≤ 900V	1,000A	≥1	100V	≤1pF
LT-BA471N	470V	±30%	≤ 950V	1,000A	≥1	250V	≤1pF
LT-BA601N	600V	±30%	≤ 1050V	1,000A	≥1	250V	≤1pF

- ①、The parameters of all are tested by ITU-T K12
- ②、Total Impulse Discharge Current 1,000A @ 8/20μs by IEC 61000-4-5, 10 shots
- ③、The capacitance are tested by 10kHz @ DC= 0.3V
- ④、The V-T waveform of DCBV and IPBV mus lie between the shades.

3、PART NUMBERING SYSTEM

BA XXX N
 (1) (2) (3)

- (1) Langtuo SMD Gas Discharge Tube in 4.5×3.2×2.7 (L×W×H) (mm),
Total Impulse Discharge Current 1,000A @8/20μs
- (2) DC Breakdown Voltage, e.g., 151=15×10¹=150V
- (3) Tolerance is DC Breakdown Voltage, M=+-20%, N=+-30%

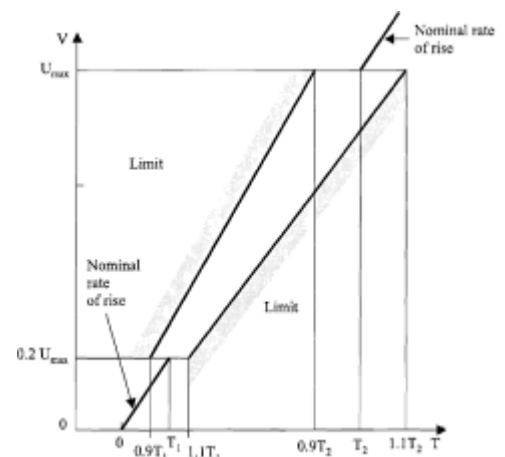

4、DIMENSIONS

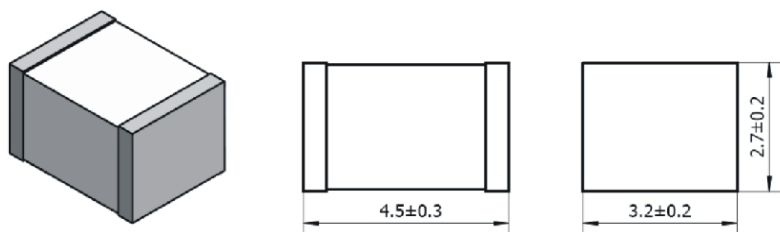

Unit:mm

GDT Product Specification

BA*N SMD Gas Discharge Tube (4.5×3.2×2.7mm)**

5、RECOMMENDED SOLDERING PAD AND REFLOW PROFILE

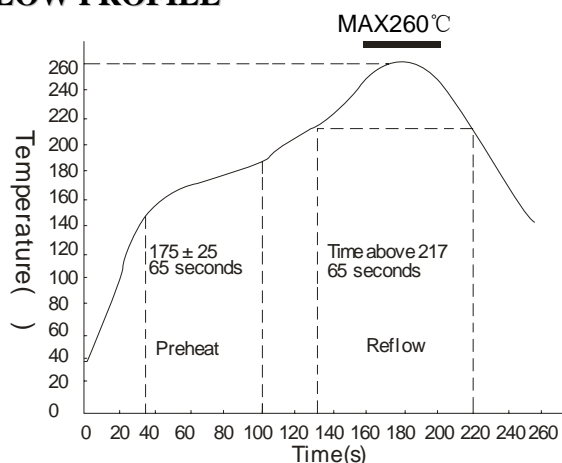
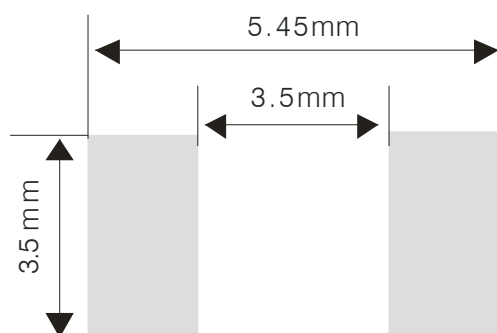

6、PACKAGE REEL INFORMATION

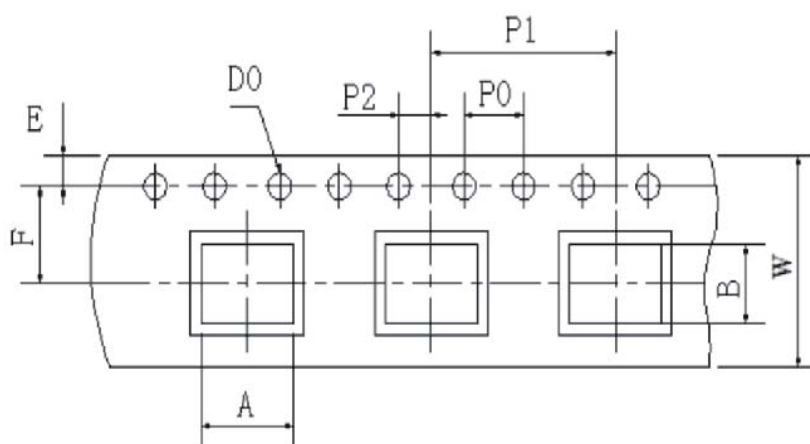

ITEM	DIM(mm)
A	3.7 ± 0.20
B	4.7 ± 0.20
D0	1.50 ± 0.10
E	1.75 ± 0.10
F	5.5 ± 0.10
P0	4.0 ± 0.1
P1	8.0 ± 0.10
P2	2.0 ± 0.1
W	12.0 ± 0.30

OUTLINE	REEL (PCS)	PER CARTON (PCS)	REEL DIAMETERS (mm)	CARTON SIZE(mm)		
				L	W	H
TAPING	2,000	32,000	330	360	360	360

 Remark:
 Special Notes

Date Issued:2009/06