

SC1226K InnoSwitch™ Family



Off-Line CV/CC Flyback Switcher IC with Integrated MOSFET, Sync-Rect and Feedback

Product Highlights

Highly Integrated, Compact Footprint

- Incorporates flyback controller, 650 V MOSFET, secondary-side sensing and synchronous rectification
- Integrated, HIPOT-isolated, feedback link
- Exceptional CV/CC accuracy, independent of transformer design or external components
- Instantaneous transient response $\pm 5\%$ CV with 0-100-0% load step

EcoSmart™ – Energy Efficient

- <10 mW No-load @ 230 VAC with optional bias winding
- Easily meets all global energy efficiency regulations
- Low heat dissipation

Advanced Protection / Safety Features

- Primary sensed output OVP with optional bias winding
- Secondary sensed output overshoot clamp
- Secondary sensed output OCP to zero output voltage
- Hysteretic thermal shutdown

Full Safety and Regulatory Compliance

- 100% production HIPOT compliance testing at 6 kV DC/1 sec
- Reinforced insulation
- Isolation voltage = 3,500 VAC
- UL1577 and TUV (EN60950) safety approved
- EN61000-4-8 (100 A/m) and EN61000-4-9 (1000 A/m) compliant

Green Package

- Halogen free and RoHS compliant

Applications

- Chargers and adapters for smart mobile devices
- LED lighting
- High efficiency, low voltage, high current power supplies

Description

The InnoSwitch family of ICs dramatically simplifies the development and manufacturing of low voltage, high current power supplies, particularly those in compact enclosures or with high efficiency requirements. The InnoSwitch architecture is revolutionary in that the devices incorporate both primary and secondary controllers, with sense elements and a safety-rated feedback mechanism into a single IC.

Close component proximity and innovative use of the integrated communication link permit accurate control of a secondary-side synchronous rectification MOSFET and optimization of primary-side switching to maintain high efficiency across the entire load range. Additionally, the minimal DC bias requirements of the link, enables the system to achieve less than 10 mW no-load in challenging applications such as smart-mobile device chargers.

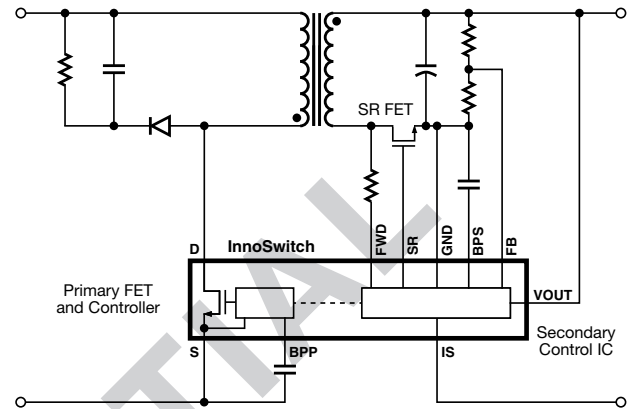

(a) Typical Application Schematic PI-6986-031113

Figure 1. Typical Application/Performance.

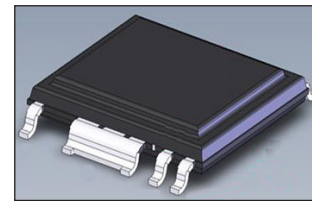

Figure 2. High Creepage, Safety-Compliant eSOP Package.

Output Power Table

Product ³	230 VAC $\pm 15\%$		85-265 VAC	
	Adapter ¹	Peak or Open Frame ²	Adapter ¹	Peak or Open Frame ²
SC1226K	18 W	22 W	18 W	22 W

Table 1. Output Power Table.

Notes:

1. Minimum continuous power in a typical non-ventilated enclosed adapter measured at 40 °C ambient. Assumes +12 V output.
2. Minimum peak power capability.
3. Package: KR: eSOP-R16B.

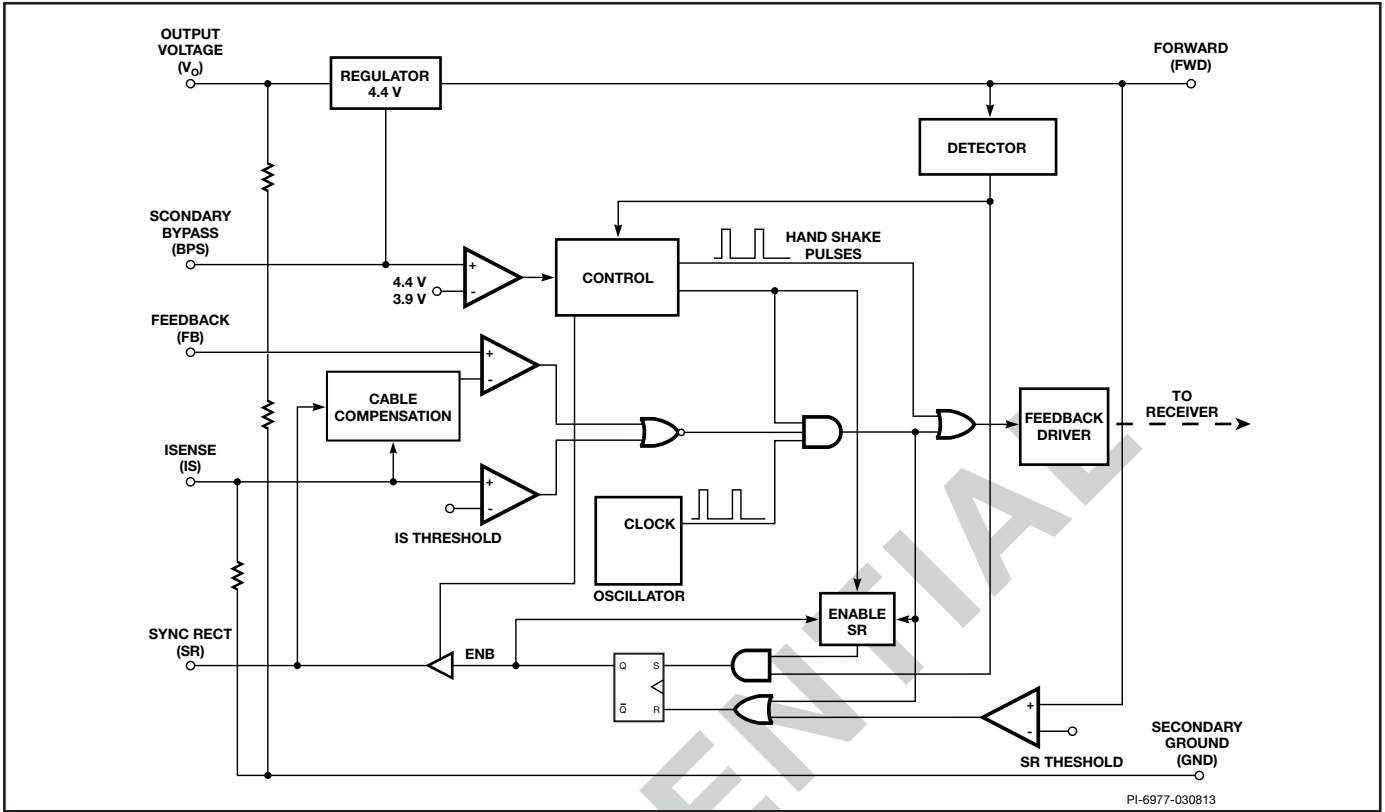

PI-6977-030813

Figure 3. Secondary-Side Controller Block Diagram.

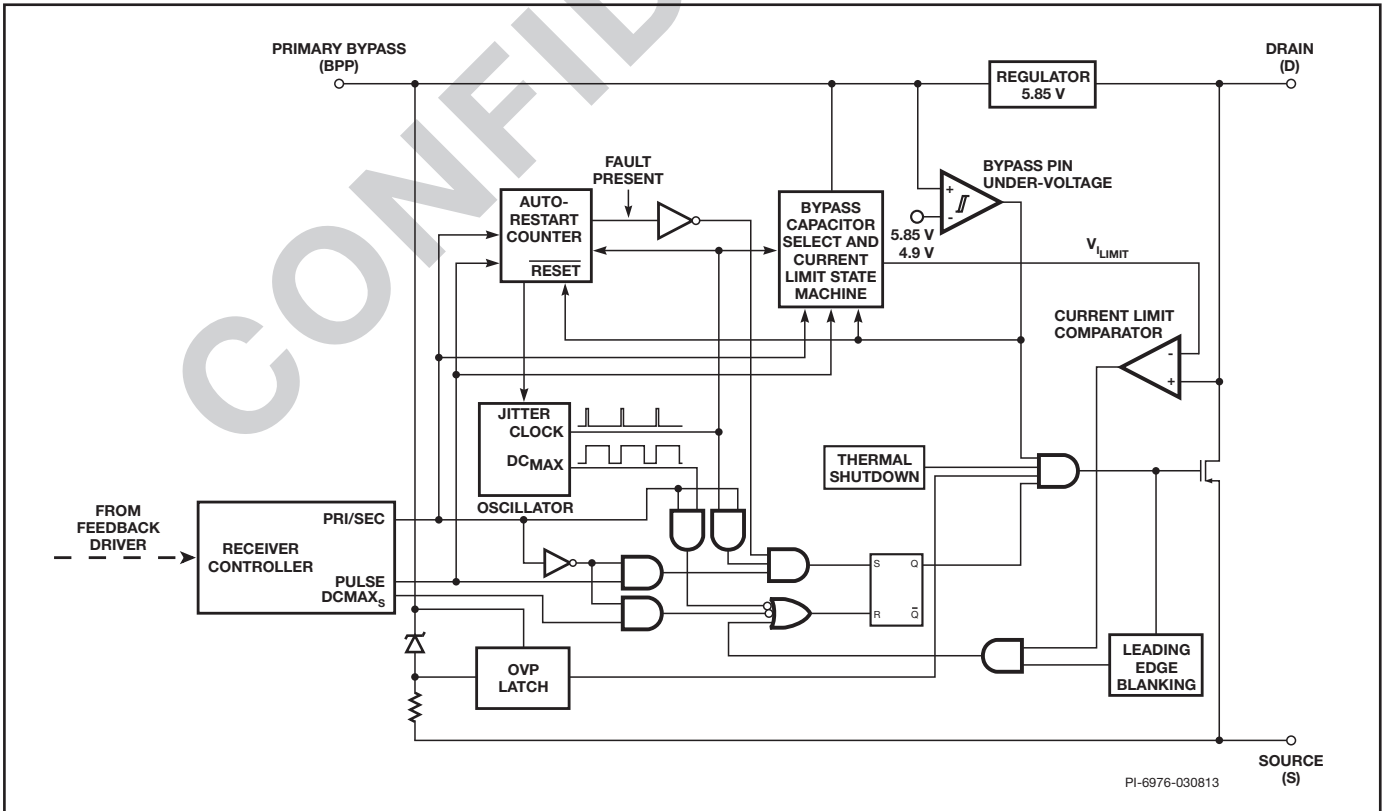

PI-6976-030813

Figure 4. Primary-Side Controller Block Diagram.

Pin Functional Description

Drain (D) Pin: (Pin 1)

This pin is the power MOSFET drain connection.

PRIMARY BYPASS (BPP) Pin: (Pin 7)

It is the connection point for an external bypass capacitor for the primary IC supply.

FEEDBACK (FB) Pin: (Pin 14)

This pin connects to an external resistor divider to set the power supply CV voltage regulation threshold.

FORWARD (FWD) Pin: (Pin 10)

The connection point to the switching node of the transformer output winding for sensing and other functions.

OUTPUT VOLTAGE (VOUT) Pin: (Pin 11)

This pin is connected directly to the output voltage of the power supply to provide bias to the secondary IC.

SYNCHRONOUS RECTIFIER DRIVE (SR) Pin: (Pin 12)

Connection to external SR FET gate terminal.

SECONDARY BYPASS (BPS) Pin: (Pin 13)

It is the connection point for an external bypass capacitor for the secondary IC supply.

SECONDARY GROUND (GND): (Pin 15)

Ground connection for the secondary IC.

ISENSE (IS) Pin: (Pin 16)

Connection to the power supply output terminals. Internal current sense is connected between this pin and the SECONDARY GROUND pin.

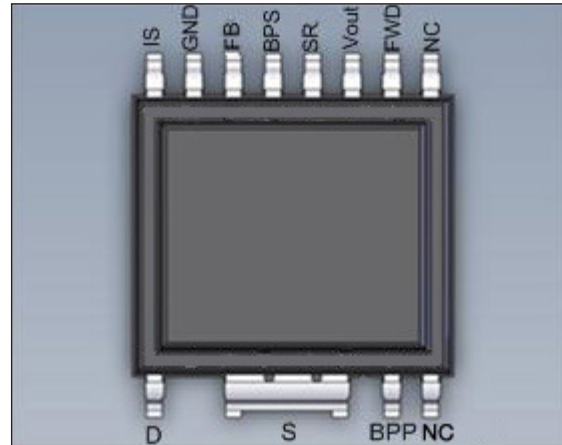

Figure 5. Pin Configuration.

InnoSwitch Operation

InnoSwitch devices operate in the current limit mode. When enabled, the oscillator turns the power MOSFET on at the beginning of each cycle. The MOSFET is turned off when the current ramps up to the current limit or when the DC_{MAX} limit is reached. Since the highest current limit level and frequency of a InnoSwitch design are constant, the power delivered to the load is proportional to the primary inductance of the transformer and peak primary current squared. Hence, designing the supply involves calculating the primary inductance of the

transformer for the maximum output power required. If the InnoSwitch is appropriately chosen for the power level, the current in the calculated inductance will ramp up to current limit before the DC_{MAX} limit is reached.

InnoSwitch senses the output voltage on the FEEDBACK pin using a resistive voltage divider to determine whether or not to proceed with the next switching cycle. The sequence of cycles is used to determine the current limit. Once a cycle is started, it

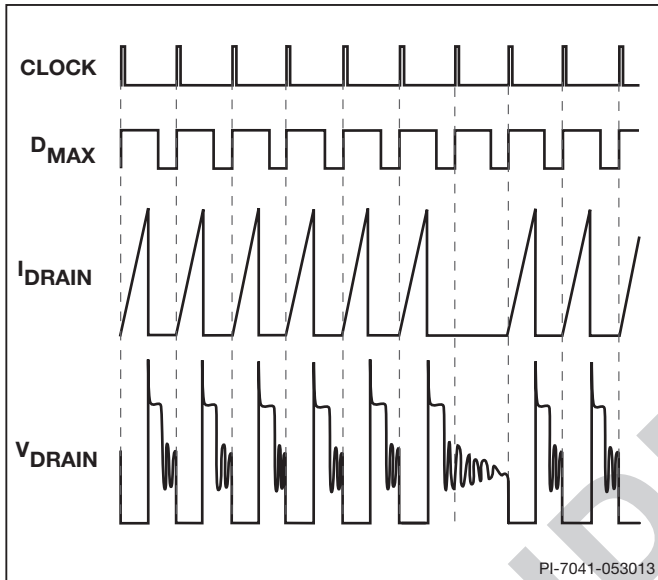

Figure 6. Operation at Near Maximum Loading.

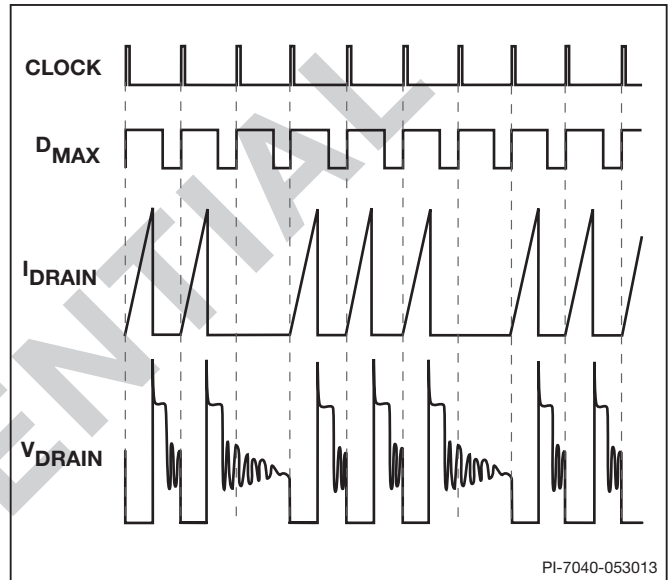

Figure 7. Operation at Moderately Heavy Loading.

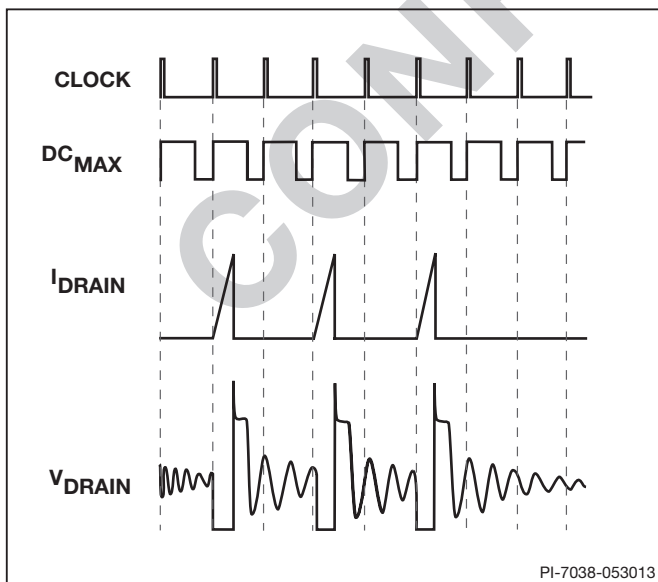

Figure 8. Operation at Medium Loading.

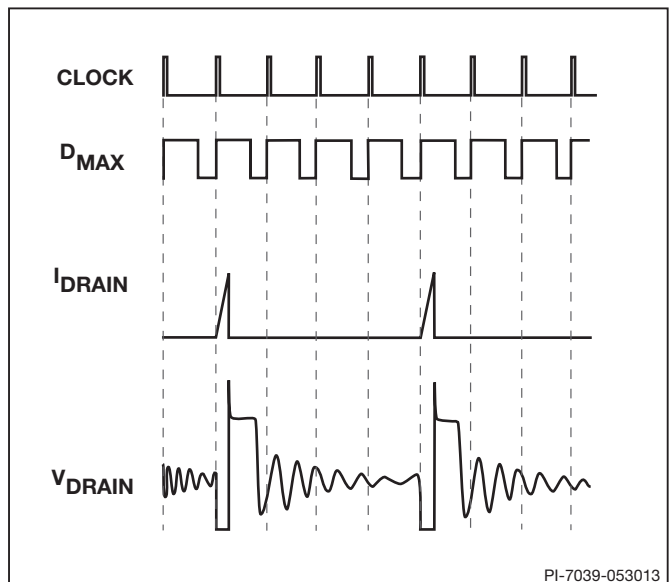

Figure 9. Operation at Very Light Load.

always completes the cycle. This operation results in a power supply in which the output voltage ripple is determined by the output capacitor, and the amount of energy per switch cycle.

ON/OFF Operation with Current Limit State Machine

The internal clock of the InnoSwitch runs all the time. At the beginning of each clock cycle, the voltage comparator on the FEEDBACK pin decides whether or not to implement a switch cycle, and based on the sequence of samples over multiple cycles, it determines the appropriate current limit. At high loads, the state machine sets the current limit to its highest value. At lighter loads, the state machine sets the current limit to reduced values.

At near maximum load, InnoSwitch will conduct during nearly all of its clock cycles (Figure 6). At slightly lower load, it will “skip” additional cycles in order to maintain voltage regulation at the power supply output (Figure 7). At medium loads, cycles will be skipped and the current limit will be reduced (Figure 8). At very light loads, the current limit will be reduced even further (Figure 9). Only a small percentage of cycles will occur to satisfy the power consumption of the power supply.

The response time of the ON/OFF control scheme is very fast compared to PWM control. This provides tight regulation and excellent transient response.

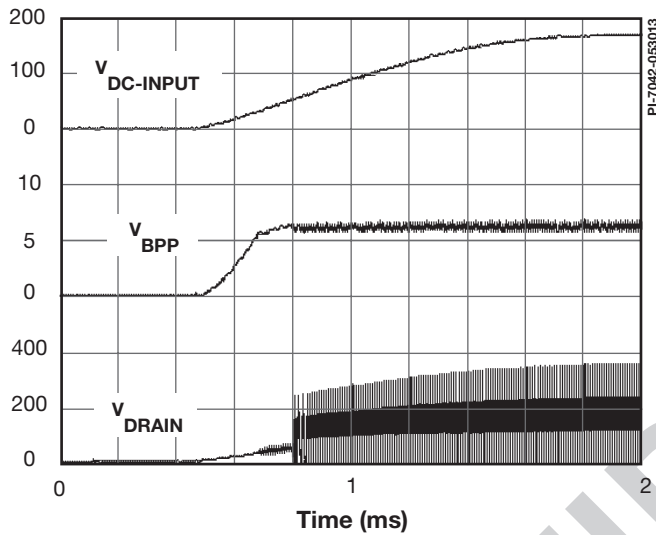

Figure 10. Power-Up.

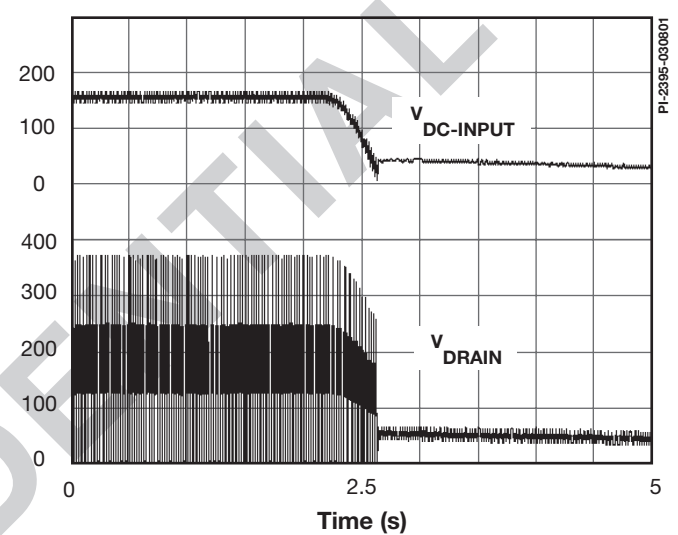

Figure 11. Normal Power-Down Timing.

Absolute Maximum Ratings^{1,2}

DRAIN Pin Voltage	-0.3 V to 650 V	Lead Temperature	260 °C
DRAIN Pin Peak Current	1710 (3200) mA ³	Notes:	
PRIMARY BYPASS/SECONDARY BYPASS Pin Voltage.....	-0.3 V to 9 V	1. All voltages referenced to Source and Secondary Ground, T _A = 25 °C.	
PRIMARY BYPASS/SECONDARY BYPASS Pin Current	100 mA	2. Maximum ratings specified may be applied one at a time without causing permanent damage to the product. Exposure to Absolute Maximum Ratings conditions for extended periods of time may affect product reliability.	
FORWARD Pin Voltage.....	-1.5 V to 70 V	3. Higher peak Drain current is allowed while the Drain voltage is simultaneously less than 400 V.	
FEEDBACK Pin Voltage	-0.3 to 9 V	4. Normally limited by internal circuitry.	
SR/P Pin Voltage	-0.3 to 9 V	5. 1/16" from case for 5 seconds.	
OUTPUT VOLTAGE Pin Voltage.....	-0.3 to 9 V		
Storage Temperature	-65 to 125 °C		
Operating Junction Temperature ⁴	-40 to 125 °C		
Ambient Temperature.....	-40 to 85 °C		

Thermal Resistance

Thermal Resistance: K Package:	Notes:
(θ _{JA}).....65 °C/W ² , 69 °C/W ³	1. Measured on the SOURCE pin close to the plastic interface.
(θ _{JC}).....12 °C/W ²	2. Solder to 0.36 sq. in (232 mm ²), 2 oz. (610 g/m ²) copper clad.
	3. Solder to 1 sq. in (645 mm ²), 2 oz. (610 g/m ²) copper clad.
	4. The case temperature is measured at the bottom-side exposed pad.

Parameter	Conditions	Rating	Units
-----------	------------	--------	-------

Ratings for UL1577 (Adapter power rating is derated power capability)			
Primary-Side Current Rating	Current from pin (3-6) to pin 1	1.5	A
Primary-Side Power Rating	T _{AMB} = 25 °C (Device mounted in socket resulting in T _{CASE} = 120 °C)	1.35	W
Secondary-Side Current Rating	Current from pin 16 to pin 15	2.0	A
Secondary-Side Power Rating	T _{AMB} = 25 °C (Device mounted in socket)	0.125	W

Parameter	Symbol	Conditions SOURCE = 0 V T _{Ji} = -40 °C to +125 °C (Note C) (Unless Otherwise Specified)	Min	Typ	Max	Units

Control Functions						
Output Frequency Applies to Both Primary and Secondary Controllers	f _{OSC}	T _J = 25 °C	Average		100	kHz
			Peak-to-Peak Jitter		8	
Maximum Duty-Cycle	DC _{MAX}		60			%

Parameter	Symbol	Conditions	Min	Typ	Max	Units
		SOURCE = 0 V $T_{Jl} = -40\text{ }^{\circ}\text{C}$ to $+125\text{ }^{\circ}\text{C}$ (Unless Otherwise Specified)				
Control Functions (cont.)						
PRIMARY BYPASS Pin Supply Current	I_{S1}	$V_{BPP} = 6.2\text{ V}$ (MOSFET not Switching) See Note 2		270		μA
	I_{S2}	$T_J = 25\text{ }^{\circ}\text{C}$, $V_{BPP} = 6.2\text{ V}$ (MOSFET Switching at f_{OSC}) See Note 1, 3		990		
PRIMARY BYPASS Pin Charge Current	I_{CH1}	$T_J = 25\text{ }^{\circ}\text{C}$, $V_{BP} = 0\text{ V}$ See Notes 4, 5		-4.7		mA
	I_{CH2}	$T_J = 25\text{ }^{\circ}\text{C}$, $V_{BP} = 4\text{ V}$ See Notes 4, 5		-3.0		
PRIMARY BYPASS Pin Voltage	V_{BPP}	See Note 4		5.95		V
PRIMARY BYPASS Pin Voltage Hysteresis	$V_{BPP(H)}$			0.57		V
PRIMARY BYPASS Shunt Voltage	V_{SHUNT}	$I_{BPP} = 2\text{ mA}$		6.4		V
Circuit Protection						
Standard Current Limit (BPP) Capacitor = $0.1\text{ }\mu\text{F}$	I_{LIMIT} See Note 5	$di/dt = 213\text{ mA}/\mu\text{s}$ $T_J = 25\text{ }^{\circ}\text{C}$	883	950	1102	mA
Reduced Current Limit (BPP) Capacitor = $1\text{ }\mu\text{F}$	$I_{LIMIT-1}$ See Note 5	$di/dt = 213\text{ mA}/\mu\text{s}$ $T_J = 25\text{ }^{\circ}\text{C}$	790	890	918	mA
Increased Current Limit (BPP) Capacitor = $10\text{ }\mu\text{F}$	$I_{LIMIT+1}$ See Note 5	$di/dt = 213\text{ mA}/\mu\text{s}$ $T_J = 25\text{ }^{\circ}\text{C}$	976	1050	1134	mA
Power Coefficient	I^2f	Standard Current Limit $I^2f = I_{LIMIT(TYP)}^2 \times f_{OSC(TYP)}$, $T_J = 25\text{ }^{\circ}\text{C}$	$0.9 \times I^2f$	I^2f	$1.12 \times I^2f$	A^2Hz
		Reduced Current Limit $I^2f = I_{LIMIT-1(TYP)}^2 \times f_{OSC(TYP)}$, $T_J = 25\text{ }^{\circ}\text{C}$	$0.9 \times I^2f$	I^2f	$1.16 \times I^2f$	
		Increased Current Limit $I^2f = I_{LIMIT+1(TYP)}^2 \times f_{OSC(TYP)}$, $T_J = 25\text{ }^{\circ}\text{C}$	$0.9 \times I^2f$	I^2f	$1.16 \times I^2f$	
Initial Current Limit	I_{INIT}	$T_J = 25\text{ }^{\circ}\text{C}$ See Note 1	$0.75 \times I_{LIMIT(TYP)}$			mA
Leading Blank Time	t_{LEB}	$T_J = 25\text{ }^{\circ}\text{C}$ See Note 1	170	250		ns
Current Limit Delay	t_{ILD}	$T_J = 25\text{ }^{\circ}\text{C}$ See Note 1, 6		170		ns
Thermal Shutdown	T_{SD}		135	142	150	$^{\circ}\text{C}$

Parameter	Symbol	Conditions		Min	Typ	Max	Units
		SOURCE = 0 V T _J = -40 °C to +125 °C (Unless Otherwise Specified)					
Circuit Protection (cont.)							
Thermal Shutdown Hysteresis	T _{SD(H)}				75		°C
PRIMARY BYPASS Pin Shutdown Threshold Current	I _{SD}				7.6		mA
Primary Bypass Power-up Reset Threshold Voltage	V _{BPP(RESET)}		T _J = 25 °C		3.0		V
Auto-Restart On-time at f _{osc}	t _{AR}		T _J = 25 °C See Note 7		45		ms
Auto-Restart Trigger Skip Time	t _{AR(SK)}		T _J = 25 °C See Note 7		1		s
Auto-Restart Off-time at f _{osc}	t _{AR(OFF)}		T _J = 25 °C See Note 7		2		s
Output							
ON-State Resistance	R _{DS(ON)}	I _D = 1050 mA	T _J = 25 °C		1.55		Ω
			T _J = 100 °C		2.32		
Off-State Drain Leakage Current	I _{DSS1}		V _{BPP} = 6.2 V V _{DS} = 560 V T _J = 125 °C See Note 8			200	μA
	I _{DSS2}		V _{BPP} = 6.2 V V _{DS} = 325 V T _J = 25 °C See Notes 1, 8		15		μA
Breakdown Voltage	BV _{DSS}		V _{BPP} = 6.2 V T _J = 25 °C See Note 9	650			V
Drain Supply Voltage				50			V

Parameter	Symbol	Conditions		Min	Typ	Max	Units
		SOURCE = 0 V $T_{Jl} = -40\text{ }^{\circ}\text{C}$ to $+125\text{ }^{\circ}\text{C}$ (Unless Otherwise Specified)					
Secondary							
FEEDBACK Pin Voltage	V_{FB}	$T_J = 25\text{ }^{\circ}\text{C}$		1.240	1.265	1.290	V
FEEDBACK Pin Voltage at Turn-Off Voltage	$V_{FB(AR)}$				$0.65 \times V_{FB}$		
Cable Drop Compensation Factor	ϕ_{CD}	$T_J = 25\text{ }^{\circ}\text{C}$			1.06		
SECONDARY BYPASS Pin Current at No-Load	I_{SNL}	$T_J = 25\text{ }^{\circ}\text{C}$				270	μA
SECONDARY BYPASS Pin Voltage	V_{BPS}	$T_J = 25\text{ }^{\circ}\text{C}$			4.44		V
SECONDARY BYPASS Pin Undervoltage Threshold	$V_{BPS(UVLO)}$	$T_J = 25\text{ }^{\circ}\text{C}$			3.85	3.95	V
SECONDARY BYPASS Pin Undervoltage Hysteresis	$V_{BPS(HYS)}$	$T_J = 25\text{ }^{\circ}\text{C}$			0.65		V
Output (IS Pin) Current Limit Voltage Threshold	IS_{VTH}	$T_J = 25\text{ }^{\circ}\text{C}$			33		mV
SR/P Pin Voltage Threshold	V_{SRTH}	$T_J = 25\text{ }^{\circ}\text{C}$			-24		mV
SR/P Pin Pull-Up Current	I_{SRPU}	$T_J = 25\text{ }^{\circ}\text{C}$			165		mA
SR/P Pin Pull-Down Current	I_{SRPD}	$T_J = 25\text{ }^{\circ}\text{C}$			265		mA
Constant-Current Regulation Threshold	I_{CC}	$T_J = 25\text{ }^{\circ}\text{C}$		2.0			A

Notes:

1. This parameter is derived from characterization.
2. I_{S1} is an estimate of device current consumption at no-load, since the operating frequency is so low under these conditions. Total device consumption at no-load is sum of I_{S1} and I_{DSS2} (this does not include secondary losses)
3. Since the output MOSFET is switching, it is difficult to isolate the switching current from the supply current at the Drain. An alternative is to measure the PRIMARY BYPASS pin current at 6.2 V.
4. The PRIMARY BYPASS pin is not intended for sourcing supply current to external circuitry.
5. To ensure correct current limit it is recommended that nominal 0.1 μ F/1 μ F/10 μ F capacitors are used. In addition, the BPP capacitor value tolerance should be equal or better than indicated below across the ambient temperature range of the target application. The minimum and maximum capacitor values are guaranteed by characterization.

Nominal PRIMARY BYPASS Pin Capacitor Value	Tolerance Relative to Nominal Capacitor Value	
	Minimum	Maximum
0.1 μ F	-60%	+100%
1 μ F	-50%	+100%
10 μ F	-50%	N/A

6. This parameter is derived from the change in current limit measured at 1X and 4X of the di/dt shown in the I_{LIMIT} specification.
7. Auto-restart on-time has same temperature characteristics as the oscillator (inversely proportional to frequency).
8. I_{DSS1} is the worst-case OFF state leakage specification at 80% of BV_{DSS} and the maximum operating junction temperature. I_{DSS2} is a typical specification under worst-case application conditions (rectified 265 VAC) for no-load consumption calculations.
9. Breakdown voltage may be checked against minimum BV_{DSS} specification by ramping Drain voltage up to but not exceeding minimum BV_{DSS} .

eSOP-R16B (KR Package)

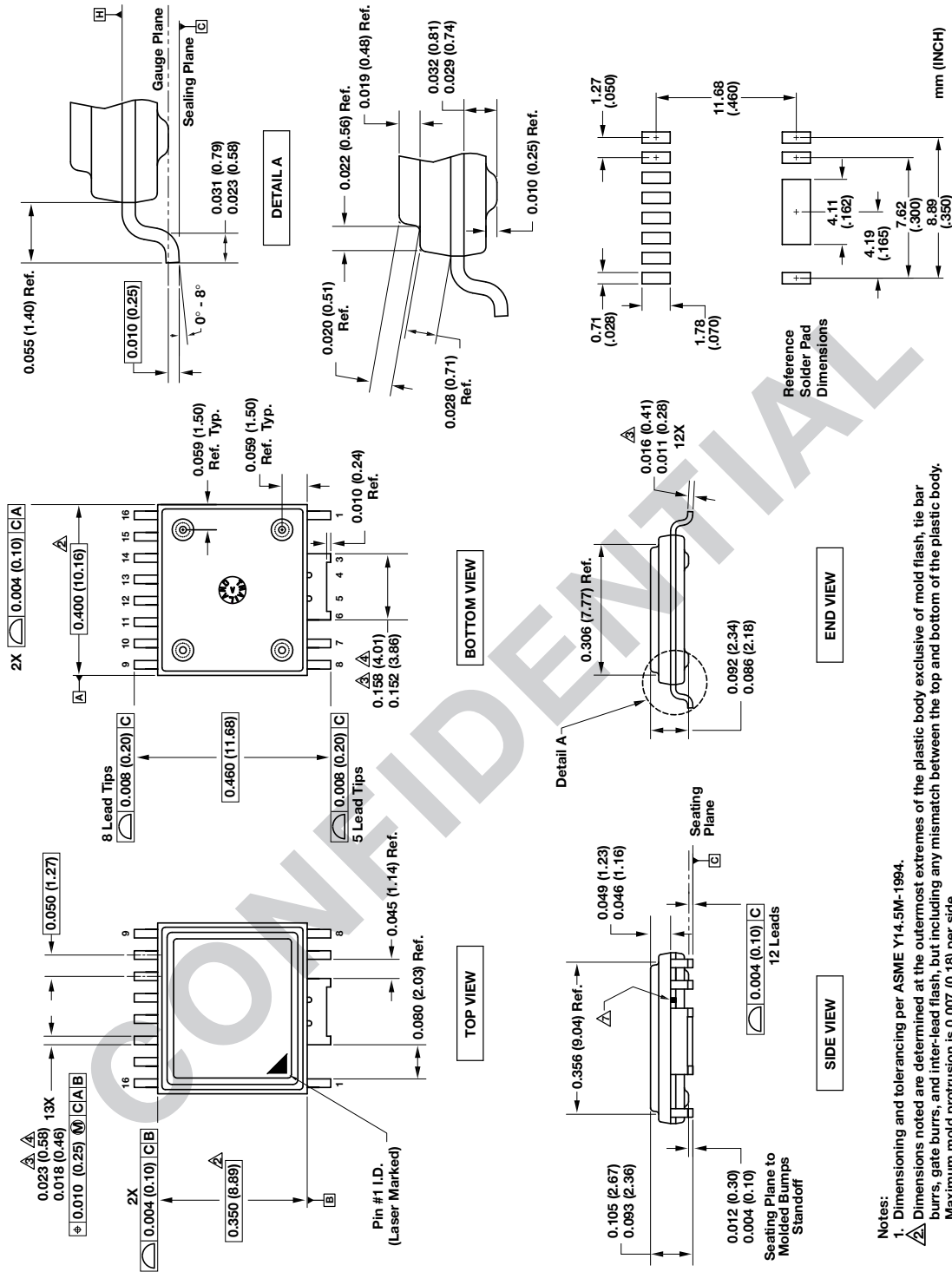

- Notes:
1. Dimensioning and tolerancing per ASME Y14.5M-1994.
 2. Dimensions noted are determined at the outermost extremes of the plastic body exclusive of mold flash, tie bar burrs, gate burrs, and inter-lead flash, but including any mismatch between the top and bottom of the plastic body. Maximum mold protrusion is 0.007 (0.18) per side.
 3. Dimensions noted are inclusive of plating thickness.
 4. Does not include inter-lead flash or protrusions.
 5. Controlling dimensions in inches (mm).
 6. Datums A and B to be determined in Datum H.
 7. Exposed metal at the plastic package body outline/surface between leads 2 and 3, connected internally to lead 2.

PI-6995-021814

Revision	Notes	Date
A	Preliminary	02/14

For the latest updates, visit our website: www.powerint.com

Power Integrations reserves the right to make changes to its products at any time to improve reliability or manufacturability. Power Integrations does not assume any liability arising from the use of any device or circuit described herein. POWER INTEGRATIONS MAKES NO WARRANTY HEREIN AND SPECIFICALLY DISCLAIMS ALL WARRANTIES INCLUDING, WITHOUT LIMITATION, THE IMPLIED WARRANTIES OF MERCHANTABILITY, FITNESS FOR A PARTICULAR PURPOSE, AND NON-INFRINGEMENT OF THIRD PARTY RIGHTS.

Patent Information

The products and applications illustrated herein (including transformer construction and circuits external to the products) may be covered by one or more U.S. and foreign patents, or potentially by pending U.S. and foreign patent applications assigned to Power Integrations. A complete list of Power Integrations patents may be found at www.powerint.com. Power Integrations grants its customers a license under certain patent rights as set forth at <http://www.powerint.com/ip.htm>.

Life Support Policy

POWER INTEGRATIONS PRODUCTS ARE NOT AUTHORIZED FOR USE AS CRITICAL COMPONENTS IN LIFE SUPPORT DEVICES OR SYSTEMS WITHOUT THE EXPRESS WRITTEN APPROVAL OF THE PRESIDENT OF POWER INTEGRATIONS. As used herein:

1. A Life support device or system is one which, (i) is intended for surgical implant into the body, or (ii) supports or sustains life, and (iii) whose failure to perform, when properly used in accordance with instructions for use, can be reasonably expected to result in significant injury or death to the user.
2. A critical component is any component of a life support device or system whose failure to perform can be reasonably expected to cause the failure of the life support device or system, or to affect its safety or effectiveness.

The PI logo, TOPSwitch, TinySwitch, LinkSwitch, LYTSwitch, DPA-Switch, PeakSwitch, CAPZero, SENZero, LinkZero, HiperPFS, HiperTFS, HiperLCS, Qspeed, EcoSmart, Clampless, E-Shield, Filterfuse, StakFET, PI Expert and PI FACTS are trademarks of Power Integrations, Inc. Other trademarks are property of their respective companies. ©2014, Power Integrations, Inc.

Power Integrations Worldwide Sales Support Locations

<p>World Headquarters 5245 Hellyer Avenue San Jose, CA 95138, USA. Main: +1-408-414-9200 Customer Service: Phone: +1-408-414-9665 Fax: +1-408-414-9765 e-mail: usasales@powerint.com</p>	<p>Germany Lindwurmstrasse 114 80337 Munich Germany Phone: +49-895-527-39110 Fax: +49-895-527-39200 e-mail: eurosales@powerint.com</p>	<p>Japan Kosei Dai-3 Bldg. 2-12-11, Shin-Yokohama, Kohoku-ku Yokohama-shi Kanagwan 222-0033 Japan Phone: +81-45-471-1021 Fax: +81-45-471-3717 e-mail: japansales@powerint.com</p>	<p>Taiwan 5F, No. 318, Nei Hu Rd., Sec. 1 Nei Hu Dist. Taipei 11493, Taiwan R.O.C. Phone: +886-2-2659-4570 Fax: +886-2-2659-4550 e-mail: taiwansales@powerint.com</p>
<p>China (Shanghai) Rm 2410, Charity Plaza, No. 88 North Caoxi Road Shanghai, PRC 200030 Phone: +86-21-6354-6323 Fax: +86-21-6354-6325 e-mail: chinasales@powerint.com</p>	<p>India #1, 14th Main Road Vasanthanagar Bangalore-560052 India Phone: +91-80-4113-8020 Fax: +91-80-4113-8023 e-mail: indiasales@powerint.com</p>	<p>Korea RM 602, 6FL Korea City Air Terminal B/D, 159-6 Samsung-Dong, Kangnam-Gu, Seoul, 135-728, Korea Phone: +82-2-2016-6610 Fax: +82-2-2016-6630 e-mail: koreasales@powerint.com</p>	<p>Europe HQ 1st Floor, St. James's House East Street, Farnham Surrey GU9 7TJ United Kingdom Phone: +44 (0) 1252-730-141 Fax: +44 (0) 1252-727-689 e-mail: eurosales@powerint.com</p>
<p>China (ShenZhen) 3rd Floor, Block A, Zhongtuo International Business Center, No. 1061, Xiang Mei Rd, FuTian District, ShenZhen, China, 518040 Phone: +86-755-8379-3243 Fax: +86-755-8379-5828 e-mail: chinasales@powerint.com</p>	<p>Italy Via Milanese 20, 3rd. Fl. 20099 Sesto San Giovanni (MI) Italy Phone: +39-024-550-8701 Fax: +39-028-928-6009 e-mail: eurosales@powerint.com</p>	<p>Singapore 51 Newton Road #19-01/05 Goldhill Plaza Singapore, 308900 Phone: +65-6358-2160 Fax: +65-6358-2015 e-mail: singaporesales@powerint.com</p>	<p>Applications Hotline World Wide +1-408-414-9660</p> <p>Applications Fax World Wide +1-408-414-9760</p>