

TAS2557 具有 H 类升压和扬声器感应功能的 5.7W D 类单声道音频放大器

1 特性

- 超低噪声、单声道升压 D 类放大器
 - 在 4Ω 负载和 4.2V 电源电压条件下, THD+N 为 1% 时的功率为 5.7W, THD+N 为 10% 时的功率为 6.9W
 - 在 8Ω 负载和 4.2V 电源电压条件下, THD+N 为 1% 时的功率为 3.8W, THD+N 为 10% 时的功率为 4.5W
- 数模转换器 (DAC) + D 类放大器的输出噪声 (ICN) 为 15.9μV
- 1% THD+N/8Ω 条件下的 DAC + D 类放大器的信噪比 (SNR) 为 111dB
- 1W/8Ω 条件下的 THD+N 为 -90dB (具有平坦频率响应)
- 后置滤波器反馈 (PFFB)
- 当频率为 217Hz 时, 200 mV_{pp} 纹波电压的电源抑制比 (PSRR) 为 110dB
- 输入采样速率范围为 8kHz 至 96kHz
- 内置扬声器感测
 - 测量扬声器电流和电压
 - 测量 VBAT 电压和芯片温度
- 通过专用实时双核数字信号处理器 (DSP) 提供扬声器保护
 - 热量和偏移保护
 - 检测扬声器漏音和受损情况
- 具有多级跟踪功能的高效 H 类升压转换器
 - 500mW、8Ω、3.6V V_{BAT} 时的效率为 86%
 - 700mW、8Ω、4.2V V_{BAT} 时的效率为 87%
- 可配置自动增益控制 (AGC)
 - 限制电池电流消耗
- 可调节 D 类开关边缘速率控制
- 过热保护、短路保护和欠压保护
- I²S、左对齐、右对齐、DSP 以及 TDM 输入和输出接口、
- 适用于寄存器控制的 I²C 或串行外设接口 (SPI)
- 可使用两个 TAS2557 器件实现立体声配置
- 电源
 - 升压输入: 2.9V 至 5.5V
 - 模拟/数字: 1.65V 至 1.95V
 - 数字 I/O: 1.62V 至 3.6V
- 42 焊球、间距为 0.5mm 的 DSBGA 封装

2 应用

- 移动电话和平板电脑
- 视频门铃和具备语音功能的恒温器
- 个人计算机
- 蓝牙扬声器及配件

3 说明

TAS2557 器件是一款先进的 D 类音频放大器, 也是一套功能完备的片上系统 (SoC)。该器件具有超低噪声音频 DAC 以及具备扬声器电压和电流感测反馈的 D 类功率放大器。片上低延迟 DSP 支持德州仪器 (TI) 的 SmartAmp 扬声器保护算法, 能够在维持扬声器处于安全状态的同时, 最大限度提高扬声器的音量。

该器件可通过 I2S 输出轻松与任何处理器搭配使用, 而且使用两个 TAS2557 器件时能够实现立体声。该器件可针对不同的扬声器单独进行调试, 这使得客户能够在保持原有外形尺寸设计的基础上增添产品价值。此外, 无论在哪种工作模式下, TAS2557 均能以 15.9μV 超低 ICN 对语音和音频单独进行动态调试, 从而使得接收器/扬声器的实现成为可能。

器件信息⁽¹⁾

器件型号	封装	封装尺寸 (标称值)
TAS2557	DSBGA (42)	3.47mm x 3.23mm

(1) 要了解所有可用封装, 请参见数据表末尾的可订购产品附录。

简化电路原理图

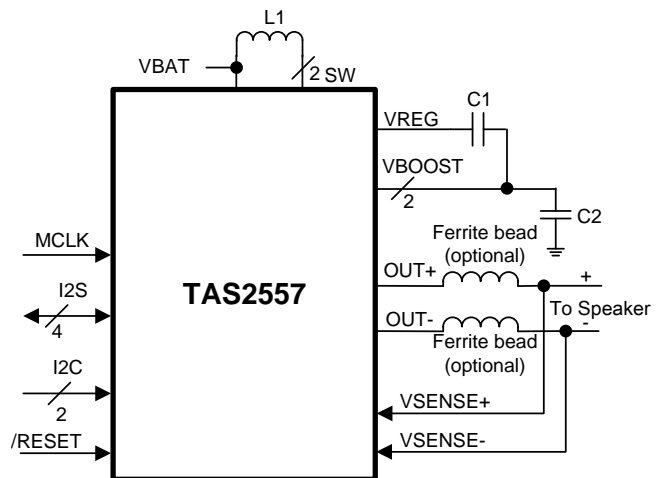

目录

1	特性	1	10.3	Feature Description.....	19
2	应用	1	10.4	Device Functional Modes.....	28
3	说明	1	10.5	Operational Modes.....	36
4	修订历史记录	2	10.6	Programming.....	38
5	说明 (续)	3	11	Applications and Implementation.....	42
6	Device Comparison Table.....	4	11.1	Application Information.....	42
7	Pin Configuration and Functions	5	11.2	Typical Applications	42
8	Specifications.....	7	11.3	Initialization Set Up	44
8.1	Absolute Maximum Ratings	7	12	Power Supply Recommendations	45
8.2	ESD Ratings.....	7	12.1	Power Supplies	45
8.3	Recommended Operating Conditions.....	7	12.2	Power Supply Sequencing.....	45
8.4	Thermal Information	7	13	Layout.....	46
8.5	Electrical Characteristics.....	8	13.1	Layout Guidelines	46
8.6	I ² C Timing Requirements	10	13.2	Layout Example	47
8.7	SPI Timing Requirements	10	14	Register Map.....	48
8.8	I ² S/LJF/RJF Timing in Master Mode	11	14.1	Register Map Summary	48
8.9	I ² S/LJF/RJF Timing in Slave Mode	11	14.2	Register Maps.....	51
8.10	DSP Timing in Master Mode	12	15	器件和文档支持	105
8.11	DSP Timing in Slave Mode	12	15.1	文档支持	105
8.12	Typical Characteristics	15	15.2	社区资源	105
9	Parameter Measurement Information	17	15.3	商标.....	105
10	Detailed Description	18	15.4	静电放电警告.....	105
10.1	Overview	18	15.5	Glossary	105
10.2	Functional Block Diagram	19	16	机械、封装和可订购信息.....	105
			16.1	封装尺寸	105

4 修订历史记录

注：之前版本的页码可能与当前版本有所不同。

Changes from Original (November 2016) to Revision A	Page
• Changed ESD HBM rating from ± 2500 to ± 3500	7
• Changed Power Consumption values	9
• Fixed incorrect part number.....	29

5 说明 (续)

H 类升压转换器生成 D 类放大器电源轨。如果音频信号仅需要较低的 D 类输出功率，则该升压转换器会通过禁用 V_{BAT} 并将其直接连接至 D 类放大器电源来提高系统效率。当需要较高的音频输出功率时，多级升压功能会迅速激活信号跟踪，从而为负载提供额外的电压。

6 Device Comparison Table

PART NUMBER	CONTROL METHOD	Boost Voltage	SNR ⁽¹⁾	ICN	THD+N	Boost Control	Smart Amp Digital Engine
TAS2552	I ² C	8.5 V	94 dB	130 μV	-64 dB	Class-G	NO (External Processing Required)
TAS2553	I ² C	7.5 V	94 dB	130 μV	-64 dB	Class-G	NO (External Processing Required)
TAS2555	I ² C or SPI	8.5 V	111 dB	15.9 μV	-90 dB	Class-H	YES (Processing on Chip)
TAS2557	I ² C or SPI	8.5 V	111 dB	15.9 μV	-90 dB	Class-H	YES (Processing on Chip)
TAS2559	I ² C or SPI	8.5 V	111 dB	15.9 μV	-90 dB	Class-H	YES (Processing on Chip)
TAS2560	I ² C	8.5 V	111 dB	16.2 μV	-88 dB	Class-H	NO (External Processing Required)

(1) A-weighted data.

7 Pin Configuration and Functions

**42-Ball DSBGA
YZ Package
(Top View)**

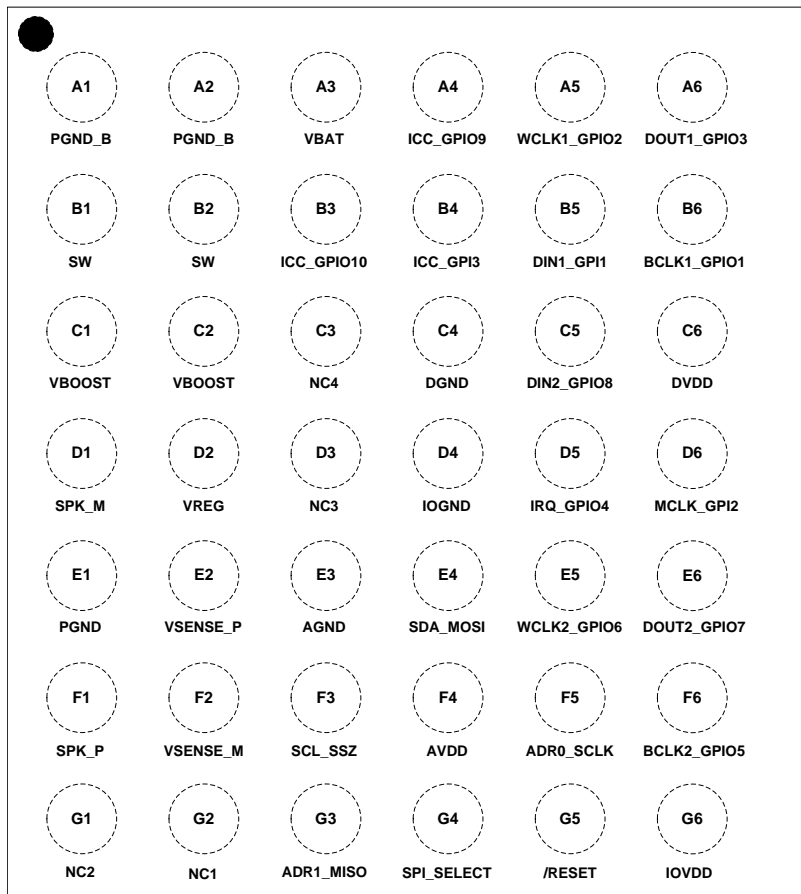

Pin Functions

PIN		TYPE	DESCRIPTION
NAME	BALL NO.		
PGND_B	A1,A2	P	Power ground - connect to high current ground plane.
VBAT	A3	P	Battery power supply - connect to 2.9 V to 5.5 V battery supply.
ICC_GPIO9	A4	I/O	Stereo inter-chip communication clock or GPIO pin.
WCLK1_GPIO2	A5	I/O	Audio word clock on ASI#1 or GPIO pin.
DOUT1_GPIO3	A6	I/O	Audio data output on ASI#1 or GPIO pin.
SW	B1,B2	P	Boost converter switch input .
ICC_GPIO10	B3	I/O	Stereo inter-chip communication data output or GPIO pin.
ICC_GPI3	B4	I	Stereo inter-chip communication data input or GPI pin.
DIN1_GPI1	B5	I	Audio data input to ASI #1 or GPI pin.
BCLK1_GPIO1	B6	I/O	Audio bit clock on ASI#1 or GPIO pin.
VBOOST	C1,C2	P	Boost converter output.
NC4	C3	-	Float connection - do not route any signal or supply to or through this pin.
DGND	C4	P	Digital ground pin.
DIN2_GPIO8	C5	I/O	Audio data input to ASI #2 or GPIO pin.
DVDD	C6	P	1.8V digital power supply for digital core logic.
SPK_M	D1	O	Inverting Class-D output.
VREG	D2	P	Regulator output.

Pin Functions (continued)

PIN		TYPE	DESCRIPTION
NAME	BALL NO.		
NC3	D3	-	Float connection - do not route any signal or supply to or through this pin.
IOGND	D4	P	Digital interface ground pin.
IRQ_GPIO4	D5	I/O	Active-high interrupt pin or GPIO pin
MCLK_GPI2	D6	I	Master clock input or GPI pin.
PGND	E1	P	Power ground - connect to high current ground plane.
VSENSE_P	E2	I	Non-inverting voltage sense input.
AGND	E3	P	Analog ground - connect to low noise ground plane.
SDA_MOSI	E4	I/O	Multi-function digital pin for (SPI_SELECT= 0) : Data Pin for I ² C control bus. For (SPI_SELECT= 1): SPI data input.
WCLK2_GPIO6	E5	I/O	Audio word-clock on ASI#2 or GPIO pin.
DOUT2_GPIO7	E6	I/O	Audio data output on ASI#2 or GPIO pin.
SPK_P	F1	O	Non-inverting Class-D output.
VSENSE_M	F2	I	Inverting voltage sense input.
SCL_S SZ	F3	I	Multi-function digital input. For (SPI_SELECT= 0) : Clock Pin for I ² C Control bus. For (SPI_SELECT= 1): SPI chip selection pin.
AVDD	F4	P	1.8V analog power supply.
ADR0_SCLK	F5	I	Multi-function digital pin. For (SPI_SELECT= 0) : Device I ² C programming address LSB. For (SPI_SELECT= 1): SPI serial bit clock.
BCLK2_GPIO5	F6	I/O	Audio bit clock on ASI#2 or GPIO pin.
NC2	G1	-	Float connection - do not route any signal or supply to or through this pin.
NC1	G2	-	Float connection - do not route any signal or supply to or through this pin.
ADR1_MISO	G3	I/O	Multi-function digital input / output. For (SPI_SELECT= 0) : Device I ² C programming address MSB. For (SPI_SELECT= 1): SPI data output
SPI_SELECT	G4	I	Control interface select. 0: I ² C selected. 1: SPI selected.
/RESET	G5	I	Active-low reset.
IOVDD	G6	P	1.8V or 3.3V digital interface power supply for digital input and output levels.

8 Specifications

8.1 Absolute Maximum Ratings

Over operating free-air temperature range, $T_A = 25^\circ\text{C}$ (unless otherwise noted)⁽¹⁾

		MIN	MAX	UNIT
Battery Voltage	VBAT	-0.3	6	V
Analog Supply Voltage	AVDD	-0.3	2	V
Digital Supply Voltage	DVDD	-0.3	2	V
I/O Supply Voltage	IOVDD	-0.3	3.9	V
Digital Input Voltage		-0.3	IOVDD + 0.3	V
Output Continuous Total Power Dissipation		See Thermal Information		NA
Storage Temperature, T_{stg}		-65	150	$^\circ\text{C}$

- (1) Stresses beyond those listed under “Absolute Maximum Ratings” may cause permanent damage to the device. These are stress ratings only, and functional operation of the device at these or any other conditions beyond those indicated under [Recommended Operating Procedures](#) is not implied. Exposure to absolute–maximum–rated conditions for extended periods may affect device reliability.

8.2 ESD Ratings

		VALUE	UNIT
$V_{(ESD)}$ Electrostatic Discharge	Human-body model (HBM), per ANSI/ESDA/JEDEC JS-001 ⁽¹⁾	± 3500	V
	Charged-device model (CDM), per JEDEC specification JESD22-C101 ⁽²⁾	± 1500	

- (1) JEDEC document JEP155 states that 500-V HBM allows safe manufacturing with a standard ESD control process.

- (2) JEDEC document JEP157 states that 250-V CDM allows safe manufacturing with a standard ESD control process.

8.3 Recommended Operating Conditions

Over operating free-air temperature range (unless otherwise noted)

		MIN	NOM	MAX	UNIT
Battery Voltage	VBAT	2.9 ⁽¹⁾	3.6	5.5	V
Analog Supply Voltage	AVDD	1.65	1.8	1.95	V
Digital Supply Voltage	DVDD	1.65	1.8	1.95	V
I/O Supply Voltage 1.8V	IOVDD	1.62	1.8	1.98	V
I/O Supply Voltage 3.3V	IOVDD	3.0	3.3	3.6	V
T_A Operating Free-Air Temperature		-40		85	$^\circ\text{C}$
T_J Operating Junction Temperature		-40		150	$^\circ\text{C}$

- (1) Device is functional down to 2.7V. See [Battery Tracking AGC](#)

8.4 Thermal Information

THERMAL METRIC ⁽¹⁾		TAS2557	UNIT
		42 PINS	
$R_{\theta JA}$	Junction to Ambient Thermal Resistance	49.8	$^\circ\text{C/W}$
$R_{\theta JC(top)}$	Junction to Case (top) Thermal Resistance	0.2	
$R_{\theta JB}$	Junction to Board Thermal Resistance	7.1	
Ψ_{JT}	Junction to Top Characterization Parameter	0.8	
Ψ_{JB}	Junction to Board Characterization Parameter	7.1	
$R_{\theta JC(bot)}$	Junction to Case (bottom) Thermal Resistance	n/a	

- (1) For more information about traditional and new thermal metrics, see the *IC Package Thermal Metrics* application report, [SPRA953](#).

8.5 Electrical Characteristics

$V_{BAT} = 3.6V$, $AVDD = DVDD = IOVDD = 1.8V$, $\overline{RESET} = IOVDD$, Gain = 16.4 dB, ERC = 14ns, Boost Inductor = 2.2 μH , $R_L = 8\ \Omega + 33\ \mu H$, 1-kHz input frequency, 48- kHz sample rate for digital input, Class-H Boost Enabled, $T_A = 25^\circ C$, $I_{LIM} = 3A$ (unless otherwise noted)

PARAMETER	TEST CONDITIONS	MIN	TYP	MAX	UNIT
BOOST CONVERTER					
Boost Output Voltage	Average voltage (w/o including ripple)		8.5		V
Boost Converter Switching Frequency			1.77		MHz
Boost Converter Current Limit			3		A
Boost Converter Max In-Rush Current	High Efficiency Mode: Max inductor inrush and startup current after enable		4		A
	Normal Efficiency Mode: Max inductor inrush and startup current after enable		1.5		
CLASS-D CHANNEL					
Output Voltage for Full-Scale Digital Input			6.6		V_{RMS}
Load Resistance (Load Spec Resistance)		3.6	8		Ω
Class-D Frequency	Avg Frequency in Spread-Spectrum Mode		384		kHz
	Fixed Frequency	44.1 × 8	48 × 8		
Class-D + Boost Efficiency	$P_{OUT} = 3.5W$ (sinewave) ROM Mode 1		80		%
	$P_{OUT} = 0.5W$ (sinewave) ROM Mode 1		87		
Class-D Output Current Limit (Short Circuit Protection)	VBOOST = 8.5 V, OUT– shorted to VBAT, VBOOST, GND		6		A
Class-D Output Offset Voltage in Digital Input Mode		-2.5		2.5	mV
Programmable Channel Gain Accuracy			±0.5		dB
Mute Attenuation	Device in shutdown or device in normal operation and muted		150		dB
VBAT Power Supply Rejection Ratio (PSRR)	Ripple of 200 mVpp at 217 Hz		110		dB
AVDD Power Supply Rejection Ratio (PSRR)	Ripple of 200 mVpp at 217 Hz		99		dB
THD+N	1 kHz, $P_{OUT} = 0.1W$		0.0041		%
	1 kHz, $P_o = 0.5W$		0.0036		
	1 kHz, $P_o = 1W$		0.0035		
	1 kHz, $P_o = 3W$		0.02		
Output Integrated Noise (20Hz-20kHz) - 8 Ω	A-weighted filter, DAC modulator switching		15.9		μV
Signal-to-Noise Ratio	Referenced to 1% THD+N at output, A-weighted		110.6		dB
Max Output Power, 3-A Current Limit	THD+N=1%, 8- Ω Load		3.7		W
	THD+N=1%, 6- Ω Load		4.5		
	THD+N=1%, 4- Ω Load		5		
Startup Pop	Digital Input, A-weighted output		10		mV
Output Impedance in Shutdown	/RESET = 0 V		10		k Ω
Startup Time	Time taken from end of configuring device in ROM mode1/2 to speaker output signal in SPI mode running at 25 MHz with 48 ksp/s input		8		mS
Shutdown Time	Measured from time when device is programmed in software shutdown mode		100		μS

Electrical Characteristics (continued)

$V_{BAT} = 3.6V$, $AVDD = DVDD = IOVDD = 1.8V$, $\overline{RESET} = IOVDD$, Gain = 16.4 dB, ERC = 14ns, Boost Inductor = 2.2 μH , $R_L = 8\ \Omega + 33\ \mu H$, 1-kHz input frequency, 48- kHz sample rate for digital input, Class-H Boost Enabled, $T_A = 25^\circ C$, ILIM = 3 A (unless otherwise noted)

PARAMETER		TEST CONDITIONS	MIN	TYP	MAX	UNIT
CURRENT SENSE						
Current Sense Full Scale	Peak current which will give full scale digital output 8- Ω load		1.25		A_{PEAK}	
	Peak current which will give full scale digital output 6- Ω load		1.48			
	Peak current which will give full scale digital output 4- Ω load		1.76			
Current Sense Accuracy	$I_{OUT} = 354\ mA_{RMS}$ (1 W)		1			%
VOLTAGE SENSE						
Voltage Sense Full Scale	Peak voltage which will give full scale digital output		9.353			V_{PEAK}
Voltage Sense Accuracy	$V_{OUT} = 2.83\ V_{rms}$ (1 W)		1			%
INTERFACE						
Voltage and Current Sense Data Rate		TDM/1 ² S	48			kHz
Voltage and Current Sense ADC OSR		TDM/1 ² S	64			OSR
F_{MCLK}	MCLK frequency		0.512		49.15	MHz
POWER CONSUMPTION						
Power Consumption with Digital Input and Speaker Protection Disabled (ROM MODE 1)	From VBAT, PLL on, no signal		3			mA
	From AVDD, PLL on, no signal		3			mA
	From DVDD, PLL on, no signal		7.2			mA
Power Consumption with Digital Input and Speaker Protection Enabled	From VBAT, PLL on, no signal		4			mA
	From AVDD, PLL on, no signal		5.1			mA
	From DVDD, PLL on, no signal		22			mA
Power Consumption in Hardware Shutdown	From VBAT, /RESET = 0		0.1			μA
	From AVDD, /RESET = 0		0.2			μA
	From DVDD, /RESET = 0		2			μA
Power Consumption in Software Shutdown See Low Power Sleep	From VBAT		0.1			μA
	From AVDD		0.1			μA
	From DVDD		9.7			μA
DIGITAL INPUT / OUTPUT						
V_{IH}	High-Level Digital Input Voltage	All digital pins except SDA and SCL, IOVDD = 1.8-V operation	0.65 x IOVDD			V
V_{IL}	Low-Level Digital input Voltage		0.35 x IOVDD			V
V_{IH}	High-Level Digital Input Voltage	All digital pins except SDA and SCL, IOVDD = 3.3-V operation	2			V
V_{IL}	Low-Level Ddigital Input Voltage		0.45			V
V_{OH}	High-Level Digital Output Voltage	All digital pins except SDA and SCL, IOVDD = 1.8-V operation For $I_{OL} = 2\ mA$ and $I_{OH} = -2\ mA$	IOVDD – 0.45			V
V_{OL}	Low-Level Digital Output Vvoltage		0.45			V
V_{OH}	High-Level Digital Output Voltage	All digital pins except SDA and SCL, IOVDD = 3.3-V operation For $I_{OL} = 2\ mA$ and $I_{OH} = -2\ mA$	2.4			V
V_{OL}	Low-Level Digital Output Voltage		0.4			V
I_{IH}	High-Level Digital Input Leakage Current	Input = IOVDD	-5	0.1	5	μA
I_{IL}	Low-Level Digital Input Leakage Current	Input = Ground	-5	0.1	5	μA
MISCELLANEOUS						
T_{TRIP}	Thermal Trip Point		140			$^\circ C$

8.6 I²C Timing Requirements

For I²C interface signals over recommended operating conditions (unless otherwise noted). See [Figure 1](#)⁽¹⁾

SYMBOL	PARAMETER	CONDITIONS	Standard-Mode		Fast-Mode		UNIT
			MIN	MAX	MIN	MAX	
f _{SCL}	SCL Clock Frequency		0	100	0	400	kHz
t _{HD;STA}	Hold Time (repeated) START Condition. After this period, the first clock pulse is generated.		4		0.6		μs
t _{LOW}	LOW Period of the SCL Clock		4.7		1.3		μs
t _{HIGH}	HIGH Period of the SCL Clock		4		0.6		μs
t _{SU;STA}	Setup Time for a Repeated START Condition		4.7		0.6		μs
t _{HD;DAT}	Data Hold Time: For I ² C Bus Devices		0	3.45	0	0.9	μs
t _{SU;DAT}	Data Setup Time		250		100		ns
t _r	SDA and SCL Rise Time			1000	20 + 0.1 × Cb	300	ns
t _f	SDA and SCL Fall Time			300	20 + 0.1 × Cb	300	ns
t _{SU;STO}	Setup Time for STOP Condition		4		0.6		μs
t _{BUF}	Bus Free Time Between a STOP and START Condition		4.7		1.3		μs
C _b	Capacitive Load for Each Bus Line			400		400	pF

(1) All timing specifications are measured at characterization but not tested at final test.

8.7 SPI Timing Requirements

For SPI interface signals over recommended operating conditions (unless otherwise noted). See [Figure 2](#)⁽¹⁾

SYMBOL	PARAMETER	CONDITIONS	IOVDD = 1.8 V		IOVDD = 3.3 V		UNIT
			MIN	MAX	MIN	MAX	
t _{sck}	SCLK Period		40		30		ns
t _{sckh}	SCLK Pulse Width High		40		30		ns
t _{sckl}	SCLK Pulse Width Low		40		30		ns
t _{lead}	Enable Lead Time		40		30		ns
t _{trail}	Enable Trail Time		40		30		ns
t _{d;seqxfr}	Sequential Transfer Delay		40		30		ns
t _a	Slave DOUT Access Time			35		25	ns
t _{dis}	Slave DOUT Disable Time			35		25	ns
t _{su}	DIN Data Setup Time		8		8		ns
t _{h;DIN}	DIN Data Hold Time		8		8		ns
t _{v;DOUT}	DOUT Data Valid Time			35		25	ns
t _r	SCLK Rise Time			4		4	ns
t _f	SCLK Fall Time			4		4	ns

(1) All timing specifications are measured at characterization but not tested at final test.

8.8 I²S/LJF/RJF Timing in Master Mode

All specifications at $T_A = -40^{\circ}\text{C}$ to 85°C , IOVDD data sheet limits, V_{IL} and V_{IH} applied, V_{OL} and V_{OH} measured at datasheet limits, lumped capacitive load of 20 pF on output pins unless otherwise noted. See [Figure 3](#)⁽¹⁾

SYMBOL	PARAMETER	CONDITIONS	IOVDD = 1.8 V		IOVDD = 3.3 V		UNIT
			MIN	MAX	MIN	MAX	
$t_d(\text{WS})$	BCLK to WCLK delay	50% of BCLK to 50% of WCLK		35		25	ns
$t_d(\text{DO-WS})$	WCLK to DOUT Delay (For LJF Mode Only)	50% of WCLK to 50% of DOUT		35		25	ns
$t_d(\text{DO-BCLK})$	BCLK to DOUT Delay	50% of BCLK to 50% of DOUT		35		25	ns
$t_s(\text{DI})$	DIN Setup		8		8		ns
$t_h(\text{DI})$	DIN Hold		8		8		ns
t_r	Rise Time	10%-90% Rise Time		8		4	ns
t_f	Fall Time	90%-10% Fall Time		8		4	ns

(1) All timing specifications are measured at characterization but not tested at final test.

8.9 I²S/LJF/RJF Timing in Slave Mode

All specifications at $T_A = -40^{\circ}\text{C}$ to 85°C , IOVDD data sheet limits, V_{IL} and V_{IH} applied, V_{OL} and V_{OH} measured at datasheet limits, lumped capacitive load of 20 pF on output pins unless otherwise noted. See [Figure 4](#)⁽¹⁾

SYMBOL	PARAMETER	CONDITIONS	IOVDD = 1.8 V		IOVDD = 3.3 V		UNIT
			MIN	MAX	MIN	MAX	
$t_{H}(\text{BCLK})$	BCLK High Period		40		30		ns
$t_{L}(\text{BCLK})$	BCLK Low Period		40		30		ns
$t_s(\text{WS})$	(WS)		8		8		ns
$t_h(\text{WS})$	WCLK Hold		8		8		ns
$t_d(\text{DO-WS})$	WCLK to DOUT Delay (For LJF Mode Only)	50% of WCLK to 50% of DOUT		35		25	ns
$t_d(\text{DO-BCLK})$	BCLK to DOUT Delay	50% of BCLK to 50% of DOUT		35		25	ns
$t_s(\text{DI})$	DIN Setup		8		8		ns
$t_h(\text{DI})$	DIN Hold		8		8		ns
t_r	Rise Time	10%-90% Rise Time		8		4	ns
t_f	Fall Time	90%-10% Fall Time		8		4	ns

(1) All timing specifications are measured at characterization but not tested at final test.

8.10 DSP Timing in Master Mode

All specifications at $T_A = -40^{\circ}\text{C}$ to 85°C , IOVDD data sheet limits, V_{IL} and V_{IH} applied, V_{OL} and V_{OH} measured at datasheet limits, lumped capacitive load of 20 pF on output pins unless otherwise noted. See 图 5⁽¹⁾

SYMBOL	PARAMETER	CONDITIONS	IOVDD = 1.8 V		IOVDD = 3.3 V		UNIT
			MIN	MAX	MIN	MAX	
$t_d(\text{WS})$	BCLK to WCLK delay	50% of BCLK to 50% of WCLK	35		25		ns
$t_d(\text{DO-BCLK})$	BCLK to DOUT delay	50% of BCLK to 50% of DOUT	35		25		ns
$t_s(\text{DI})$	DIN Setup		8		8		ns
$t_h(\text{DI})$	DIN Hold		8		8		ns
t_r	Rise Time	10%-90% Rise Time	8		4		ns
t_f	Fall Time	90%-10% Fall Time	8		4		ns

(1) All timing specifications are measured at characterization but not tested at final test.

8.11 DSP Timing in Slave Mode

All specifications at 25°C , IOVDD = 1.8 V Ssee 图 6⁽¹⁾

SYMBOL	PARAMETER	CONDITIONS	IOVDD=1.8V		IOVDD=3.3V		UNIT
			MIN	MAX	MIN	MAX	
$t_H(\text{BCLK})$	BCLK High Period		40		30		ns
$t_L(\text{BCLK})$	BCLK Low Period		40		30		ns
$t_s(\text{WS})$	WCLK setup		8		8		ns
$t_h(\text{WS})$	WCLK Hold		8		8		ns
$t_d(\text{DO-BCLK})$	BCLK to DOUT Delay (For LJJ Mode Only)	50% BCLK to 50% DOUT	35		25		ns
$t_s(\text{DI})$	DIN Setup		8		8		ns
$t_h(\text{DI})$	DIN Hold		8		8		ns
t_r	Rise Time	10%-90% Rise Time	8		4		ns
t_f	Fall Time	90%-10% Fall Time	8		4		ns

(1) All timing specifications are measured at characterization but not tested at final test.



图 1. I²C Timing



图 2. SPI Interface Timing Diagram

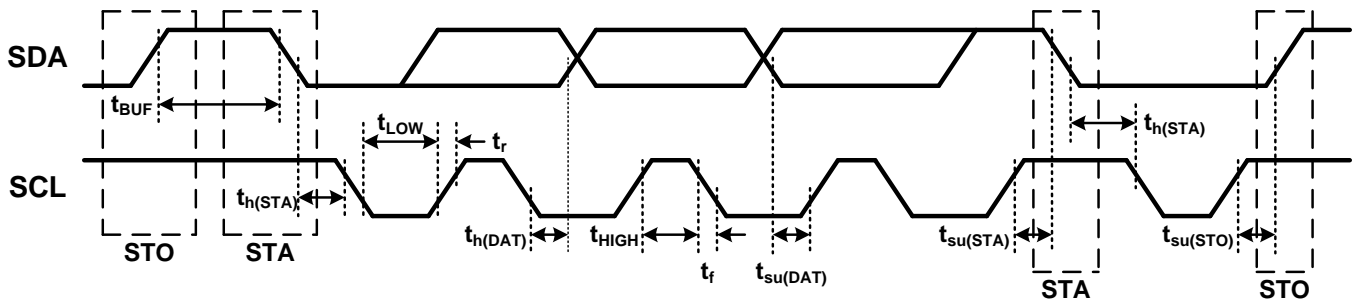

图 3. I²S/LJF/RJF Timing in Master Mode

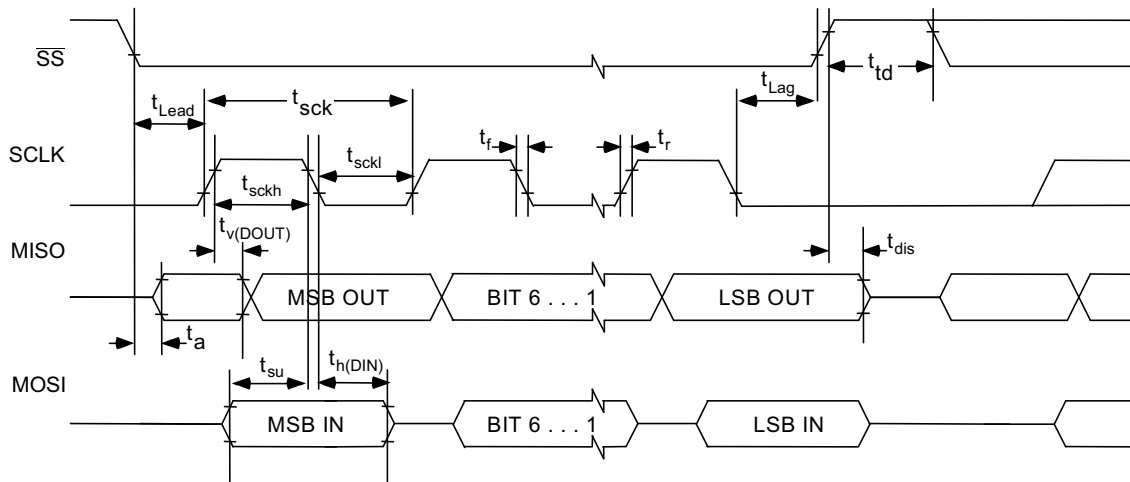

图 4. I²S/LJF/RJF Timing in Slave Mode

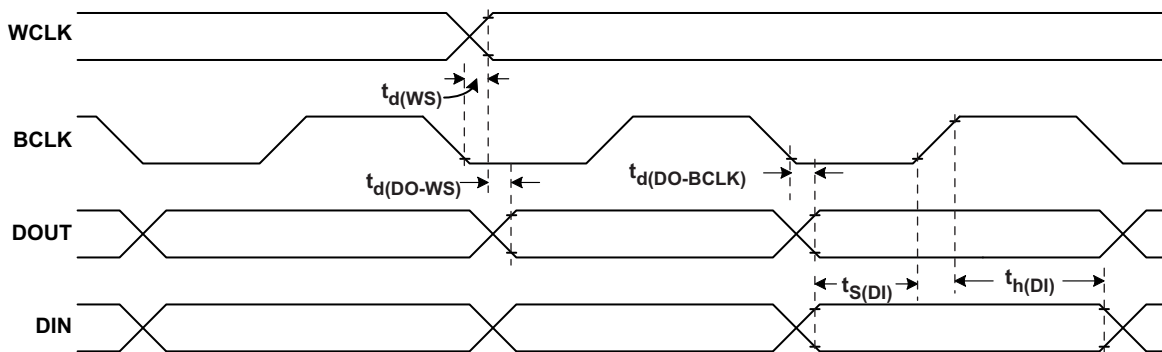

图 5. DSP Timing in Master Mode

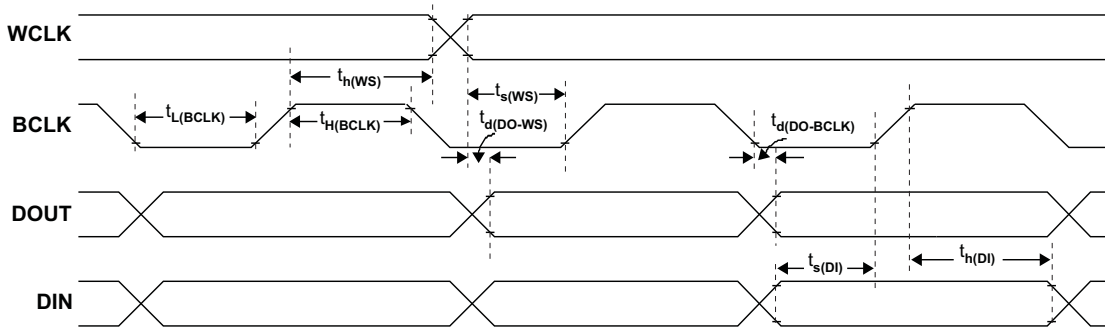

图 6. DSP Timing in Slave Mode

8.12 Typical Characteristics

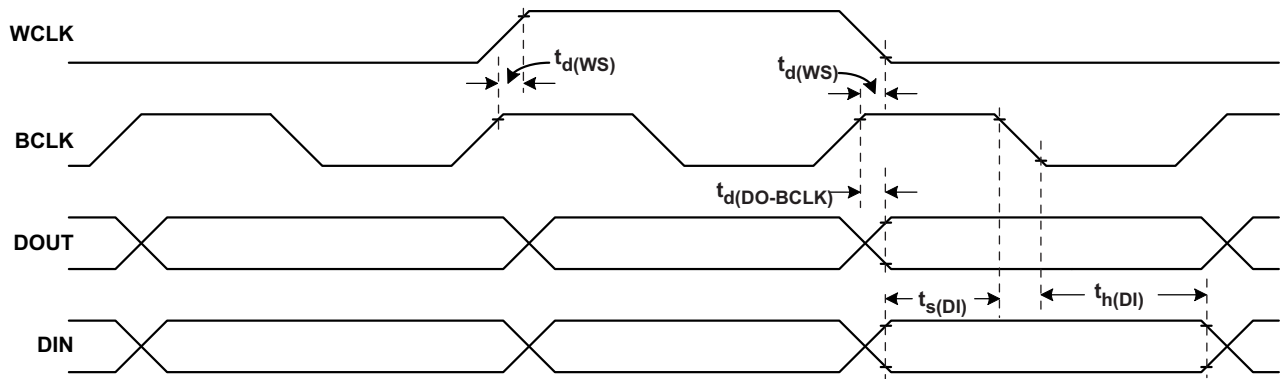
VBAT = 3.6 V, AVDD = IOVDD = 1.8 V, $\overline{\text{RESET}} = \text{IOVDD}$, $R_L = 8 \Omega + 33 \mu\text{H}$, I²S Digital Input, ROM Mode 1 (Unless Otherwise Noted).

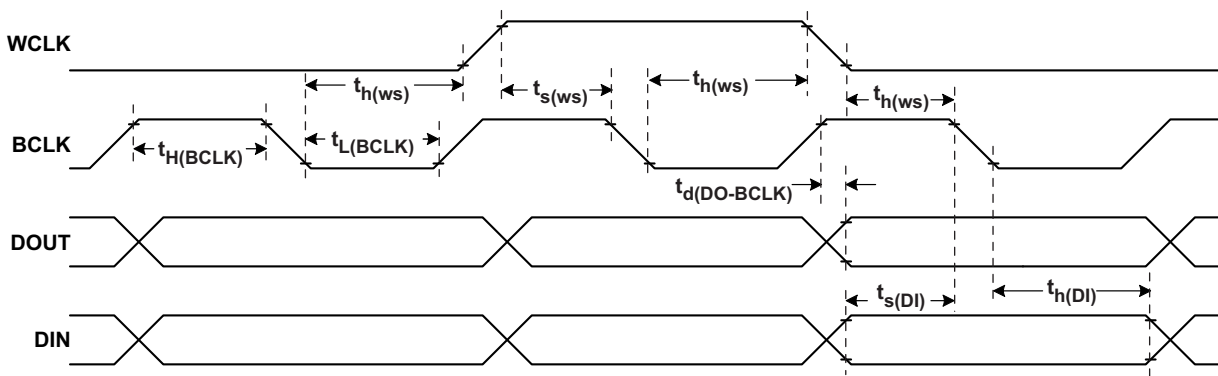

图 7. THD+N vs Output Power



图 8. THD+N vs Output Power

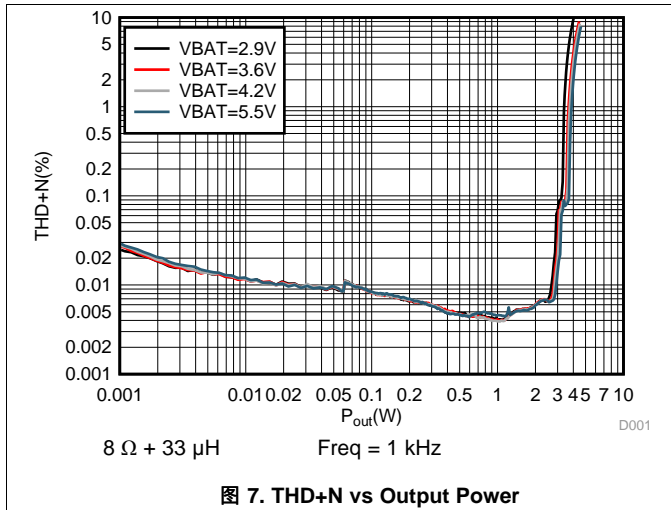

图 9. THD+N vs Frequency

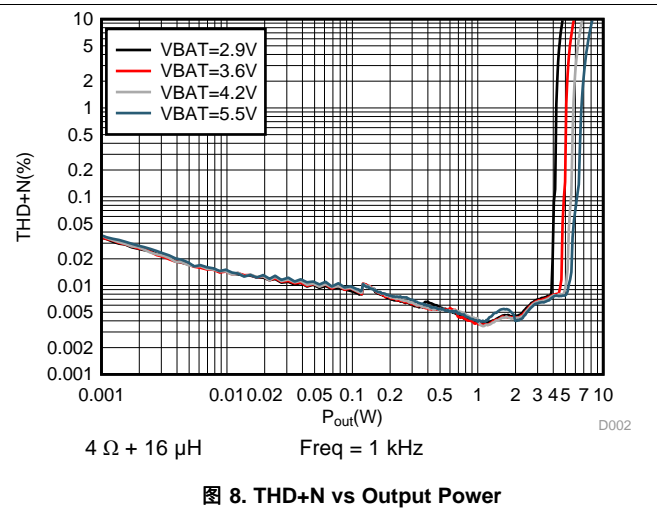

图 10. THD+N vs Frequency

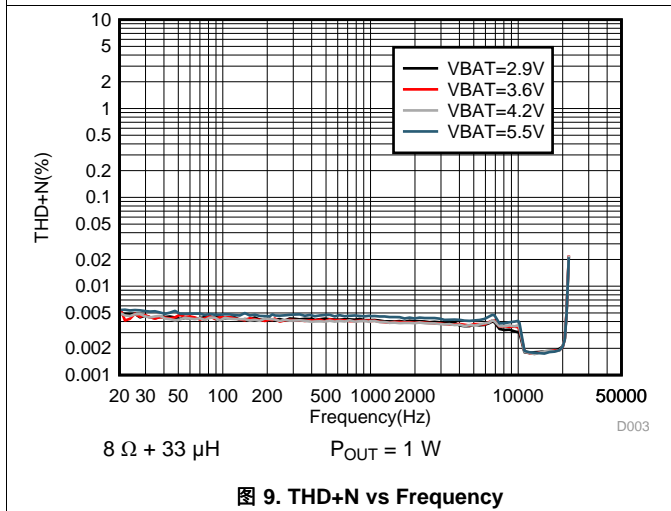

图 11. VBAT Supply Ripple Rejection vs Frequency

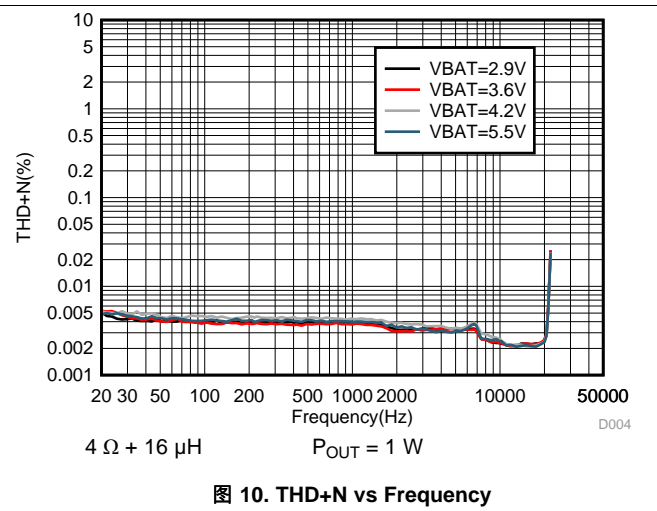

图 12. AVDD Supply Ripple Rejection vs Frequency

Typical Characteristics (接下页)

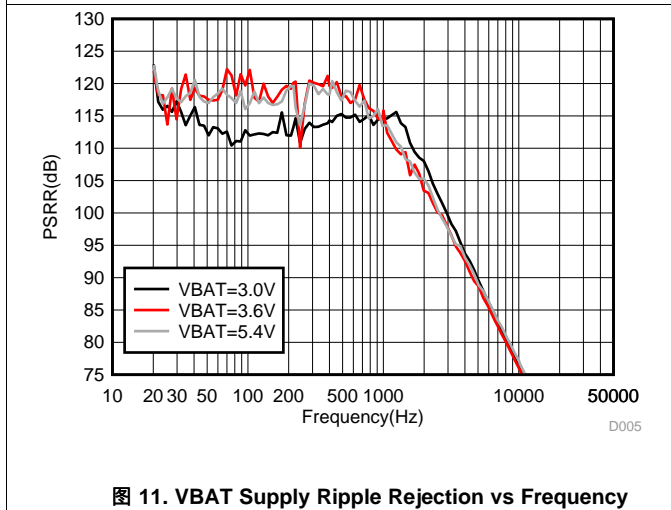
VBAT = 3.6 V, AVDD = IOVDD = 1.8 V, $\overline{\text{RESET}}$ = IOVDD, $R_L = 8 \Omega + 33 \mu\text{H}$, I²S Digital Input, ROM Mode 1 (Unless Otherwise Noted).

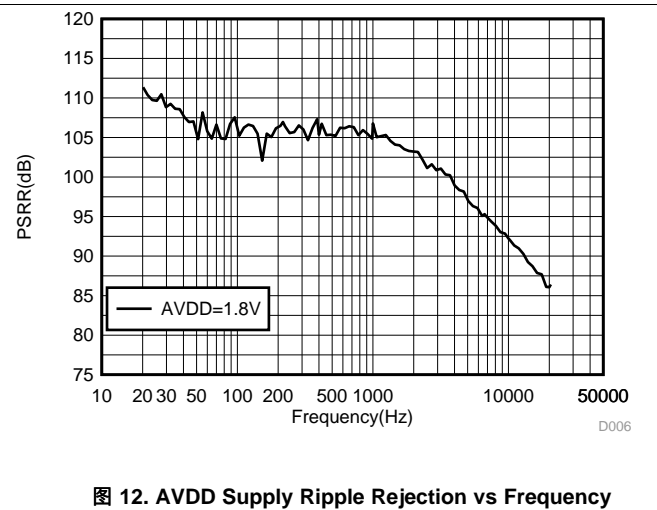

图 13. Efficiency vs Output Power



图 14. Efficiency vs Output Power

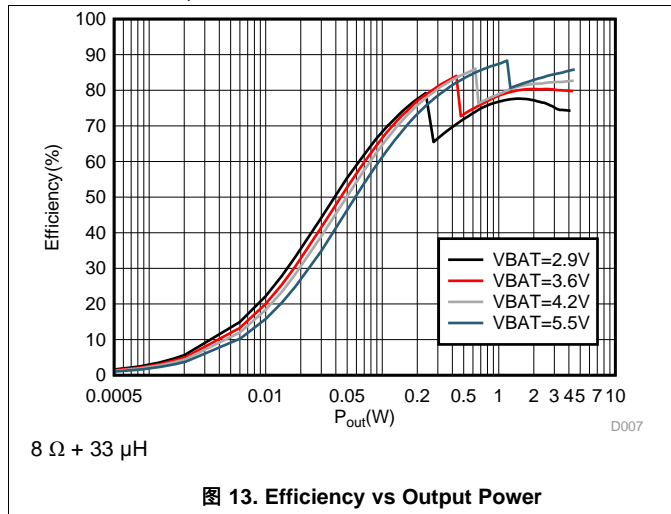

图 15. Output Power for 1% THD+N vs VBAT

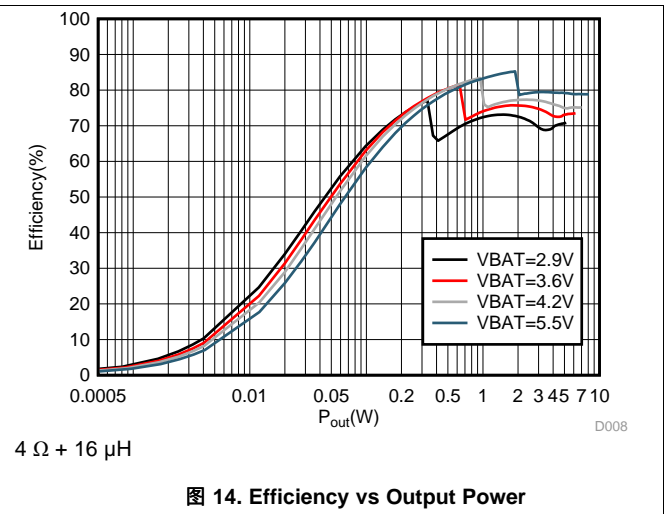

图 16. Quiescent Current vs VBAT

9 Parameter Measurement Information

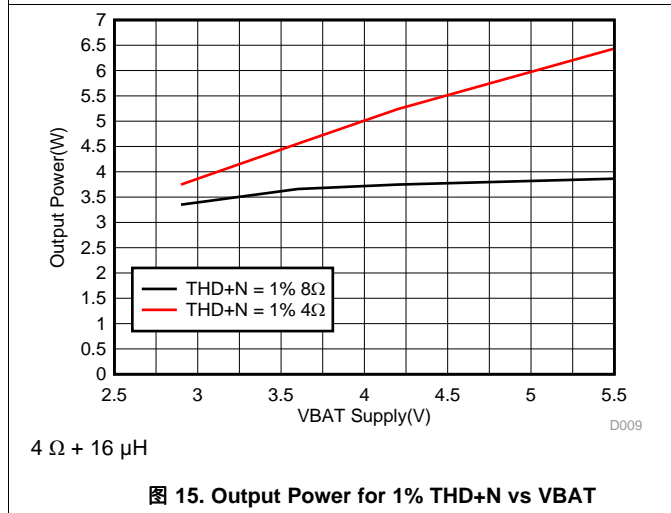

图 17. TAS2557 Test Circuit

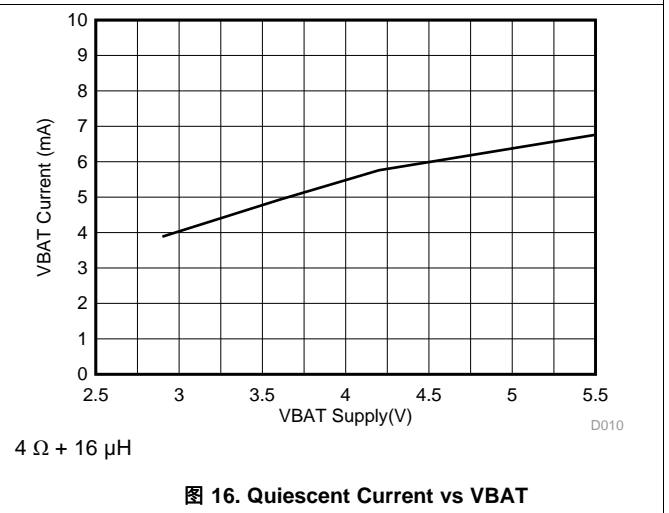
All typical characteristics for the devices are measured using the bench EVM and an Audio Precision SYS-2722 Audio Analyzer. A PSIA interface is used to allow the I²S interface to be driven directly into the SYS-2722. SPEAKER OUT terminal is connected to Audio Precision Analyzer inputs as shown below. There is a differential to single-ended (D2S) filter, with 1st order passive pole at 120 kHz added. This is to ensure high performance Class-D amplifier sees a fully differential matched loading at its outputs and while seeing no measurable degradation in performance due to loading effects of AUX filter on Class-D outputs.

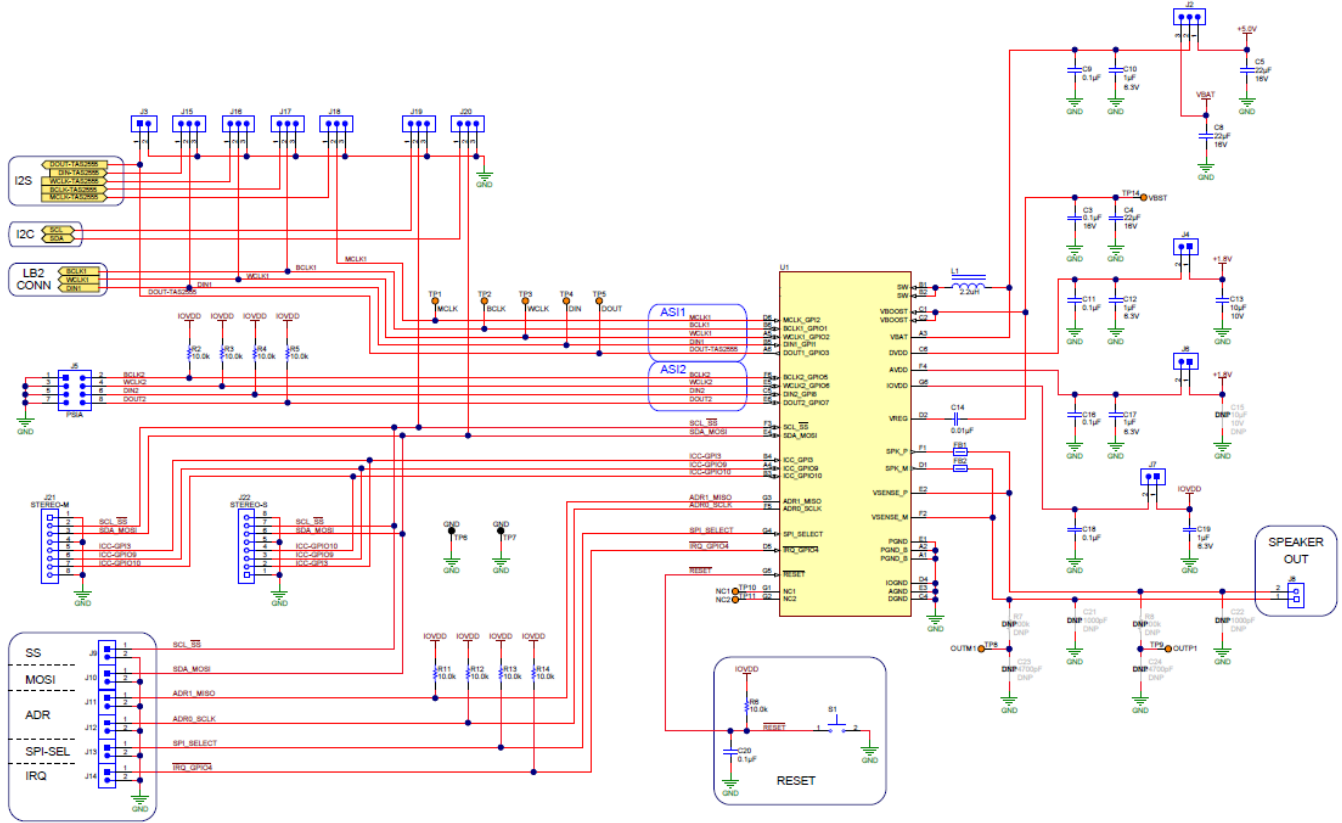

图 18. Differential To Single-Ended (D2S) Filter

10 Detailed Description

10.1 Overview

The TAS2557 device is a state-of-the-art Class-D audio amplifier which is a full system on a chip (SoC). The device features a ultra low-noise audio DAC and Class-D power amplifier which incorporates speaker voltage and current sensing feedback. An on-chip, low-latency DSP supports Texas Instruments' Smart Amp speaker protection algorithms to maximize loudness while maintaining safe speaker conditions. A smart integrated multi-level Class-H boost converter maximizes system efficiency at all times by tracking the required output voltage. The TAS2557 drives up to 3.8 W from a 4.2-V supply into an 8- Ω speaker with 1% THD, or up to up 5.7 W into a 4- Ω speaker with 1% THD.

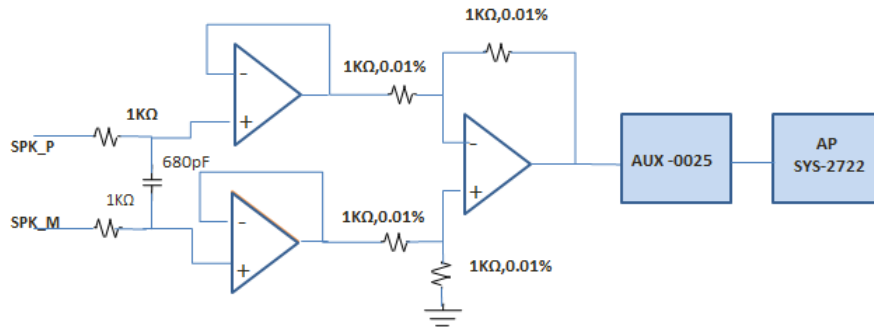
The TAS2557, with final processed digital output, can also be used to increase loudness and clarity in both Noise Canceling / Echo Cancelling speaker phone applications as well as for music or other sound applications. The TAS2557 accepts input audio data rates from 8 kHz to 96 kHz using ROM modes to fully support both speakerphone and music applications. When speaker protection system is running the maximum sampling rate is limited to 48 kHz.

The multi-level Class-H boost converter generates the Class-D amplifier supply rail. When the audio signal requires a output power below VBAT, the boost improves system efficiency by deactivating and connecting VBAT directly to the Class-D amplifier supply. When higher audio output power is required, the boost quickly activates and provides a much louder and clearer signal than can be achieved in any standard amplifier speaker system design approach. A boost inductor of 1 μ H can be used with a slight increase in boost ripple.

On-chip brownout detection system shutdown down audio at the user configurable threshold to avoid undesired system reset. In addition, an AGC can be selected to minimize clipping events when a lower power supply voltage is provided to the Class-D speaker driver. When this supply voltage drops below the proper level then under-voltage protection will be tripped. All protection statuses are available via register reads.

The Class-D output switching frequency is synchronous with the digital input audio sample rate to avoid left and right PWM frequency differences from beating in stereo applications. PWM Edge rate control and Spread Spectrum features are available if further EMI reduction is desired in the user's system.

The interrupt request pin (IRQ) indicates a device error condition. The interrupt flag condition or conditions are selectable via I²C and include: thermal overload, Class-D over-current, VBAT level low, VBOOST level low, and PLL out-of-lock conditions. The IRQ signal is active-high for an interrupt request and low during normal operation. This behavior can be changed by a register setting to tri-state the pin during normal operation to allow the IRQ pin to be tied in parallel with other active-low interrupt request pins on other devices in the system.

Stereo configuration can be achieved with two TAS2557 devices by using the ADR0_SCLK and ADR1_MISO pins to set different I²C addresses in I²C mode or the SCL_SSZ chip enable pin in SPI mode. Refer to the [General I²C Operation](#) or [General SPI Operation](#) sections for more details.

10.2 Functional Block Diagram

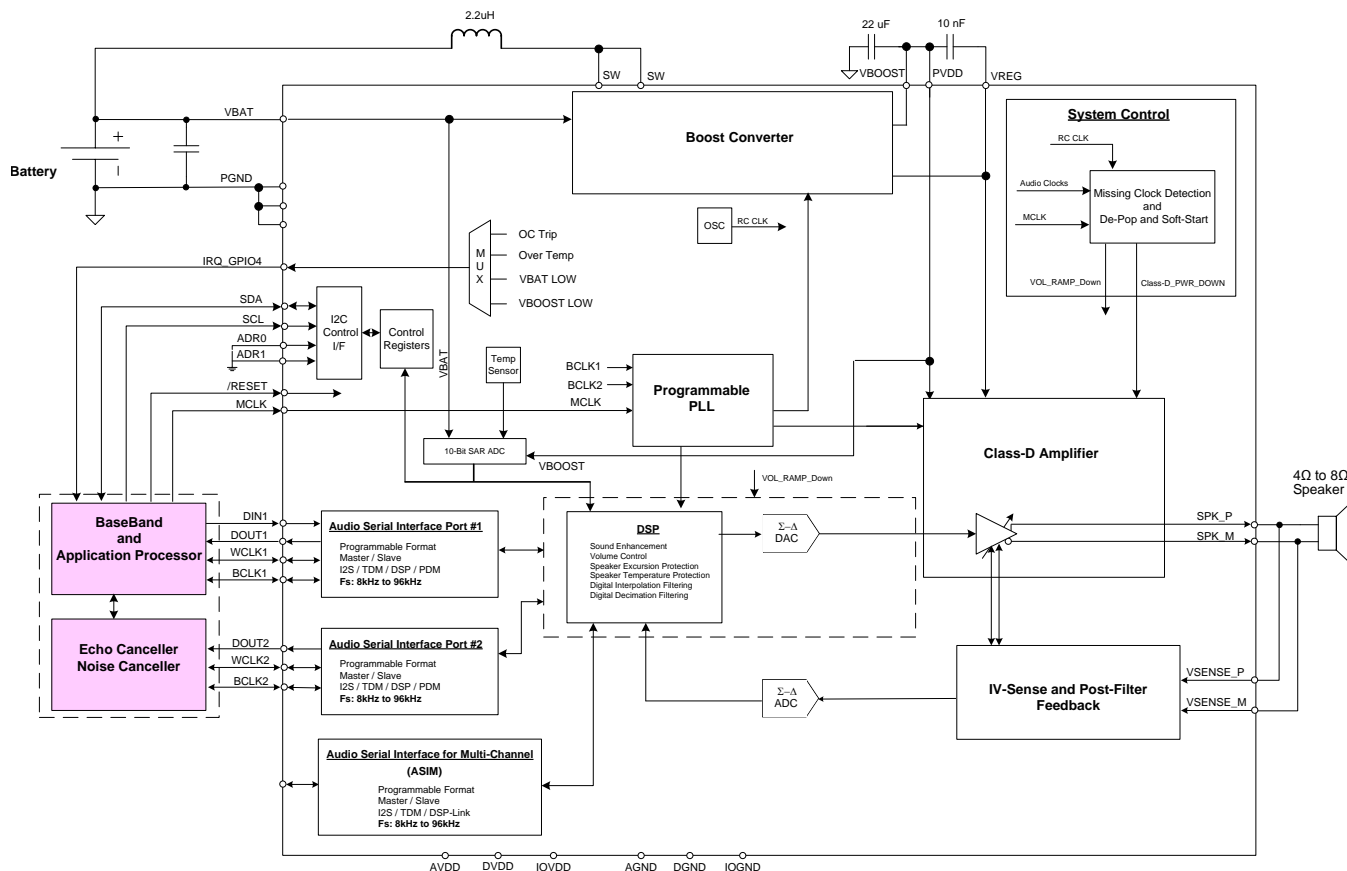

10.3 Feature Description

10.3.1 General I²C Operation

The TAS2557 operates as an I²C slave over the IOVDD voltage range. It is adjustable to one of four I²C addresses. This allows multiple TAS2557 devices in a system to connect to the same I²C bus. The I²C pins are fail-safe. If the part is not powered or is in shutdown the I²C pins will not impact the I²C bus allowing it to remain functional.

To configure the TAS2557 for I²C operation set the SPI_SELECT pin to ground. The I²C address can then be set using pins ADR0_SCLK and ADR1_MSIO according to 表 1. The pins configure the two LSB bits of the following 7-bit binary address A6-A0 of 10011xx. This permits the I²C address of TAS2557 to be 0x4C(7-bit) through 0x4F(7-bit). For example, if both ADR0_SCLK and ADR1_MSIO are connected to ground the I²C address for the TAS2557 would be 0x4C(7-bit). This is equivalent to 0x98 (8-bit) for writing and 0x99 (8-bit) for reading.

表 1. I²C Address Selection

ADR0_SCLK Pin Connection	ADR1_MSIO Pin Connection	I ² C Device Address
GND	GND	0x4C
IOVDD	GND	0x4D
GND	IOVDD	0x4E
IOVDD	IOVDD	0x4F

The I²C bus employs two signals, SDA (data) and SCL (clock), to communicate between integrated circuits in a system. The corresponding pins on the TAS2557 for the two signals are SDA_MOSI and SCL_SSZ. The bus transfers data serially, one bit at a time. The address and data (8-bit) bytes are transferred most-significant bit (MSB) first. In addition, each byte transferred on the bus is acknowledged by the receiving device with an acknowledge bit. Each transfer operation begins with the master device driving a start condition on the bus and ends with the master device driving a stop condition on the bus. The bus uses transitions on the data terminal (SDA) while the clock is at logic high to indicate start and stop conditions. A high-to-low transition on SDA indicates a start, and a low-to-high transition indicates a stop. Normal data-bit transitions must occur within the low time of the clock period. 图 19 shows a typical sequence.

The master generates the 7-bit slave address and the read/write (R/W) bit to open communication with another device and then waits for an acknowledge condition. The device holds SDA low during the acknowledge clock period to indicate acknowledgment. When this occurs, the master transmits the next byte of the sequence. Each device is addressed by a unique 7-bit slave address plus R/W bit (1 byte). All compatible devices share the same signals via a bi-directional bus using a wired-AND connection.

Use external pull-up resistors for the SDA and SCL signals to set the logic-high level for the bus. Use pull-up resistors between 660 Ω and 4.7 kΩ. Do not allow the SDA and SCL voltages to exceed the device supply voltage, IOVDD.



图 19. Typical I²C Sequence

There is no limit on the number of bytes that can be transmitted between start and stop conditions. When the last word transfers, the master generates a stop condition to release the bus. 图 19 shows a generic data transfer sequence.

10.3.2 Single-Byte and Multiple-Byte Transfers

The serial control interface supports both single-byte and multiple-byte read/write operations for all registers. During multiple-byte read operations, the TAS2557 responds with data, a byte at a time, starting at the register assigned, as long as the master device continues to respond with acknowledges.

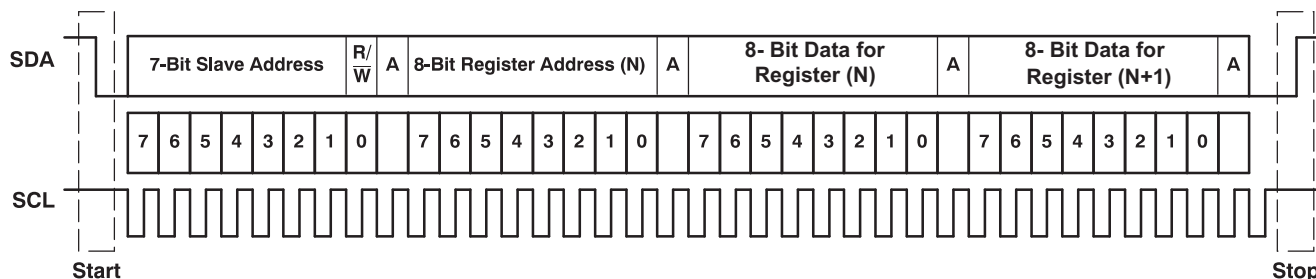
The TAS2557 supports sequential I²C addressing. For write transactions, if a register is issued followed by data for that register and all the remaining registers that follow, a sequential I²C write transaction has taken place. For I²C sequential write transactions, the register issued then serves as the starting point, and the amount of data subsequently transmitted, before a stop or start is transmitted, determines to how many registers are written.

10.3.3 Single-Byte Write

As shown in 图 20, a single-byte data-write transfer begins with the master device transmitting a start condition followed by the I²C device address and the read/write bit. The read/write bit determines the direction of the data transfer. For a write-data transfer, the read/write bit must be set to 0. After receiving the correct I²C device address and the read/write bit, the TAS2557 responds with an acknowledge bit. Next, the master transmits the register byte corresponding to the device internal memory address being accessed. After receiving the register byte, the device again responds with an acknowledge bit. Finally, the master device transmits a stop condition to complete the single-byte data-write transfer.



图 20. Single-Byte Write Transfer

10.3.4 Multiple-Byte Write and Incremental Multiple-Byte Write

A multiple-byte data write transfer is identical to a single-byte data write transfer except that multiple data bytes are transmitted by the master device to the TAS2557 as shown in 图 21. After receiving each data byte, the device responds with an acknowledge bit.

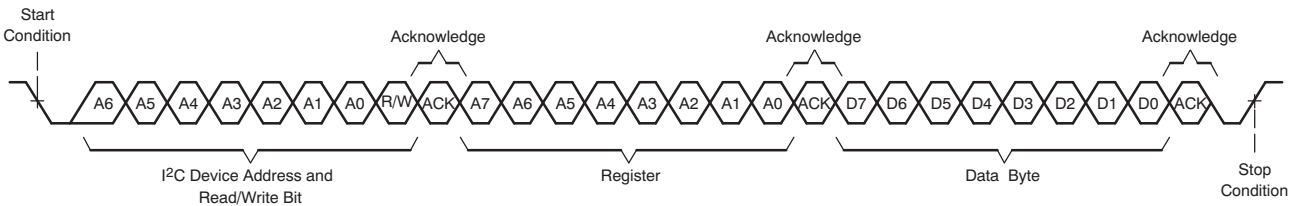

图 21. Multiple-Byte Write Transfer

10.3.5 Single-Byte Read

As shown in 图 22, a single-byte data-read transfer begins with the master device transmitting a start condition followed by the I²C device address and the read/write bit. For the data-read transfer, both a write followed by a read are actually done. Initially, a write is done to transfer the address byte of the internal memory address to be read. As a result, the read/write bit is set to a 0.

After receiving the TAS2557 address and the read/write bit, the device responds with an acknowledge bit. The master then sends the internal memory address byte, after which the device issues an acknowledge bit. The master device transmits another start condition followed by the TAS2557 address and the read/write bit again. This time, the read/write bit is set to 1, indicating a read transfer. Next, the TAS2557 transmits the data byte from the memory address being read. After receiving the data byte, the master device transmits a not-acknowledge followed by a stop condition to complete the single-byte data read transfer.

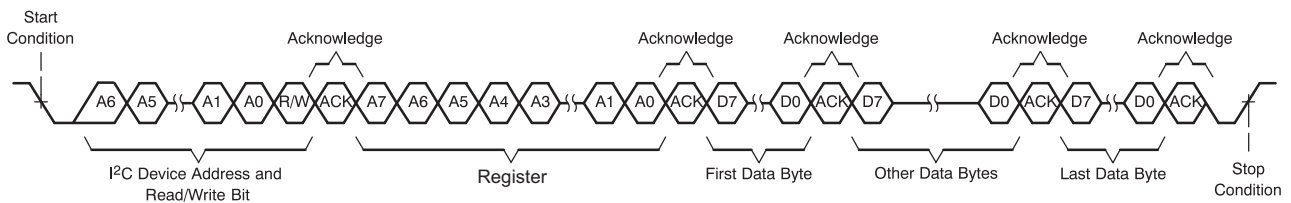

图 22. Single-Byte Read Transfer

10.3.6 Multiple-Byte Read

A multiple-byte data-read transfer is identical to a single-byte data-read transfer except that multiple data bytes are transmitted by the TAS2557 to the master device as shown in 图 23. With the exception of the last data byte, the master device responds with an acknowledge bit after receiving each data byte.

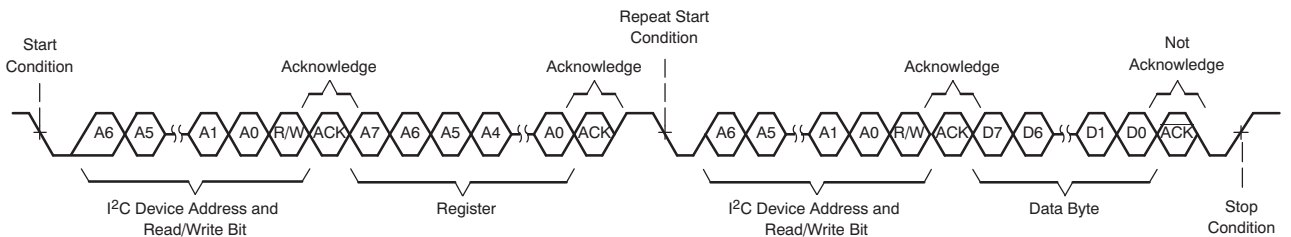

图 23. Multiple-Byte Read Transfer

10.3.7 General SPI Operation

The TAS2557 operates as an SPI slave over the IOVDD voltage range.

10.3.8 Class-D Edge Rate Control

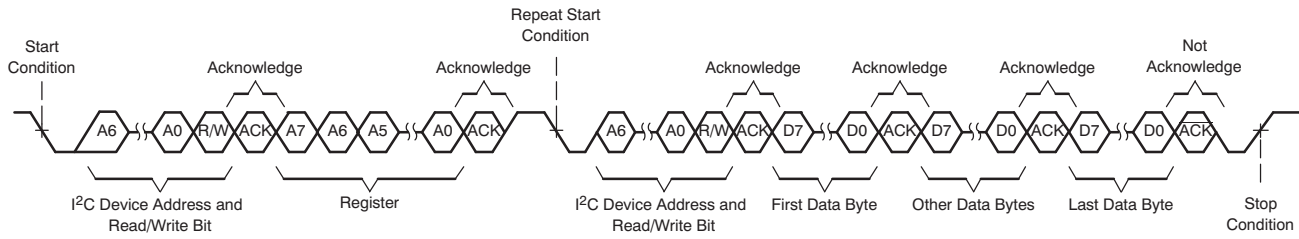
The edge rate of the Class-D output is controllable via I²C as shown in 表 2. This allows adjusting the switching edge rate of the Class-D amplifier, trading off efficiency for lower EMI. The default edge rate of 14ns passes EMI testing and is recommend but may be changed if required.

表 2. Class-D Edge Rate Control

SPK_GAIN_EDGE[2:0] (EDGE_RATE)	t _R AND t _F (TYPICAL)
000	Reserved
001	Reserved
010	29 ns
011	25 ns
100	14 ns (default)
101	13 ns
110	12 ns
111	11 ns

10.3.9 IV Sense

The TAS2557 provides speaker voltage and current sense for real-time monitoring of loudspeaker behavior. The VSENSE_P and VSENSE_N pins should be connected after any ferrite bead filter (or directly to the SPK_P and SPK_N connections if no EMI filter is used). The V-Sense terminals are used to eliminate IR drop error due to packaging, PCB interconnect, and ferrite bead filter resistance. The V-sense terminals are also used to close the Class-D feedback loop post filter. This Post-Filter Feedback (PFFB) minimizes the THD introduced from the filter-beads used in the system. Any interconnect resistance or non-linearities after the V-Sense terminals connection point will not be corrected for. Therefore, it is advised to connect the sense connections as close to the load as possible.



图 24. V-Sense Connections

The I-Sense can be configured for three ranges and shown in 表 3. This should be set appropriately based on the DC resistance of the speaker. I-Sense and V-Sense can additionally be powered down as shown in 表 4 and 表 5. When powered down, the device will return null samples for the powered down sense channels.

表 3. I-Sense Current Range

SNS_CTRL[2:1] (ISNS_SCALE)	Full Scale Current	Speaker Load Impedance
00	1.25 A (default)	8 Ω
01	1.5 A	6 Ω
10	1.75 A	4 Ω
11	Reserved	Reserved

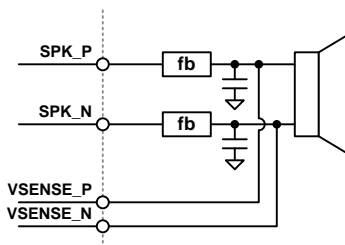
表 4. I-Sense Mute

MUTE[1] (MUTE_ISNS)	Setting
0	I-Sense is active (default)
1	I-Sense channel is muted

表 5. V-Sense Mute

MUTE[0] (MUTE_VSNS)	Setting
0	V-Sense is active (default)
1	V-Sense channel is muted

表 6. I-Sense Power Down

POWER_2[1] (PWR_ISNS)	Setting
0	I-Sense is active (default)
1	I-Sense is powered down

表 7. V-Sense Power Down

POWER_2[0] (PWR_VSNS)	Setting
0	V-Sense is active (default)
1	V-Sense is powered down

10.3.10 Battery Tracking AGC

The TAS2557 monitors the battery voltage and audio signal to automatically decrease gain when the battery voltage is low and audio output power is high. This provides louder audio while preventing early shutdown at end-of-charge battery voltage levels. The battery tracking AGC starts to attenuate the signal once the voltage at the Class-D output exceeds V_{LIM} for a given battery voltage (VBAT). If the Class-D output voltage is below the V_{LIM} value, no attenuation occurs. If the Class-D output exceeds the V_{LIM} value the AGC starts to attack the signal and reduce the gain until the output is reduced to V_{LIM} . Once the signal returns below V_{LIM} plus some hysteresis the gain reduction decays. The V_{LIM} is constant above the user configurable inflection point. Below the inflection point the V_{LIM} is reduced by a user configurable slope in relation to the battery voltage. The attack time, decay time, inflection point and $V_{LIM}/VBAT$ slope below the inflection point are user configurable. The parameters for the battery tracking AGC are part of the DSP core and can be set using the [PurePath™ Console 3 Software TAS2557 Application](#) software for the TAS2557 part under the Device Control Tab. Below a VBAT level of 2.9 V, the boost will turn on to ensure correct operation but results in increased current consumption. The device is functional until the set brownout level is reached and the device shuts down. The minimum brownout voltage is 2.7 V.

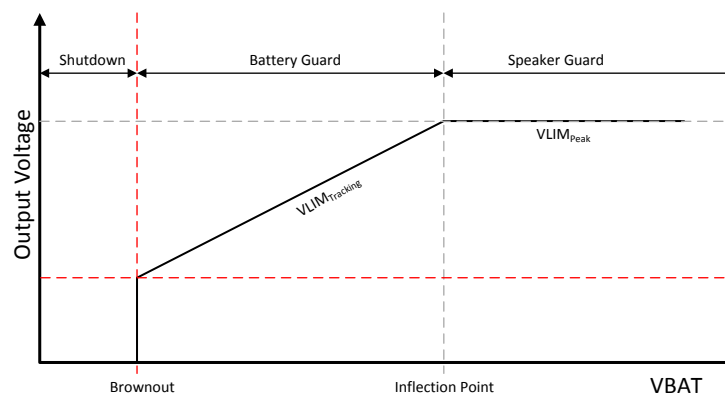
图 25. V_{LIM} versus Supply Voltage (VBAT)

10.3.11 Boost Control

10.3.11.1 Boost Mode

The TAS2557 internal processing algorithm automatically enables the boost when needed. A look-ahead algorithm monitors the battery voltage and the digital audio stream. When the speaker output approaches the battery voltage the boost is enabled in-time to supply the required speaker output voltage. When the boost is no longer required it is disabled and bypassed to maximize efficiency. The boost can be configured in one of two modes. The first is low in-rush (Class-G) supporting only boost on-off and has the lowest in-rush current. The second is high-efficiency (Class-H) where the boost voltage level is adjusted to a value just above what is needed. This mode is more efficient but has a higher in-rush current to quickly transition the levels. This can be configured using [表 8](#).



图 26. Boost Mode Signal Tracking Example

表 8. Boost Mode

SPK_CTRL[4] (BST_MODE)	Boost Mode
0	Class-H - High efficiency
1	Class-G - Low in-rush (default)

10.3.11.2 Configurable Boost Current Limit (ILIM)

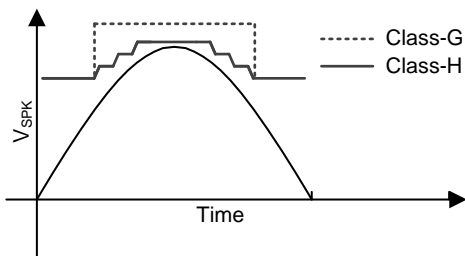
The TAS2557 device has a configurable boost current limit (ILIM). The default current limit is 3 A but this limit may be set lower based on selection of passive components connected to the boost. The TAS2557 device supports 4 different boost limits.

表 9. Current Limit Settings

BOOST_CTRL_2[1:0] (BST_ILM)	BOOST CURRENT LIMIT (A)
00	1.5
01	2.0
10	2.5
11	3.0 (default)

10.3.12 Thermal Fold-back

The TAS2557 monitors the die temperature and prevents it from going over a set limit. When enabled, an internal controller will automatically adjust the signal path gain to prevent the die temperature from exceeding this limit. This allows instantaneous peak power to be delivered to the speaker while limiting the continuous power to prevent thermal shutdown. The configuration parameters for the thermal fold-back are part of the DSP core and can be set using the [PurePath™ Console 3 Software TAS2557 Application](#) software for the TAS2557 part under the Device Control Tab.

10.3.13 Fault Protection

The TAS2557 has several protection blocks to prevent damage. Use of these blocks including how to resume from a fault are presented in this section.

10.3.13.1 Speaker Over-Current

The TAS2557 has an integrated over-current protection that is enabled once the Class-D is powered up. Large currents in the range of 3-5 A on the Class-D output will trigger an over-current fault. Once the fault is detected, the TAS2557 disables the audio channel and powers down the Class-D amplifier. When an over-current event occurs, a status flag INT_OC is set. This register is sticky, and the bit remains high until the bit is read or the device is reset. The over-current event can also be used to generate an interrupt if required. Refer to [IRQs and Flags](#) section for more details. To re-enable the audio channel after a fault the Class-D, the device must be hardware or software reset and configuration must be re-loaded.

10.3.13.2 Analog Under-Voltage

The TAS2557 has integrated undervoltage protection on the analog power supply lines AVDD and VBAT. The undervoltage limit fault is triggered when AVDD is less than 1.5 V or when VBAT is less than 2.4 V. Once the fault is detected the TAS2557 will disable the audio channel and power down the Class-D amplifier. When an under-voltage event occurs, a status flag INT_UV is set. This register is sticky and the bit will remain high until the bit is read or the device is reset. The undervoltage event can also be used to generate an interrupt if required. Refer to [IRQs and Flags](#) section for more details. To re-enable the audio channel after a fault, the Class-D must be re-enabled by setting PWR_SPK high. All other configurations are preserved and the audio channel will power up with the last configured settings.

10.3.13.3 Die Over-Temperature

The TAS2557 has an integrated over-temperature protection that is enabled once the Class-D is powered up. If the device internal junction temperature exceeds the safe operating region it will trigger the over-temperature fault. Once the fault is detected the TAS2557 disables the audio channel and powers down the Class-D amplifier. The device waits until the user reads the over-temperature flag INT_OT to re-enable the Class-D amplifier if the junction temperature returns into a safe operating region. When an over-temperature event occurs, a status flag INT_OT is set. This register is sticky and the bit will remain high for as long as it is not read, or the device is not reset. The over-temperature event can also be used to generate an interrupt if required. Refer to [IRQs and Flags](#) section for more details. The over-temperature automatic re-enable can be disabled by setting OT_RT signal. If the automatic re-enable is disabled, the Class-D must be re-enabled by setting PWR_SPK high after the over-temperature fault. All other configurations are preserved and the audio channel will power up with the last configured settings.

10.3.13.4 Clocking Faults

The TAS2557 has two clock error detection blocks. The first is on the Audio Serial Interfaces (ASI). If a clock error is detected on the ASI interfaces, audio artifacts can occur at the Class-D output. When enabled, the ASI clock error detection can mute the device and shutdown the Class-D and DSP core. The clock error detection block is enabled by setting register signal CE1_EN. The ASI1 or ASI2 clocks can be routed to the block for detection using register CE1_IC. Additionally, the clock error can be routed to an interrupt pin, and the sticky bit INT_CLK1 indicates whether the clock error occurred. The second clock error detection block can monitor the DAC, ADC, and PLL clocks. When a clock error is detected, the output is soft-muted and the Class-D powered down. This clock error detection is enabled using bit signal CE2_EN and can be routed to the interrupt pin. It is indicated in the sticky bit INT_CLK2.

When a clocking error occurs, the following sequence should be performed to restart the device.

- Clear the clock error interrupts by reading the sticky flags at registers INT_STICKY_2 and INT_STICKY_2
- Clear the power error signal PWR_ERR in register POWER_1

10.3.14 Brownout

The TAS2557 has an integrated brownout system to shutdown the device when the battery voltage drops to an insufficient level. This user configurable level can be set under Device Control in the [PurePath™ Console 3 Software TAS2557 Application](#). When brownout event occurs a status flag INT_BO is set. This register is sticky, and the bit remains high until the bit is read or the device is reset. The brownout event can also be used to generate an interrupt if required. Refer to [IRQs and Flags](#) section for more details. Once the battery voltage drops below the defined threshold, the following actions occur.

- The audio playback is muted in a soft-stepping manner
- DSP, clock dividers, and analog blocks are powered down

- Sticky bit INT_BO is set

Once the host is aware of the brownout, it should set PWR_ERR register signal low to put the TAS2557 device in software shutdown and enters low power mode. Once the battery supply is stable above the defined brownout threshold the host can re-enable the device using the power control registers POWER_1 and POWER_2.

10.3.15 Spread Spectrum vs Synchronized

The Class-D switching frequency can be selected to work in two different modes of operations. This configuration needs to be done before powering up the audio channel. The first is a synchronized mode where the Class-D frequency is synchronized to the audio input sample rate. This is the default mode of operation and should be used in stereo applications to avoid inter-modulation beating of the Class-D frequency from multiple chips. The Class-D switching frequency in this mode can be configured as 384 kHz or 352.8 kHz. The 384 kHz frequency is the default mode of operation and can be used for input signals running on clock rates of 48 kHz or its sub-multiples. For input signals running on clock rate of 44.1 kHz and its sub-multiples, the switching frequency can be selected as 352.8 kHz using [表 10](#).

The second mode uses the internal oscillator to generate the ramp clock. This is enabled using [表 11](#). This mode is generally used with [表 12](#) enabled for spread-spectrum. Spread-spectrum is used to reduce wideband spectral content improving EMI emissions radiated by the speaker. In this mode, the Class-D switching frequency can varies $\pm 5\%$ or $\pm 10\%$ as set by [表 13](#) about the set frequency [表 10](#).

The configuration for this block should be set using the [PurePath™ Console 3 Software TAS2557 Application](#) software for the TAS2557 part under the Device Control Tab.

表 10. Ramp Clock Frequency

RAMP_CTRL[5:4] (RAMP_FREQ)	Setting
00	384 kHz (default)
01	352.8 kHz
10	Reserved
11	Reserved

表 11. Ramp Clock Source

RAMP_DSP[7] (RAMP_SRC)	Setting
0	Sync Mode - ramp generated from digital audio clock (default)
1	Fixed Frequency Mode(FFM) - ramp generated from internal oscillator

表 12. Ramp Clock SSM

SSM_CTRL[0] (SSM_EN)	Setting
0	SSM mode is disabled
1	SSM mode is enabled ⁽¹⁾

(1) Ramp clock source must be from internal oscillator

表 13. Ramp SSM Mode

RAMP_CTRL[1:0] (RAMP_FREQMOD)	Setting
00	Reserved
01	SSM mode enabled with ramp frequency modulated for $\pm 5\%$ (default)
10	SSM mode enabled with ramp frequency modulated for $\pm 10\%$
11	Reserved

10.3.16 IRQs and Flags

Internal device flags such as over-current, under-voltage, etc. can be routed as interrupts. The device has 4 interrupts (INT1 - INT4) that can be routed to any of the 10 GPIO pins. If more than one flag is assigned to the same interrupt, the interrupt output is the logical OR-ing of all flags. If multiple flag's are assigned to the same interrupt, the host should then query the flags sticky register to determine which event triggered the interrupt. The 10 GPIO pins can be configured for any interrupt and can be configured using GPIOx_PIN registers.

表 14. Interrupt Registers

Flag Description	Sticky Register Bit	Register to Route Flag to Interrupt
Over-Current	INT_DET_1[7] (INT_OC)	INT_GEN_1[6:4] (INT_GEN_OC)
Under-Voltage	INT_DET_1[6] (INT_UV)	INT_GEN_1[2:0] (INT_GEN_OV)
Over-Temperature	INT_DET_1[4] (INT_OT)	INT_GEN_2[2:0] (INT_GEN_OT)
Brownout	INT_DET_1[3] (INT_BO)	INT_GEN_3[6:4] (INT_GEN_BO)
Clock Lost	INT_DET_1[2] (INT_CL)	INT_GEN_4[2:0] (INT_GEN_CL)
SAR Complete	INT_DET_1[1] (INT_SC)	INT_GEN_4[6:4] (INT_GEN_SC)
Clock Error 1	INT_DET_2[3] (INT_CE1)	INT_GEN_2[6:4] (INT_GEN_CE1)
Clock Error 2	INT_DET_2[2] (INT_CE2)	INT_GEN_3[3:0] (INT_GEN_CE2)

For example, to route the brownout and under-voltage flags to GPIO5 (Pin IRQ_GPIO5) the following register settings would be used. The brownout flag would be routed to INT1 by setting INT_GEN_BO=001, and under-voltage flag would also be routed to INT1 by setting INT_GEN_OV=001. The pin IRQ_GPIO4 would be set to use INT1 by setting GP4_OUT=0x07

10.3.17 Software Reset

The TAS2557 internal logic must be initialized to a known condition for proper device function by doing a software reset. Performing software reset after a hardware reset is mandatory for reliable device boot up. To perform software reset, write high register signal RESET. After reset, all registers are initialized with default values as listed in the [Register Map](#), and no register read/write should be performed within 100us.

10.3.18 PurePath™ Console 3 Software TAS2557 Application

The TAS2557 contains an integrated DSP engine for speaker protection. PurePath™ Console 3 (PPC3) is the software tool used to setup most device configurations and tuning features. Once the software is downloaded and installed from the TI website, the TAS2557 application can be download from within the software. This datasheet refers to options that can be configured using the PPC3 software tool.

PurePath Console 3 is an intuitive graphical user interface (GUI) for characterizing and tuning speakers. Step-by-step wizards guide developers through speaker characterization and system calibration. After characterization, the PPC3 provides visual representations of speaker capabilities and frequency response. Easy to use, real-time tuning information supported via mouse-over and complete process walk-throughs. PPC3 has full access to device registers and is the simplest way to modify device settings, EVM and learning board configuration. From speaker assessment to production, PPC3 is your simple, single development tool.

10.4 Device Functional Modes

10.4.1 Audio Digital I/O Interface

Audio data is transferred between the host processor and the TAS2557 via the digital audio serial interface (ASI), or audio bus. The ASI buses (ASI1 and ASI2) can be configured for left or right-justified, I2S, DSP, or TDM modes of operation. Standard telephony PCM interfaces are supported within the TDM mode.. These modes are all MSB-first, with data width programmable to 16, 20, 24, or 32 bits. In addition, the WCLK and BCLK can be independently configured in either master or slave mode for flexible connectivity to a wide variety of processors. The word clock is used to define the beginning of a frame, and may be programmed as either a pulse or a square-wave signal. The frequency of this clock corresponds to the maximum of the selected ADC and DAC sampling frequencies.

表 15. ASI PCM Mode

ASI1_FORMAT[4:2] (ASI1_MODE)	ASI2_FORMAT[4:2] (ASI2_MODE)	ASI Function Mode
000	000	I ² S Mode (default)
001	001	DSP Mode
010	010	Right-Justified Mode (RJF)
011	011	Left-Justified Mode (LJF)
100	100	Mono PCM Mode

表 16. ASI PCM Input Word Length

ASI1_FORMAT[1:0] (ASI1_LENGTH)	ASI2_FORMAT[1:0] (ASI2_LENGTH)	Word Length
00	00	16 bits
01	01	20 bits
10	10	24 bits (default)
11	11	32 bits

The bit clock (BCLK) is used to clock in and clock out the digital audio data across the serial bus. This signal can be programmed to generate variable clock pulses by controlling the BCLK multiply-divide factor in Registers 0x08 through 0x10. The number of BCLK pulses in a frame may need adjustment to accommodate various word-lengths as well as to support the case when multiple TAS2557 devices may share the same audio bus.

The TAS2557 also includes a feature to offset the position of start of data transfer with respect to the wordclock (WCLK). This offset is specified in number of BCLKs. This can be used in cases where there is a non-zero bit-clock delay from WCLK edge or to support TDM modes of operation. The TAS2557 can place the DOUT line into a Hi-Z (tri-state) condition during all BCLKs when valid data is not being sent. TDM mode is useable with I²S, LJF, RJF, and DSP interface modes and is required for stereo applications when more than one TAS2557 part is used. The TAS2557 also has a bus keeper circuit that can be enabled in tri-state mode. The bus-keeper is a weak internal latch that will hold the data line state without the need for external pull-up or pull-down resistors while signal lines are in the Hi-Z or non-driven state.

表 17. ASI OFFSET1

ASI1_OFFSET_1 (ASI_OFFSET1)	ASI2_OFFSET_1 (ASI2_OFFSET1)	BCLKs from WCLK edge for data channel
0x00	0x00	0 (default)
0x01	0x01	1
0x02	0x02	2
...
0xFF	0xFF	255

表 18. ASI Tri-state

ASI1_FORMAT[0] (ASI1_TRISTATE)	ASI2_FORMAT[0] (ASI2_TRISTATE)	Tri-state DOUT for extra BCLK cycles after frame is complete
0	0	disabled (default)
1	1	enabled

表 19. ASI Bus-keeper

ASI1_BUSKEEP[7] (ASI1_BKP)	ASI2_BUSKEEP[7] (ASI2_BKP)	Tri-state DOUT for extra BCLK cycles after frame is complete
0	0	disabled (default)
1	1	enabled

TAS2557

ZHCSFP7A – NOVEMBER 2016 – REVISED FEBRUARY 2017

www.ti.com.cn

Additional configuration options for the ASI1 and ASI2 interface can be found in the [Register Map](#). It is recommended to use the [PurePath™ Console 3 Software TAS2557 Application](#) software for TAS2557 to configure the ASI interfaces.

10.4.1.1 I²S Mode

In I²S mode, the MSB of the left channel is valid on the second rising edge of the bit clock after the falling edge of the word clock. Similarly the MSB of the right channel is valid on the second rising edge of the bit clock after the rising edge of the word clock.



图 27. Timing Diagram for I²S Mode



图 28. Timing Diagram for I²S Mode with ASI_OFFSET1 = 2

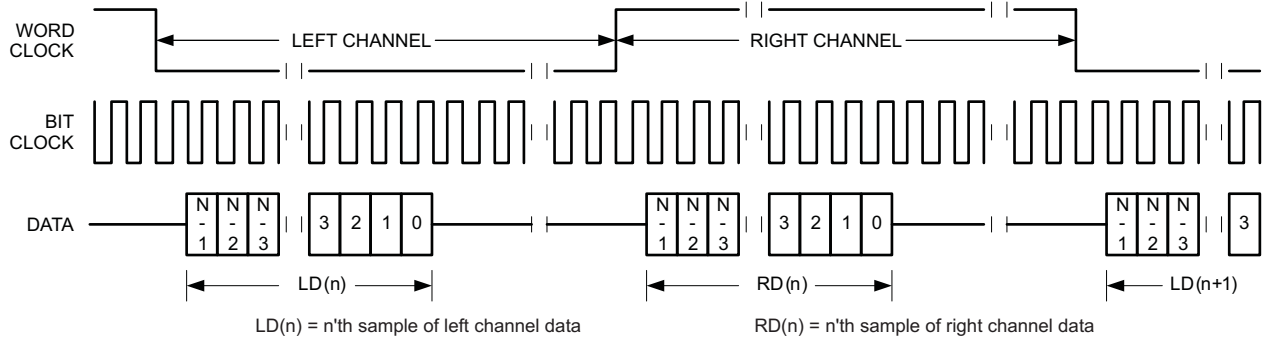

图 29. Timing Diagram for I²S Mode with ASI_OFFSET1 = 0 and Inverted Bit Clock

For I²S mode, the number of bit-clcks per channel should be greater than or equal to the programmed word-length of the data. Also the programmed offset value should be less than the number of bit-clcks per frame by at least the programmed word-length of the data.

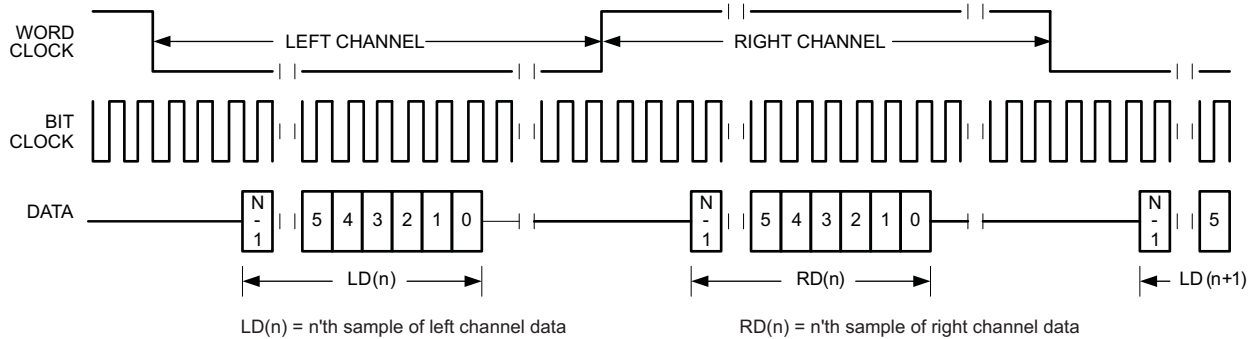
10.4.1.2 DSP Mode

In DSP mode, the rising edge of the word clock starts the data transfer with the left channel data first and immediately followed by the right channel data. Each data bit is valid on the falling edge of the bit clock.

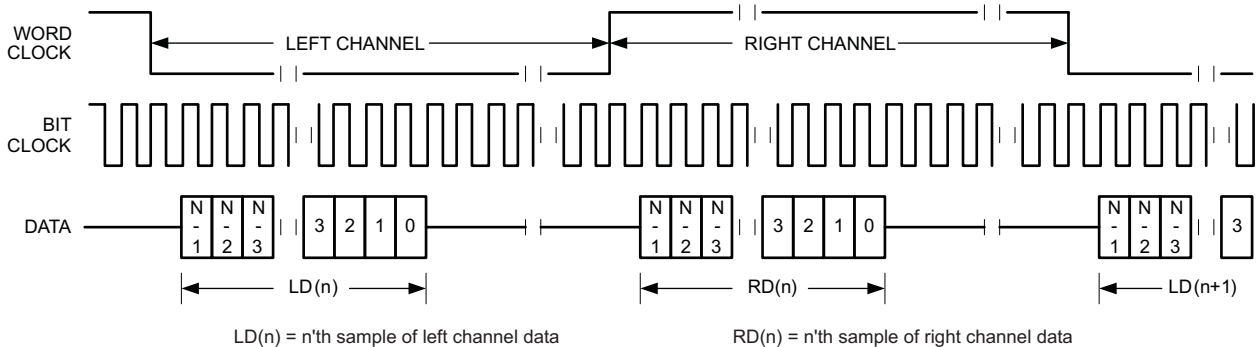

图 30. Timing Diagram for DSP Mode



图 31. Timing Diagram for DSP Mode with ASI_OFFSET1=1

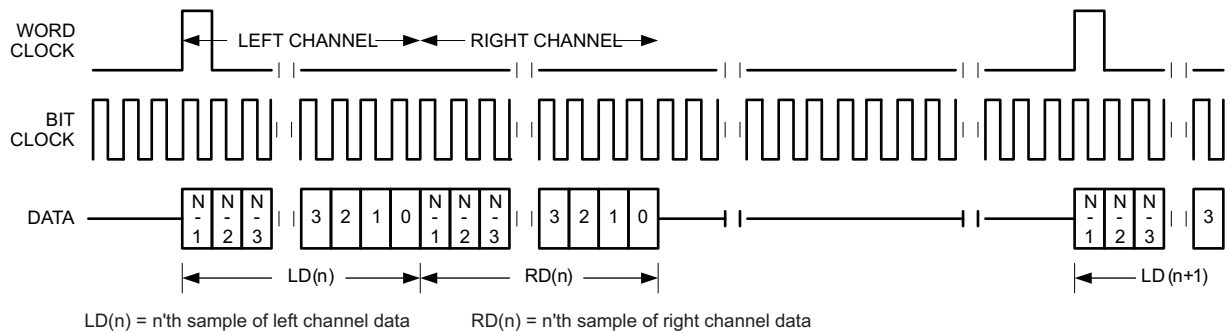

图 32. Timing Diagram for DSP Mode with ASI_OFFSET1=0 and Inverted Bit Clock

For DSP mode, the number of bit-clcks per frame should be greater than twice the programmed word-length of the data. Also the programmed offset value should be less than the number of bit-clcks per frame by at least the programmed word-length of the data.

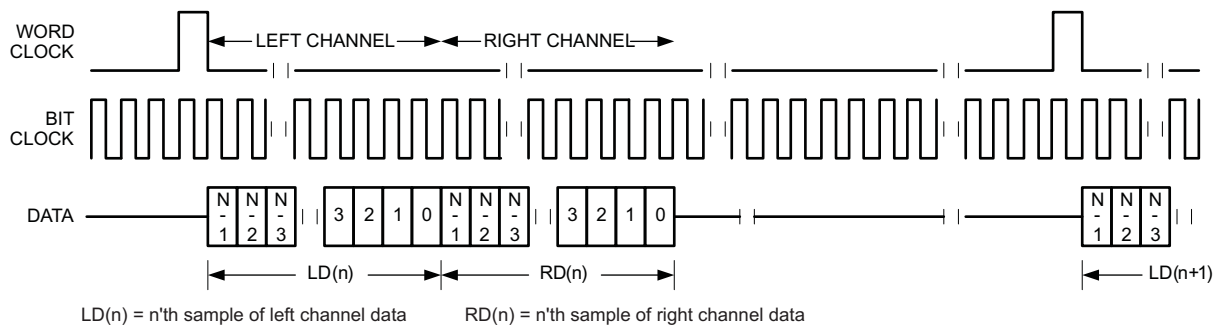
10.4.1.3 Right-Justified Mode (RJF)

In right-justified mode, the LSB of the left channel is valid on the rising edge of the bit clock preceding the falling edge of the word clock. Similarly, the LSB of the right channel is valid on the rising edge of the bit clock preceding the rising edge of the word clock.

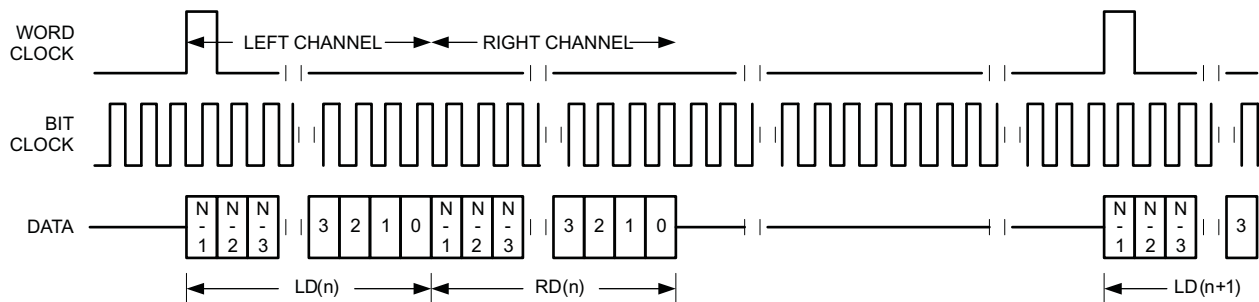

图 33. Timing Diagram for Right-Justified Mode

For right-justified mode, the number of bit-clocks per frame should be greater than twice the programmed word-length of the data.

10.4.1.4 Left-Justified Mode (LJF)

In left-justified mode, the MSB of the right channel is valid on the rising edge of the bit clock following the falling edge of the word clock. Similarly the MSB of the left channel is valid on the rising edge of the bit clock following the rising edge of the word clock.

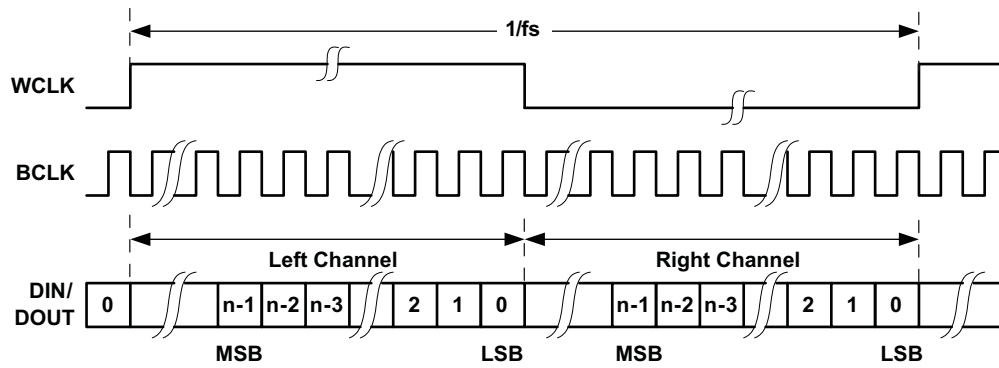

图 34. Timing Diagram for Left-Justified Mode



图 35. Timing Diagram for Light-Left Mode with ASI_OFFSET1 = 1

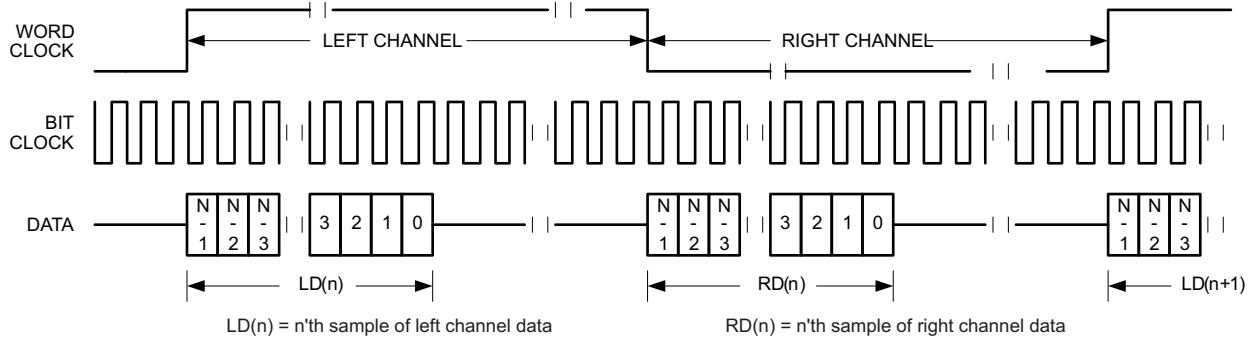

图 36. Timing Diagram for Left-Justified Mode with ASI_OFFSET1 = 0 and Inverted Bit Clock

For left-justified mode, the number of bit-clcks per frame should be greater than twice the programmed word-length of the data. Also, the programmed offset value should be less than the number of bit-clcks per frame by at least the programmed word-length of the data.

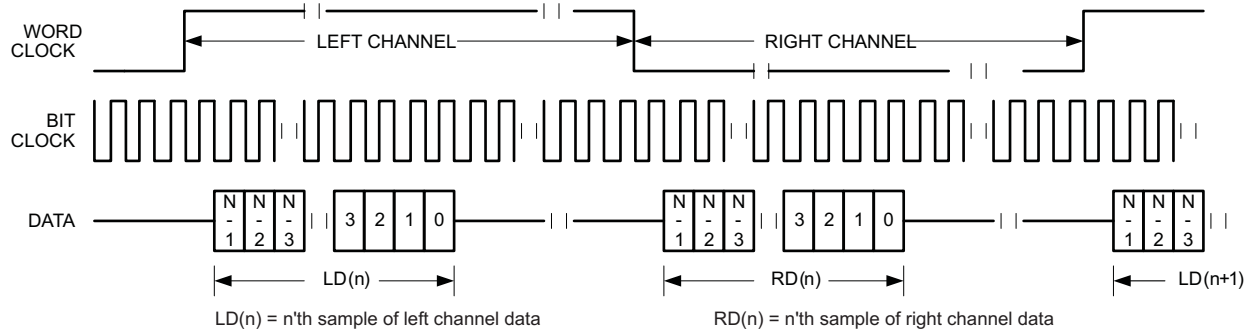
10.4.2 Mono PCM Mode

In mono PCM mode, the rising edge of the word clock starts the data transfer of the single channel of data. Each data bit is valid on the falling edge of the bit clock.

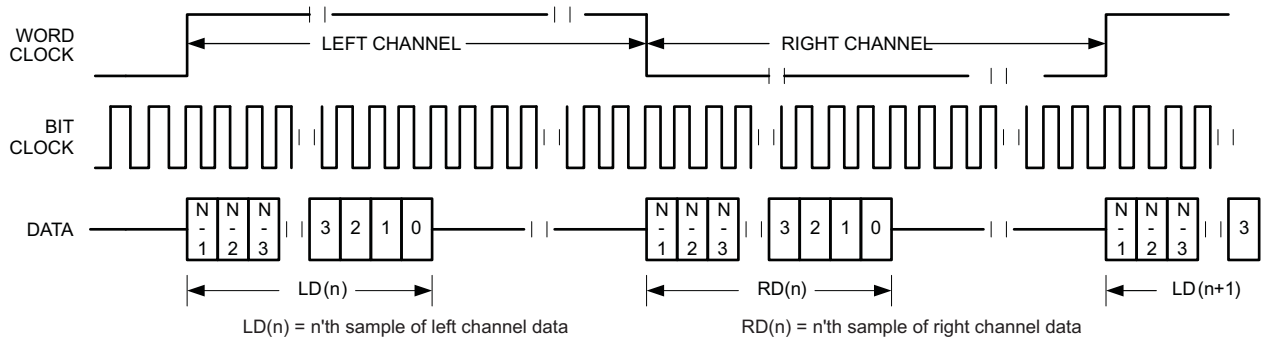

图 37. Timing Diagram for Mono PCM Mode



图 38. Timing Diagram for Mono PCM Mode with ASI_OFFSET1=2

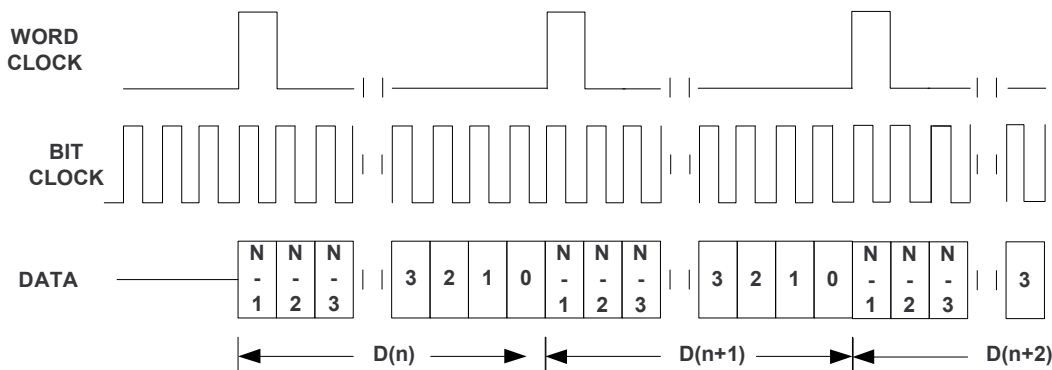

图 39. Timing Diagram for Mono PCM Mode with ASI_OFFSET1=2 and Bit Clock Inverted

For mono PCM mode, the programmed offset value should be less than the number of bit-clcks per frame by at least the programmed word-length of the data.

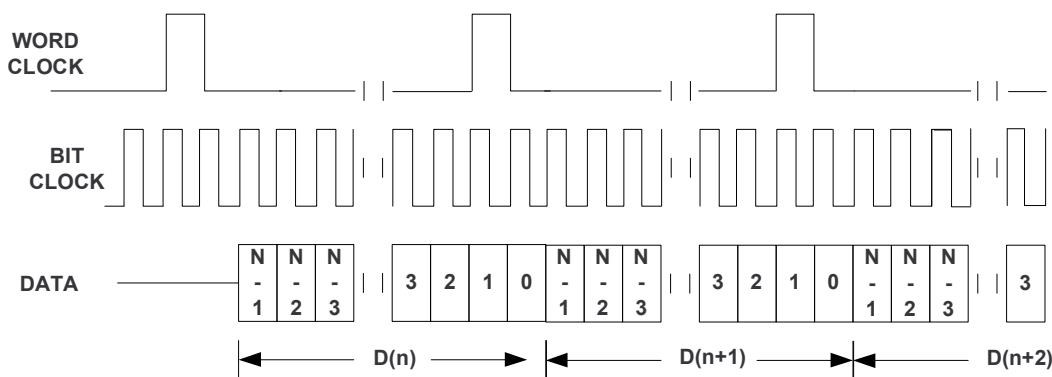
10.4.3 Stereo Application Example - TDM Mode

Time-division multiplexing (TDM) is required for two or more devices to share a common DIN connection and a common DOUT connection. Using TDM mode, all devices transmit their DOUT data in user-specified sub-frames within one WCLK period. When one device transmits its DOUT information, the other devices place their DOUT terminals in a high impedance tri-state mode. The host processor can operate in I²S mode while the TAS2557 is running in I²S TDM mode to support sharing of the same DOUT line.

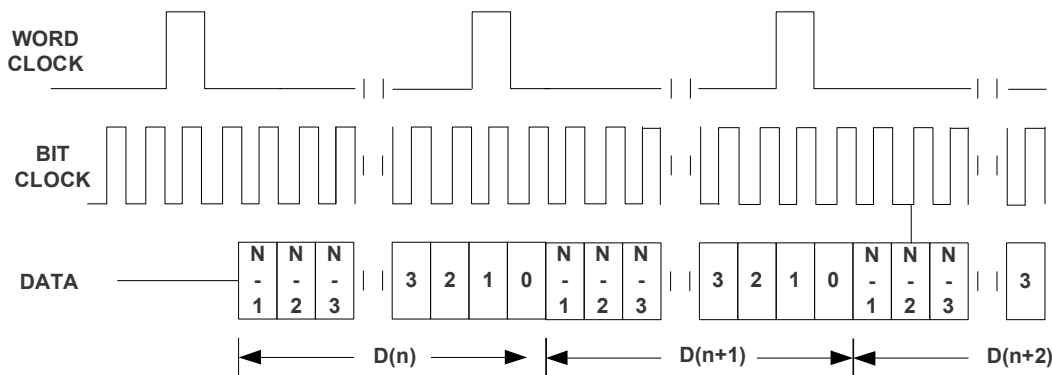
TDM mode is useable with I²S, LJF, RJF, and DSP interface modes. Refer to the respective sections for a description of how to set the TAS2557 into those modes.



图 40. Timing Diagram for I²S in TDM Mode with ASI_OFFSET1=2

For TDM mode, the number of bit-clcks per frame should be less than the programmed word-length of the data. Also the programmed offset value should be less than the number of bit-clcks per frame by at least the programmed word-length of the data.

10.5 Operational Modes

10.5.1 Hardware Shutdown

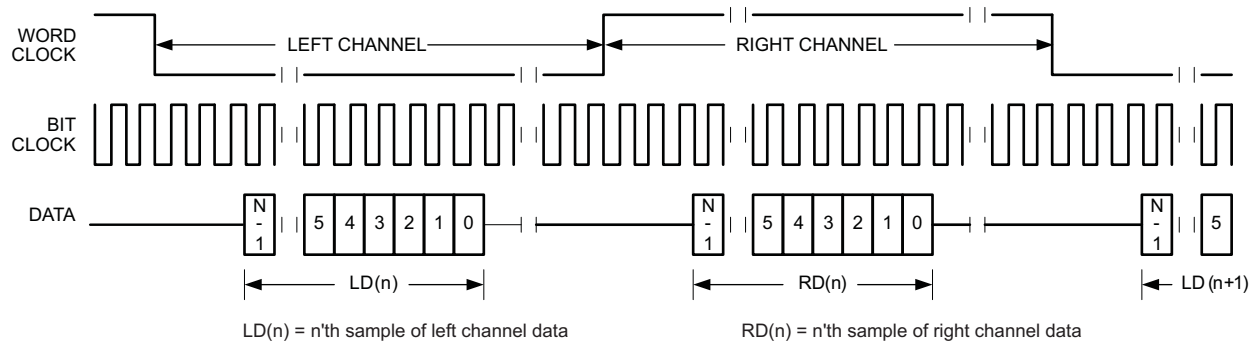
The device enters hardware shutdown mode if the RESETZ pin is asserted low. In hardware shutdown mode, the device consumes the minimum quiescent current from VDD and VBAT supplies. All registers loose state in this mode and I²C communication is disabled.

If RESETZ is asserted low while audio is playing, the device immediately stops operation and enters hardware shutdown mode. This may result in pops or clicks. It is recommend to first enter software shutdown before entering hardware shutdown.

When RESETZ is released, the device will enter software shutdown. A power up sequence such as with the appropriate mode selected should be executed to exit shutdown in the desired mode of operation.

10.5.2 Software Shutdown

Software shutdown mode powers down all analog blocks required to playback audio, but does not cause the device to lose register state. Software shutdown is enabled by following [Device Power Up and Unmute Sequence](#).

10.5.3 Low Power Sleep

The device has a low power sleep (表 20) mode option to reduce the power consumption on analog supply VBAT. In order to use this operating mode, the VBAT and AVDD supply should remain powered up when in this mode. This mode disables the Power-on Reset connected to the VBAT supply reducing current consumption.

表 20. Low Power Sleep

LOW_PWR[7] (VBAT_POR)	Low Power Sleep Mode
0	Disabled (default)
1	Enabled - VBAT POR shutdown

10.5.4 Software Reset

The TAS2557 internal logic must be initialized to a known condition for proper device function by doing a software reset. Performing software reset after a hardware reset is mandatory for reliable device boot up. A software reset can be accomplished by asserting RESET bit in 表 21, which is self clearing. This will restore all registers to their default values. After software reset is performed, no register read/write should be performed within 100us while initialization sequence occurs.

表 21. Software Reset

RESET[0] (RESET)	Action
0	Don't reset (default)
1	Reset(Self clearing)

10.5.5 Device Processing Modes

The TAS2557 DSP can be initialized into one of three modes. The advanced processing features in these modes, such as battery guard, thermal fold-back, brownout, and boost are configured using [PurePath™ Console 3 Software TAS2557 Application](#)

表 22. Device Power Mode

BOOT_MODE[3:0] (DSP_MODE)	Operating Mode
0000	Reserved
0001	Mode 1 - PCM input playback only (default)
0010	Mode 2 - PCM input playback + PCM IVsense output
0011	Mode 3 - Smart Amp Mode

10.5.5.1 Mode 1 - PCM input playback only

ROM mode 1 provides the quickest initialization for the TAS2557 power up and is the lowest power mode. This mode can be used to play a known power up audio sequence before the rest of the audio system software is loaded. The mode provides fault protection, brownout protection, volume control, and Class-H controller. The EQ and Battery Guard can be enabled with minimal additional configuration. The speaker protection algorithm is not running in this mode and the I/V sense ADCs are powered down to minimize power consumption. The PLL can be disabled for even lower power consumption if the MCLK supplied is at least 12.288MHz for any fs which is multiple or sub-multiple of 48kHz, or 11.2896 MHz for Fs of 44.1kHz. This mode should be used to characterize the electrical performance on the TAS2557 without any influence from the protection algorithm present in other modes.



图 41. ROM Mode 1 Processing Block Diagram

10.5.5.2 Mode 2 - PCM input playback + PCM IVsense output

ROM mode 2 is similar to ROM mode 1 except the I/V sense ADCs are powered up and the data is routed back on the L/R return channels of the ASI port. This mode can be used to return the I/V data to the host and perform alternate computations on the speaker I/V measurements.

图 42. ROM Mode 2 Processing Block Diagram

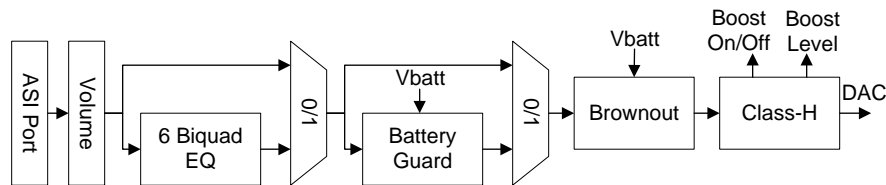
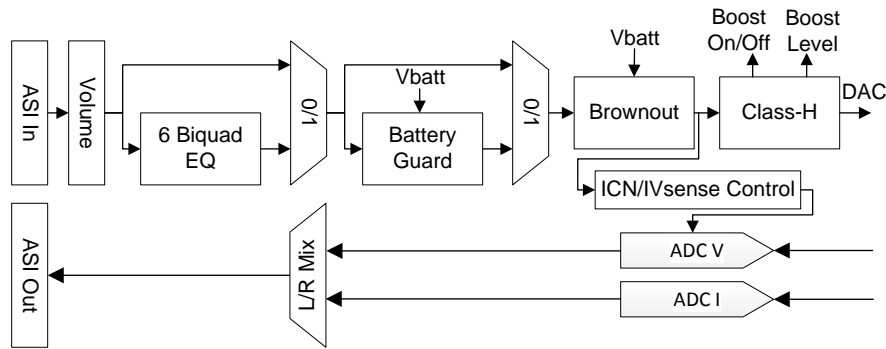
10.5.5.3 Mode 3 - Smart Amp Mode

Smart Amp Mode is used to run the TI Smart Amp algorithm on the built in DSP. This mode involves loading larger output files generated from the [PurePath™ Console 3 Software TAS2557 Application](#). The generated files contain the speaker models, equalization, and additional configuration parameters in a format to load over the I²C or SPI interface. TI's Smart Amp provides thermal and excursion protection using initial speaker models and the current and voltage feedback. This allows TAS2557 to determine exact coil temperature and update the initial model due to variations in speaker and ambient conditions. More information about this mode can be found in the [PurePath™ Console 3 Software TAS2557 Application](#).

10.6 Programming

While the below scripts are provided as configuration examples, it is recommended to use [PurePath™ Console 3 Software TAS2557 Application](#) software to generate the device configuration files. This software contains configuration checks to ensure proper settings are used in the device for various cases and loaded the needed fixed-function DSP patches.

10.6.1 Code Loading and CRC check

The TI Smart Amp software is loaded into program ram (PRAM) through writes to mapped memory registers. The encrypted binary software is downloaded and decoded on chip. Therefore read-back of the PRAM is disabled. However an 8-bit CRC checksum is provided to the customer to verify the code was correctly written to PRAM error-free. Once the software download is complete, the calculated 8-bit CRC checksum can be read from register CRC_CHECKSUM. If this value matches the checksum supplied with the program, the load to PRAM was successful. If new PRAM code is loaded the TAS2557 device should first be software or hardware reset to clear the CRC checksum register so that a proper checksum from the new code to be loaded.

Programming (接下页)

The following is an example script used to load the DSP software and verify the CRC checksum.

```
#####
#This script is a demo for downloading the PRAM code and checking CRC checksum
i i2cstd
#mclk expected is 24.576 MHz
#configuring device registers for 8 ohm speaker load
##### DEVICE INIT SEQ START#####
w 98 00 00 #Page-0
w 98 7f 00 #Book-0
w 98 01 01 #Software reset
d 1      # wait 100us time for OTP-One Time Programmable memory values to be transferred to device

##### INIT SECTION START
w 98 7f 64 # book 100
w 98 46 01 # IRAM boot
w 98 7f 00 # book 0
##### INIT SECTION END

##### DSP PROG SETTING START
w 98 7f 64
w 98 00 01
#add writes for download to PRAM here
w 98 00 00
w 98 7f 00
##### DSP PROG SETTING END

##### DEVICE INIT SEQ END #####

r 98 20 1 # reading the CRC checksum for the PRAM download , if read = CRC checksum provided to
customer => PRAM download success

##### CHANNEL POWER UP #####
w 98 05 A3 # Power up Analog Blocks
w 98 04 B8 # Power up DSP and clock dividers
w 98 07 00 # Unmute Analog Blocks
w 98 7f 64 # switch to book100
w 98 07 00 # Soft stepped unmute of audio playback
#####

##### DSP coeff update START
# d 1
# DSP filter coefficient update if required
##### DSP coeff update END

#####device powered up and running#####

##### CHANNEL POWER DOWN #####
w 98 07 01 # Soft stepped mute of audio playback
d 10      # wait for DSP to mute classD after soft step down of audio
# instead of delay alternatively status flag B120_P15_R120_R121_R122_R123 polling can be done and wait
till R122_D0 = '1'.
w 98 7f 00 # switch to book0
w 98 07 03 # Mute Analog Blocks
w 98 04 20 # Power down DSP and clock dividers (except Ndivider)
w 98 05 00 # Power down Analog Blocks
w 98 00 00 # NOP
w 98 04 00 # Power down Ndivider
#####
#optional(ending the script in B0_P0)
w 98 00 00 # page 0
w 98 7f 00 # book 0
#####
```

Programming (接下页)

10.6.2 Device Power Up and Unmute Sequence

The following code example provide the correct sequence to power up and unmute the device. The [PurePath™ Console 3 Software TAS2557 Application](#) software will create output files with these commands. The following is a example of powering up the part in DSP Mode 2 with proper sequencing.

```

Example script (ROM Mode 2):
#####
i i2cstd
#mclk expected is 24.576 MHz
#configuring device registers for 8 ohm speaker load
##### DEVICE INIT SEQ START#####
w 98 00 00 #Page-0
w 98 7f 00 #Book-0
w 98 01 01 #Software reset
d 1      # wait 100us time for OTP-One Time Programmable memory values to be transferred to device

##### DSP PROG SETTING START
w 98 22 22 # use default coefficients and operate DSP in rom mode 2
##### DSP PROG SETTING END

##### DEVICE INIT SEQ END #####

##### CHANNEL POWER UP #####
w 98 05 A3 # Power up Analog Blocks
w 98 04 B8 # Power up DSP and clock dividers
w 98 07 00 # Unmute Analog Blocks
w 98 7f 64 # switch to book100
w 98 07 00 # Soft stepped unmute of audio playback
#####

##### DSP coeff update START
# d 1
# DSP filter coefficient update if required
##### DSP coeff update END

b #####device powered up and running#####
  
```

Programming (接下页)

10.6.3 Device Mute and Power Down Sequence

The following code example provide the correct sequence to mute and power down the device. The [PurePath™ Console 3 Software TAS2557 Application](#) software will create output files with these commands.

Example script (ROM Mode 2):

```
#####
i i2cstd
#####          CHANNEL POWER DOWN #####
w 98 07 01 # Soft stepped mute of audio playback
d 10      # wait for DSP to mute classD after soft step down of audio
# instead of delay alternatively status flag B120_P15_R120_R121_R122_R123 polling can be done and wait
till R122_D0 = '1'.
w 98 7f 00 # switch to book0
w 98 07 03 # Mute Analog Blocks
w 98 04 20 # Power down DSP and clock dividers (except Ndivider)
w 98 05 00 # Power down Analog Blocks
w 98 00 00 # NOP
w 98 04 00 # Power down Ndivider
#####
#optional(ending the script in B0_P0)
w 98 00 00 # page 0
w 98 7f 00 # book 0
#####
```

11 Applications and Implementation

注

Information in the following applications sections is not part of the TI component specification, and TI does not warrant its accuracy or completeness. TI's customers are responsible for determining suitability of components for their purposes. Customers should validate and test their design implementation to confirm system functionality.

11.1 Application Information

The TAS2557 is a digital input high efficiency Class-D audio power amplifier with advanced battery current management and an integrated Class-H boost converter. In auto-passthrough mode, the Class-H boost converter generates the Class-D amplifier supply rail. During low Class-D output power, the boost improves efficiency by deactivating and connecting VBAT directly to the Class-D amplifier supply. When high power audio is required, the boost quickly activates to provide louder audio than a stand-alone amplifier connected directly to the battery. To enable load monitoring, the TAS2557 constantly measures the current and voltage across the load and provides a digital stream of this information back to a processor.

11.2 Typical Applications



图 43. Typical Application - Digital Audio Input

Typical Applications (接下页)

表 23. Recommended External Components

COMPONENT	DESCRIPTION	SPECIFICATION	MIN	TYP	MAX	UNIT
L1	Boost Converter Inductor	Inductance, 20% Tolerance	1	2.2		μH
		Saturation Current		3.1		A
L2, L3	EMI Filter Inductors (optional). These are not recommended as it degrades THD+N performance. The TAS2557 device is a filter-less Class-D and does not require these bead inductors.	Impedance at 100MHz		120		Ω
		DC Resistance			0.095	Ω
		DC Current			2	A
		Size		0402		EIA
C1	Boost Converter Input Capacitor	Capacitance, 20% Tolerance	10			μF
C2	Boost Converter Output Capacitor	Type	X5R			
		Capacitance, 20% Tolerance	22		47	μF
		Rated Voltage	16			V
		Capacitance at 8.5 V derating	3.3			μF
C3, C4	EMI Filter Capacitors (optional, must use L2, L3 if C3, C4 used)	Capacitance		1		nF

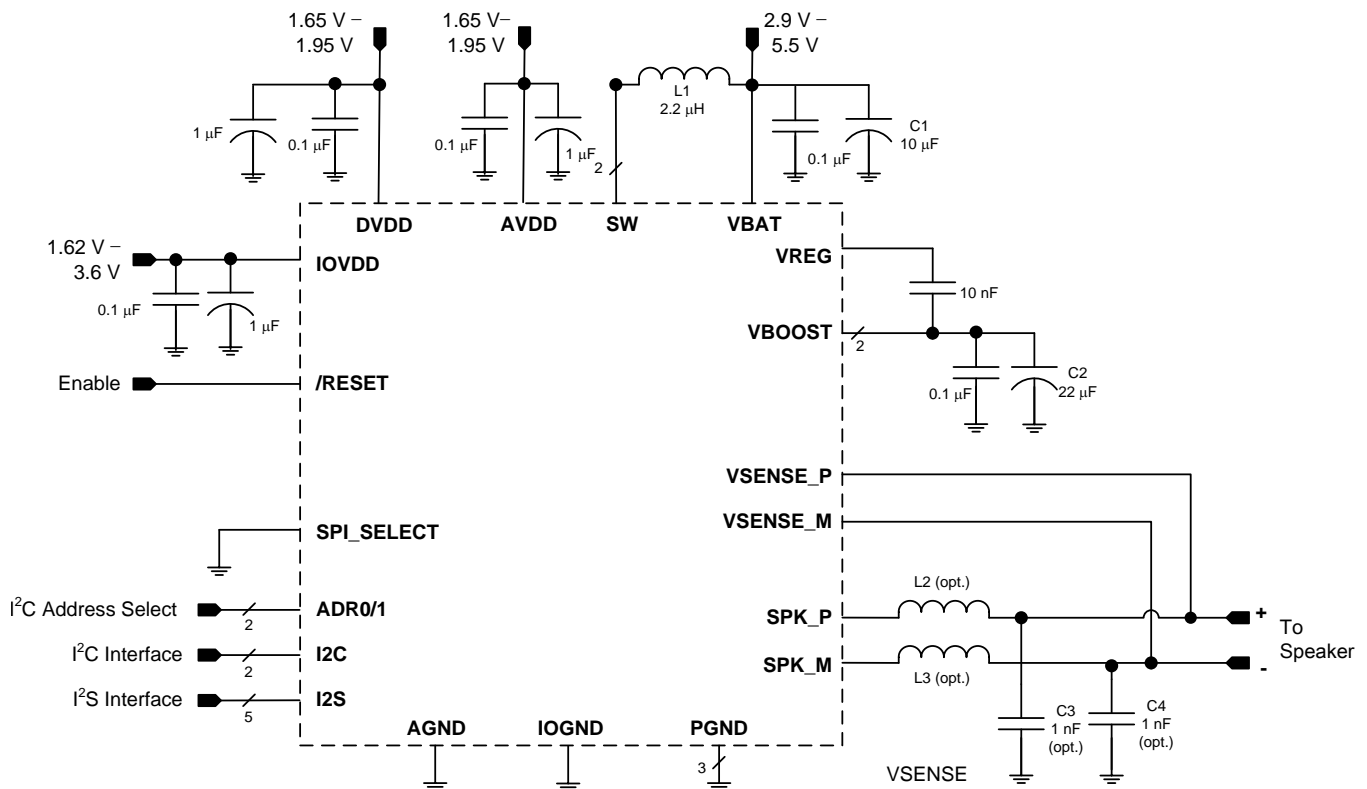
11.2.1 Design Requirements

For this design example, use the parameters shown in [表 24](#).

表 24. Design Parameters

DESIGN PARAMETER	EXAMPLE VALUE
Audio Input	Digital Audio, I ² S
Current and Voltage Data Stream	Digital Audio, I ² S
Mono or Stereo Configuration	Mono
Max Output Power at 1% THD+N	3.8 W

11.2.1.1 Detailed Design Procedure

11.2.1.1.1 Mono/Stereo Configuration

In this application, the device is assumed to be operating in mono mode. See [General I²C Operation](#) for information on changing the I²C address of the TAS2557 to support stereo operation. Mono or stereo configuration does not impact the device performance.

11.2.1.1.2 Boost Converter Passive Devices

The boost converter requires three passive devices that are labeled L1, C1 and C2 in [图 43](#) and whose specifications are provided in [表 23](#). These specifications are based on the design of the TAS2557 and are necessary to meet the performance targets of the device. In particular, L1 should not be allowed to enter in the current saturation region. The saturation current for L1 should be > I_{LIM} to deliver Class-D peak power.

Additionally, the ratio of L1/C2 (the derated value of C2 at 8.5 V should be used in this ratio) has to be lesser than 1/3 for boost stability. This 1/3 ratio should be maintained including the worst case variation of L1 and C2. To satisfy sufficient energy transfer, L1 needs to be ≥ 1μH at the boost switching frequency (~1.7 MHz). Using a 1μH will have more boost ripple than a 2.2μH but the PSRR should minimize the effect from the additional ripple. Finally, the minimum C2 (derated value at 8.5 V) should be > 3.3μF for Class-D power delivery specification.

11.2.1.1.3 EMI Passive Devices

The TAS2557 supports edge-rate control to minimize EMI, but the system designer may want to include passive devices on the Class-D output devices. These passive devices that are labeled L2, L3, C3 and C4 in [图 43](#) and their recommended specifications are provided in [表 23](#). If C3 and C4 are used, they must be placed after L2 and L3 respectively to maintain the stability of the output stage.

11.2.1.1.4 Miscellaneous Passive Devices

- VREG Capacitor: Needs to be 10 nF to meet boost and Class-D power delivery and efficiency specs.

11.2.2 Application Performance Plots

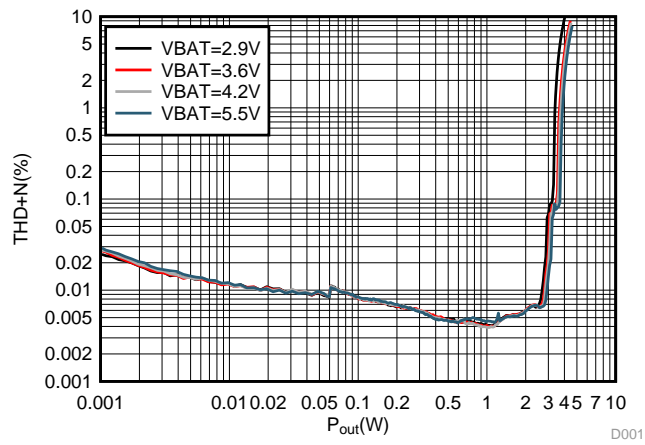

Freq = 1kHz VBAT = 3.6 V, AVDD = IOVDD = 1.8 V, $\overline{\text{RESET}} = \text{IOVDD}$, $R_L = 8 \Omega + 33 \mu\text{H}$, I2S digital input, ROM mode 1

图 44. THD+N vs Output Power (8 Ω) for Digital Input

11.3 Initialization Set Up

To configure the TAS2557 , follow these steps.

1. Bring-up the power supplies as in [Power Supply Sequencing](#).
2. Set the /RESET terminal to HIGH.
3. Follow the software sequence in section [Device Power Up and Unmute Sequence](#)

12 Power Supply Recommendations

12.1 Power Supplies

The TAS2557 requires four power supplies:

- Boost Input (terminal: VBAT)
 - Voltage: 2.9 V to 5.5 V
 - Max Current: 5 A for ILIM = 3.0 A (default)
- Analog Supply (terminal: AVDD)
 - Voltage: 1.65 V to 1.95 V
 - Max Current: 30 mA
- Digital Supply (terminal: DVDD)
 - Voltage: 1.65 V to 1.95 V
 - Max Current: 50 mA
- Digital I/O Supply (terminal: IOVDD)
 - Voltage: 1.62 V to 3.6 V
 - Max Current: 5 mA

The decoupling capacitors for the power supplies should be placed close to the device terminals. For VBAT, IOVDD, DVDD and AVDD, a small decoupling capacitor of 0.1 μ F should be placed close to the device terminals. Refer to [图 43](#) for the schematic.

12.2 Power Supply Sequencing

The following power sequence should be followed for power up and power down. If the recommended sequence is not followed there can be large current in device due to faults in level shifters and diodes becoming forward biased. The T_{delay} between power supplies should be large enough for the power rails to settle.



图 45. Power Supply Sequence for Power-Up and Power-Down

When the supplies have settled, the /RESET terminal can be set HIGH to operate the device. Additionally the /RESET pin can be tied to IOVDD and the internal DVDD POR will perform a reset of the device. After a hardware or software reset additional commands to the device should be delayed for 100 μ s to allow the OTP to load. The above sequence should be completed before any I²C operation.

13 Layout

13.1 Layout Guidelines

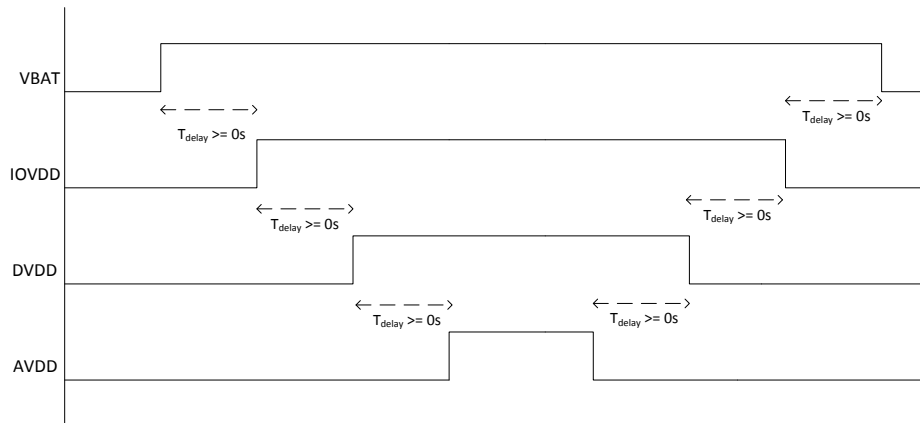
- Place the boost inductor between VBAT and SW close to device terminals with no VIAS between the device terminals and the inductor.
- Place the capacitor between VREG and VBOOST close to device terminals with no VIAS between the device terminals and capacitor.
- Place the capacitor between VBOOST/VBAT and GND close to device terminals with no VIAS between the device terminals and capacitor.
- Do not use VIAS for traces that carry high current. These include the traces for VBOOST, SW, VBAT, PGND and the speaker SPK_P, SPK_M.
- Use epoxy filled vias for the interior pads.
- Connect VSENSE+, VSENSE- as close as possible to the speaker.
 - VSENSE+, VSENSE- should be connected between the EMI ferrite filter and the speaker if EMI ferrites are used on SPK_P, SPK_M.
- Use a ground plane with multiple vias for each terminal to create a low-impedance connection to GND for minimum ground noise.
- Use supply decoupling capacitors as shown in [图 43](#) and described in [Power Supply Recommendations](#).
- Place EMI ferrites, if used, close to the device.

13.2 Layout Example



图 46. TAS2557 Board Layout

14 Register Map

See the General I²C Operation section for more details on addressing. Register settings should be set based on the files generated from the PPC3 GUI. Because the TAS2557 is a complex system including the internal software, changes made in the TAS2557 registers not known in the PPC3 generated configurations can result in the speaker protection not operating correctly. Changes should be made from within [PurePath™ Console 3 Software TAS2557 Application](#) instead of manually changing registers when possible. Configuration files with needed options can be generated from PPC3 to prevent invalid configurations.

14.1 Register Map Summary

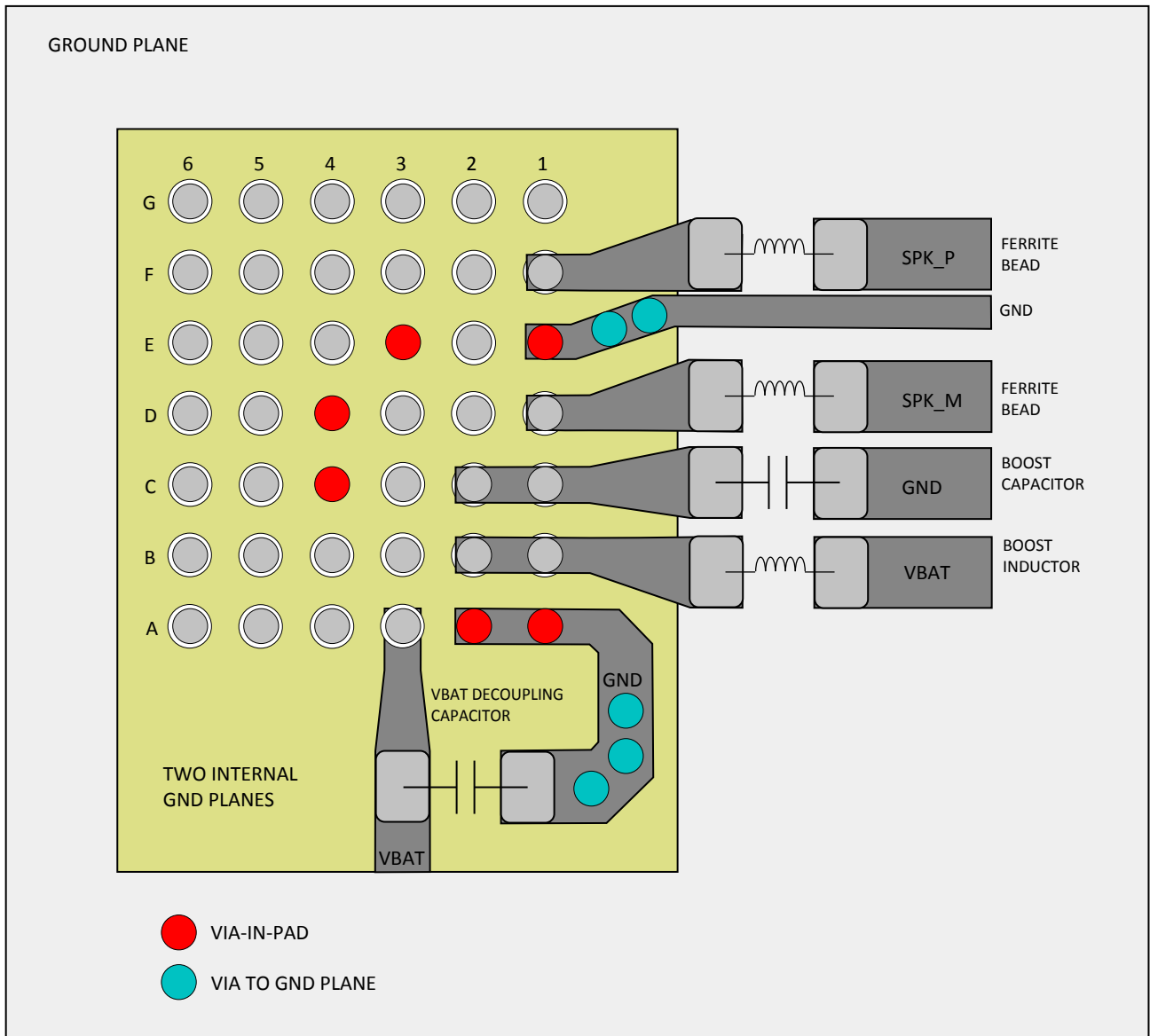
14.1.1 Register Summary Table Book=0x00 Page=0x00

Addr	Register	Description	Section
0x00	PAGE	Page Select	PAGE (book=0x00 page=0x02 address=0x00) [reset=1h]
0x01	RESET	Software Reset	RESET (book=0x00 page=0x00 address=0x01) [reset=0h]
0x04	POWER_1	Power Up 1	POWER_1 (book=0x00 page=0x00 address=0x04) [reset=0h]
0x05	POWER_2	Power Up 2	POWER_2 (book=0x00 page=0x00 address=0x05) [reset=0h]
0x06	SPK_GAIN_EDGE	Class-D Speaker Configuration	SPK_GAIN_EDGE (book=0x00 page=0x00 address=0x06) [reset=0h]
0x07	MUTE	Mute Configuration	MUTE (book=0x00 page=0x00 address=0x07) [reset=0h]
0x08	SNS_CTRL	Sense Channel Control	SNS_CTRL (book=0x00 page=0x00 address=0x08) [reset=0h]
0x09	BOOST_CTRL_1	Boost Control 1	BOOST_CTRL_1 (book=0x00 page=0x00 address=0x09) [reset=0h]
0x14	SAR_CTRL_2	SAR Control 2	SAR_CTRL_2 (book=0x00 page=0x00 address=0x14) [reset=32h]
0x15	SAR_CTRL_3	SAR Control 3	SAR_CTRL_3 (book=0x00 page=0x00 address=0x15) [reset=4h]
0x16	SAR_VBAT_MSB	SAR VBAT Readback	SAR_VBAT_MSB (book=0x00 page=0x00 address=0x16) [reset=0h]
0x17	SAR_VBAT_LSB	SAR VBAT Readback	SAR_VBAT_LSB (book=0x00 page=0x00 address=0x17) [reset=0h]
0x18	SAR_VBST_MSB	SAR VBOOST Readback	SAR_VBST_MSB (book=0x00 page=0x00 address=0x18) [reset=0h]
0x19	SAR_VBST_LSB	SAR VBOOST Readback	SAR_VBST_LSB (book=0x00 page=0x00 address=0x19) [reset=0h]
0x1A	SAR_TMP1_MSB	SAR TEMP1 Readback	SAR_TMP1_MSB (book=0x00 page=0x00 address=0x1A) [reset=0h]
0x1B	SAR_TMP1_LSB	SAR TEMP1 Readback	SAR_TMP1_LSB (book=0x00 page=0x00 address=0x1B) [reset=0h]
0x1C	SAR_TMP2_MSB	SAR TEMP2 Readback	SAR_TMP2_MSB (book=0x00 page=0x00 address=0x1C) [reset=0h]
0x1D	SAR_TMP2_LSB	SAR TEMP2 Readback	SAR_TMP2_LSB (book=0x00 page=0x00 address=0x1D) [reset=0h]
0x20	CRC_CHECKSUM	Checksum	CRC_CHECKSUM (book=0x00 page=0x00 address=0x20) [reset=0h]
0x21	CRC_RESET	Checksum Reset	CRC_RESET (book=0x00 page=0x00 address=0x21) [reset=0h]
0x22	DSP_CTRL	DSP Control	DSP_CTRL (book=0x00 page=0x00 address=0x22) [reset=1h]
0x28	SSM_CTRL	Spread-Spectrum Control	SSM_CTRL (book=0x00 page=0x00 address=0x28) [reset=0h]
0x2A	ASI_CTRL_1	ASI Control 1	ASI_CTRL_1 (book=0x00 page=0x00 address=0x2A) [reset=0h]
0x2B	BOOST_CTRL_2	Boost Control 1	BOOST_CTRL_2 (book=0x00 page=0x00 address=0x2B) [reset=3h]
0x2C	CLOCK_CTRL_1	Clock Control 1	CLOCK_CTRL_1 (book=0x00 page=0x00 address=0x2C) [reset=0h]
0x2D	CLOCK_CTRL_2	Clock Control 2	CLOCK_CTRL_2 (book=0x00 page=0x00 address=0x2D) [reset=17h]
0x2E	CLOCK_CTRL_3	Clock Control 3	CLOCK_CTRL_3 (book=0x00 page=0x00 address=0x2E) [reset=0h]
0x2F	ASI_CTRL_2	ASI Control 2	ASI_CTRL_2 (book=0x00 page=0x00 address=0x2F) [reset=0h]

Register Map Summary (continued)

0x32	CLOCK_CTRL_4	Clock Control 4	CLOCK_CTRL_4 (book=0x00 page=0x00 address=0x32) [reset=0h]
0x35	DEBUG_1	Debug Register 1	DEBUG_1 (book=0x00 page=0x00 address=0x35) [reset=0h]
0x64	POWER_STATUS	Power Up Status	POWER_STATUS (book=0x00 page=0x00 address=0x64) [reset=0h]
0x65	DSP_BOOT_STATUS	DSP Boost Status	DSP_BOOT_STATUS (book=0x00 page=0x00 address=0x65) [reset=0h]
0x68	INT_DET_1	Interrupt Detected 1	INT_DET_1 (book=0x00 page=0x00 address=0x68) [reset=0h]
0x6C	INT_DET_2	Interrupt Detected 2	INT_DET_2 (book=0x00 page=0x00 address=0x6C) [reset=0h]
0x79	LOW_POWER	Lower Power Shutdown	LOW_POWER (book=0x00 page=0x00 address=0x79) [reset=0h]
0x7F	BOOK	Book Selection	BOOK (book=0x00 page=0x00 address=0x7F) [reset=0h]

14.1.2 Register Summary Table Book=0x00 Page=0x01

Addr	Register	Description	Section
0x00	PAGE	Page Select	PAGE (book=0x00 page=0x02 address=0x00) [reset=1h]
0x01	ASI1_FORMAT	ASI1 Format	ASI1_FORMAT (book=0x00 page=0x01 address=0x01) [reset=10h]
0x03	ASI1_OFFSET_1	ASI1 Offset	ASI1_OFFSET_1 (book=0x00 page=0x01 address=0x03) [reset=0h]
0x04	ASI1_OFFSET_2	ASI1 Offset Second Slot	
0x05	ASI1_BUSKEEP	ASI1 Buskeeper	ASI1_BUSKEEP (book=0x00 page=0x01 address=0x05) [reset=0h]
0x08	ASI1_BCLK	ASI1 BCLK	ASI1_BCLK (book=0x00 page=0x01 address=0x08) [reset=0h]
0x09	ASI1_WCLK	ASI1 WCLK	ASI1_WCLK (book=0x00 page=0x01 address=0x09) [reset=8h]
0x0C	ASI1_DIN_DOUT	ASI1 DIN/DOU	ASI1_DIN_DOUT (book=0x00 page=0x01 address=0x0C) [reset=0h]
0x0D	ASI1_BDIV_CLK	ASI1 BDIV Clock	ASI1_BDIV_CLK (book=0x00 page=0x01 address=0x0D) [reset=1h]
0x0E	ASI1_BDIV_RATIO	ASI1 BDIV Ratio	ASI1_BDIV_RATIO (book=0x00 page=0x01 address=0x0E) [reset=2h]
0x0F	ASI1_WDIV_RATIO	ASI1 WDIV Ratio	ASI1_WDIV_RATIO (book=0x00 page=0x01 address=0x0F) [reset=20h]
0x10	ASI1_CLK_OUT	ASI1 Clock Source	ASI1_CLK_OUT (book=0x00 page=0x01 address=0x10) [reset=0h]
0x15	ASI2_FORMAT	ASI2 Format	ASI2_FORMAT (book=0x00 page=0x01 address=0x15) [reset=10h]
0x17	ASI2_OFFSET_1	ASI2 Offset	ASI2_OFFSET_1 (book=0x00 page=0x01 address=0x17) [reset=0h]
0x18	ASI2_OFFSET_2	ASI2 Offset Second Slot	
0x19	ASI2_BUSKEEP	ASI2 Buskeeper	ASI2_BUSKEEP (book=0x00 page=0x01 address=0x19) [reset=0h]
0x1C	ASI2_BCLK	ASI2 BCLK	ASI2_BCLK (book=0x00 page=0x01 address=0x1C) [reset=20h]
0x1D	ASI2_WCLK	ASI2 WCLK	ASI2_WCLK (book=0x00 page=0x01 address=0x1D) [reset=28h]
0x20	ASI2_DIN_DOUT	ASI2 DIN/DOU	ASI2_DIN_DOUT (book=0x00 page=0x01 address=0x20) [reset=38h]
0x21	ASI2_BDIV_CLK	ASI2 BDIV Clock	ASI2_BDIV_CLK (book=0x00 page=0x01 address=0x21) [reset=1h]
0x22	ASI2_BDIV_RATIO	ASI2 BDIV Ratio	ASI2_BDIV_RATIO (book=0x00 page=0x01 address=0x22) [reset=2h]
0x23	ASI2_WDIV_RATIO	ASI2 WDIV Ratio	ASI2_WDIV_RATIO (book=0x00 page=0x01 address=0x23) [reset=20h]
0x24	ASI2_CLK_OUT	ASI2 Clock Source	ASI2_CLK_OUT (book=0x00 page=0x01 address=0x24) [reset=33h]
0x3D	GPIO1_PIN	GPIO1	GPIO1_PIN (book=0x00 page=0x01 address=0x3D) [reset=1h]

TAS2557

ZHCSFP7A – NOVEMBER 2016 – REVISED FEBRUARY 2017

www.ti.com.cn

0x3E	GPIO2_PIN	GPIO2	GPIO2_PIN (book=0x00 page=0x01 address=0x3E) [reset=1h]
0x3F	GPIO3_PIN	GPIO3	GPIO3_PIN (book=0x00 page=0x01 address=0x3F) [reset=10h]
0x40	GPIO4_PIN	GPIO4	GPIO4_PIN (book=0x00 page=0x01 address=0x40) [reset=7h]
0x41	GPIO5_PIN	GPIO5	GPIO5_PIN (book=0x00 page=0x01 address=0x41) [reset=0h]
0x42	GPIO6_PIN	GPIO6	GPIO6_PIN (book=0x00 page=0x01 address=0x42) [reset=0h]
0x43	GPIO7_PIN	GPIO7	GPIO7_PIN (book=0x00 page=0x01 address=0x43) [reset=0h]
0x44	GPIO8_PIN	GPIO8	GPIO8_PIN (book=0x00 page=0x01 address=0x44) [reset=0h]
0x45	GPIO9_PIN	GPIO9	GPIO9_PIN (book=0x00 page=0x01 address=0x45) [reset=0h]
0x46	GPIO10_PIN	GPIO10	GPIO10_PIN (book=0x00 page=0x01 address=0x46) [reset=0h]
0x4D	GPI_PIN	GPI Pin Mode	GPI_PIN (book=0x00 page=0x01 address=0x4D) [reset=0h]
0x4F	GPIO_HIZ_1	GPIO HiZ 1	GPIO_HIZ_1 (book=0x00 page=0x01 address=0x4F) [reset=0h]
0x50	GPIO_HIZ_2	GPIO HiZ 2	GPIO_HIZ_2 (book=0x00 page=0x01 address=0x50) [reset=0h]
0x51	GPIO_HIZ_3	GPIO HiZ 3	GPIO_HIZ_3 (book=0x00 page=0x01 address=0x51) [reset=0h]
0x52	GPIO_HIZ_4	GPIO HiZ 4	GPIO_HIZ_4 (book=0x00 page=0x01 address=0x52) [reset=0h]
0x53	GPIO_HIZ_5	GPIO HiZ 5	GPIO_HIZ_5 (book=0x00 page=0x01 address=0x53) [reset=0h]
0x58	BIT_BANG_OUT1	Bit Bang Output 1	BIT_BANG_OUT1 (book=0x00 page=0x01 address=0x58) [reset=0h]
0x59	BIT_BANG_OUT2	Bit Bang Output 2	BIT_BANG_OUT2 (book=0x00 page=0x01 address=0x59) [reset=0h]
0x5A	BIT_BANG_IN1	Bit Bang Input 1	BIT_BANG_IN1 (book=0x00 page=0x01 address=0x5A) [reset=0h]
0x5B	BIT_BANG_IN2	Bit Bang Input 2	BIT_BANG_IN2 (book=0x00 page=0x01 address=0x5B) [reset=0h]
0x5C	BIT_BANG_IN3	Bit Bang Input 3	BIT_BANG_IN3 (book=0x00 page=0x01 address=0x5C) [reset=0h]
0x60	ASIM_BUSKEEP	ASIM Buskeeper	ASIM_BUSKEEP (book=0x00 page=0x01 address=0x60) [reset=0h]
0x61	ASIM_MODE	ASIM Mode	ASIM_MODE (book=0x00 page=0x01 address=0x61) [reset=8h]
0x62	ASIM_NUM_DEV	ASIM Number Devices	ASIM_NUM_DEV (book=0x00 page=0x01 address=0x62) [reset=0h]
0x63	ASIM_FORMAT	ASIM Format	ASIM_FORMAT (book=0x00 page=0x01 address=0x63) [reset=10h]
0x64	ASIM_BDIV_CLK	ASIM BDIV Clock	ASIM_BDIV_CLK (book=0x00 page=0x01 address=0x64) [reset=1h]
0x65	ASIM_BDIV_RATIO	ASIM BDIV Ratio	ASIM_BDIV_RATIO (book=0x00 page=0x01 address=0x65) [reset=2h]
0x66	ASIM_WDIV_RATIO_1	ASIM WDIV Ratio	ASIM_WDIV_RATIO_1 (book=0x00 page=0x01 address=0x66) [reset=0h]
0x67	ASIM_WDIV_RATIO_2	ASIM WDIV Ratio	ASIM_WDIV_RATIO_2 (book=0x00 page=0x01 address=0x67) [reset=20h]
0x68	ASIM_BCLK	AS11 BCLK	ASIM_BCLK (book=0x00 page=0x01 address=0x68) [reset=40h]
0x69	ASIM_WCLK	AS11 WCLK	ASIM_WCLK (book=0x00 page=0x01 address=0x69) [reset=38h]
0x6A	ASIM_DIN	AS11 DIN	ASIM_DIN (book=0x00 page=0x01 address=0x6A) [reset=70h]
0x6C	INT_GEN_1	Interrupt Generation 1	INT_GEN_1 (book=0x00 page=0x01 address=0x6C) [reset=0h]
0x6D	INT_GEN_2	Interrupt Generation 2	INT_GEN_2 (book=0x00 page=0x01 address=0x6D) [reset=0h]
0x6E	INT_GEN_3	Interrupt Generation 3	INT_GEN_3 (book=0x00 page=0x01 address=0x6E) [reset=0h]
0x6F	INT_GEN_4	Interrupt Generation 4	INT_GEN_4 (book=0x00 page=0x01 address=0x6F) [reset=0h]
0x70	INT_GEN_5	Interrupt Generation 5	INT_GEN_5 (book=0x00 page=0x01 address=0x70) [reset=0h]

0x71	INT_GEN_6	Interrupt Generation 6	INT_GEN_6 (book=0x00 page=0x01 address=0x71) [reset=0h]
0x72	INT_IND_MODE	Interrupt Indication Mode	INT_IND_MODE (book=0x00 page=0x01 address=0x72) [reset=0h]
0x73	MAIN_CLK_PIN	Main Clock Source	MAIN_CLK_PIN (book=0x00 page=0x01 address=0x73) [reset=Dh]
0x74	PLL_CLK_PIN	PLL Clock Source	PLL_CLK_PIN (book=0x00 page=0x01 address=0x74) [reset=Dh]
0x75	CLKOUT_MUX	CDIV_CLKIN Clock Source	CLKOUT_MUX (book=0x00 page=0x01 address=0x75) [reset=Dh]
0x76	CLKOUT_CDIV_RATIO	CLKOUT CDIV Ratio	CLKOUT_CDIV_RATIO (book=0x00 page=0x01 address=0x76) [reset=1h]
0x7C	I2C_MISC	I2C Misc	I2C_MISC (book=0x00 page=0x01 address=0x7C) [reset=0h]
0x7D	DEVICE_ID	Device ID	DEVICE_ID (book=0x00 page=0x01 address=0x7D) [reset=12h]

14.1.3 Register Summary Table Book=0x00 Page=0x02

Addr	Register	Description	Section
0x00	PAGE	Page Select	PAGE (book=0x00 page=0x02 address=0x00) [reset=1h]
0x06	RAMP_CTRL	Class-D Ramp Control	RAMP_CTRL (book=0x00 page=0x02 address=0x06) [reset=0h]
0x09	PROTECTION_CFG	Configures the Devices Protection Blocks	PROTECTION_CFG (book=0x00 page=0x02 address=0x09) [reset=3h]

14.2 Register Maps

14.2.1 PAGE (book=0x00 page=0x00 address=0x00) [reset=0h]

Selects the page for the next read or write.

Figure 47. PAGE Register Address: 0x00

7	6	5	4	3	2	1	0
PAGE[7:0]							
RW-0h							

LEGEND: R/W = Read/Write; R = Read only; -n = value after reset

Table 25. Page Select Field Descriptions

Bit	Field	Type	Reset	Description
7-0	PAGE[7:0]	RW	0h	Selects the Register Page for the next read or write command

14.2.2 RESET (book=0x00 page=0x00 address=0x01) [reset=0h]

Controls the software reset

Figure 48. RESET Register Address: 0x01

7	6	5	4	3	2	1	0
Reserved							RESET
R-0h							RW-0h

LEGEND: R/W = Read/Write; R = Read only; -n = value after reset

Table 26. Software Reset Field Descriptions

Bit	Field	Type	Reset	Description
7-1	Reserved	R	0h	Reserved
0	RESET	RW	0h	0 = Don't care 1 = Self clearing software reset

14.2.3 POWER_1 (book=0x00 page=0x00 address=0x04) [reset=0h]

This register controls device power up

Figure 49. POWER_1 Register Address: 0x04

7	6	5	4	3	2	1	0
PWR_DSP	PWR_PLL	PWR_NDIV	PWR_MDAC	PWR_MADC	Reserved	Reserved	PWR_ERR
RW-0h	RW-0h	RW-0h	RW-0h	RW-0h	RW-0h	RW-0h	RW-0h

LEGEND: R/W = Read/Write; R = Read only; -n = value after reset

Table 27. Power Up 1 Field Descriptions

Bit	Field	Type	Reset	Description
7	PWR_DSP	RW	0h	DSP is 0 = Powered-down 1 = Powered-up
6	PWR_PLL	RW	0h	PLL is 0 = Powered-down 1 = Powered-up
5	PWR_NDIV	RW	0h	NDIV is 0 = Powered-down 1 = Powered-up
4	PWR_MDAC	RW	0h	MDAC is 0 = Powered-down 1 = Powered-up
3	PWR_MADC	RW	0h	MADC is 0 = Powered-down 1 = Powered-up
2	Reserved	RW	0h	Reserved
1	Reserved	RW	0h	Reserved
0	PWR_ERR	RW	0h	Reports when a VBAT brownout or clock halt condition was detected. When this is detected several internal blocks are powered down. This register must be cleared first before re-power device. Reason for error is indicated in interrupt register. 0 = No error condition 1 = Error condition detected

14.2.4 POWER_2 (book=0x00 page=0x00 address=0x05) [reset=0h]

This register controls device power up

Figure 50. POWER_2 Register Address: 0x05

7	6	5	4	3	2	1	0
PWR_SPK	Reserved	PWR_BOOST	Reserved			PWR_ISNS	PWR_VSNS
RW-0h	RW-0h	RW-0h	RW-0h			RW-0h	RW-0h

LEGEND: R/W = Read/Write; R = Read only; -n = value after reset

Table 28. Power Up 2 Field Descriptions

Bit	Field	Type	Reset	Description
7	PWR_SPK	RW	0h	Class-D output is 0 = Powered-down 1 = Powered-up
6	Reserved	RW	0h	Reserved
5	PWR_BOOST	RW	0h	Boost is 0 = Powered-down 1 = Powered-up
4-2	Reserved	RW	0h	Reserved
1	PWR_ISNS	RW	0h	Current-sense ADC is 0 = Powered-down 1 = Powered-up

Table 28. Power Up 2 Field Descriptions (continued)

Bit	Field	Type	Reset	Description
0	PWR_VSNS	RW	0h	Voltage-sense ADC is 0 = Powered-down 1 = Powered-up

14.2.5 SPK_GAIN_EDGE (book=0x00 page=0x00 address=0x06) [reset=0h]

This register controls the DAC gain and edge rate control.

Figure 51. SPK_GAIN_EDGE Register Address: 0x06

7	6	5	4	3	2	1	0
Reserved	DAC_GAIN[3:0]			EDGE_RATE[2:0]			
RW-0h	RW-0h			RW-0h			

LEGEND: R/W = Read/Write; R = Read only; -n = value after reset

Table 29. Class-D Speaker Configuration Field Descriptions

Bit	Field	Type	Reset	Description
7	Reserved	RW	0h	Reserved
6-3	DAC_GAIN[3:0]	RW	0h	DAC gain is 0 = 0db 1 = 1db 2 = 2db ... 14 = 14db 15 = 15db
2-0	EDGE_RATE[2:0]	RW	0h	Class-D output edge rate control is 0 = 50ns 1 = 40ns 2 = 29ns 3 = 25ns 4 = 14ns 5 = 13ns 6 = 12ns 7 = 11ns

14.2.6 MUTE (book=0x00 page=0x00 address=0x07) [reset=0h]

This register controls muting of various system blocks.

Figure 52. MUTE Register Address: 0x07

7	6	5	4	3	2	1	0
Reserved	Reserved	Reserved	Reserved		Reserved	MUTE_ISNS	MUTE_VSNS
RW-0h	RW-0h	RW-0h	RW-0h		RW-0h	RW-0h	RW-0h

LEGEND: R/W = Read/Write; R = Read only; -n = value after reset

Table 30. Mute Configuration Field Descriptions

Bit	Field	Type	Reset	Description
7	Reserved	RW	0h	Reserved
6	Reserved	RW	0h	Reserved
5	Reserved	RW	0h	Reserved
4-3	Reserved	RW	0h	Reserved
2	Reserved	RW	0h	Reserved
1	MUTE_ISNS	RW	0h	Current-sense is 0 = Unmuted 1 = Muted

Table 30. Mute Configuration Field Descriptions (continued)

Bit	Field	Type	Reset	Description
0	MUTE_VSNS	RW	0h	Voltage-sense is 0 = Unmuted 1 = Muted

14.2.7 SNS_CTRL (book=0x00 page=0x00 address=0x08) [reset=0h]

This register controls the full scale values of current and voltage sense channels.

Figure 53. SNS_CTRL Register Address: 0x08

7	6	5	4	3	2	1	0
Reserved		Reserved		Reserved	ISNS_SCALE[1:0]		Reserved
RW-0h		RW-0h		RW-0h	RW-0h		RW-0h

LEGEND: R/W = Read/Write; R = Read only; -n = value after reset

Table 31. Sense Channel Control Field Descriptions

Bit	Field	Type	Reset	Description
7-6	Reserved	RW	0h	Reserved
5-4	Reserved	RW	0h	Reserved
3	Reserved	RW	0h	Reserved
2-1	ISNS_SCALE[1:0]	RW	0h	Sets the current and voltage sense input range for various speaker loads. Select the value closest to the nominal load. 0 = 8 ohm load, i-sense full-scale: 1.25A 1 = 6 ohm load, i-sense full-scale: 1.5A 2 = 4 ohm load, i-sense full-scale: 1.75A
0	Reserved	RW	0h	Reserved

14.2.8 BOOST_CTRL_1 (book=0x00 page=0x00 address=0x09) [reset=0h]

This register controls the boost operation.

Figure 54. BOOST_CTRL_1 Register Address: 0x09

7	6	5	4	3	2	1	0
Reserved		Reserved		Reserved		Reserved	BST_MODE
RW-0h		RW-0h		RW-0h		RW-0h	RW-0h

LEGEND: R/W = Read/Write; R = Read only; -n = value after reset

Table 32. Boost Control 1 Field Descriptions

Bit	Field	Type	Reset	Description
7-6	Reserved	RW	0h	Reserved
5-4	Reserved	RW	0h	Reserved
3-2	Reserved	RW	0h	Reserved
1	Reserved	RW	0h	Reserved
0	BST_MODE	RW	0h	Controls the boost operation mode. 0 = Class-H operation using multi-levels. 1 = Class-G operation using one level turned on and off as needed.

14.2.9 SAR_CTRL_2 (book=0x00 page=0x00 address=0x14) [reset=32h]

This register controls the SAR ADC repeat interval, readback register halt, mode, and power state.

Figure 55. SAR_CTRL_2 Register Address: 0x14

7	6	5	4	3	2	1	0
Reserved	SAR_RPT[2:0]			SAR_RBH	SAR_MODE[1:0]		SAR_PWR
RW-0h	RW-3h			RW-0h	RW-1h		RW-0h

LEGEND: R/W = Read/Write; R = Read only; -n = value after reset

Table 33. SAR Control 2 Field Descriptions

Bit	Field	Type	Reset	Description
7	Reserved	RW	0h	Reserved
6-4	SAR_RPT[2:0]	RW	3h	The SAR ADC repeat interval is 0 = 0 us 1 = 50 us 2 = 250 us 3 = 1 ms 4 = 5 ms 5 = 25 ms 6 = 100 ms 7 = 1 s
3	SAR_RBH	RW	0h	Updates to SAR readback registers halt. The readback registers should be halted while read to avoid data corruptions issues from new SAR conversions. 0 = SAR updates readback registers 1 = SAR updates halted
2-1	SAR_MODE[1:0]	RW	1h	Configures the SAR ADC mode of operation 0 = One-shot mode 1 = Repeated scan mode 2 = DSP triggered mode 3 = Reserved
0	SAR_PWR	RW	0h	SAR ADC is 0 = Powered-down 1 = Powered-up

14.2.10 SAR_CTRL_3 (book=0x00 page=0x00 address=0x15) [reset=4h]

This register controls the SAR ADC inputs.

Figure 56. SAR_CTRL_3 Register Address: 0x15

7	6	5	4	3	2	1	0
Reserved				Reserved	SAR_INVBT	SAR_INVBO	SAR_INTMP
RW-0h				RW-0h	RW-1h	RW-0h	RW-0h

LEGEND: R/W = Read/Write; R = Read only; -n = value after reset

Table 34. SAR Control 3 Field Descriptions

Bit	Field	Type	Reset	Description
7-4	Reserved	RW	0h	Reserved
3	Reserved	RW	0h	Reserved
2	SAR_INVBT	RW	1h	SAR VBAT measurement is 0 = disabled 1 = enabled
1	SAR_INVBO	RW	0h	SAR VBOOST measurement is 0 = disabled 1 = enabled
0	SAR_INTMP	RW	0h	SAR temperature measurement is 0 = disabled 1 = enabled

14.2.11 SAR_VBAT_MSB (book=0x00 page=0x00 address=0x16) [reset=0h]

This register contains the VBAT measurement.

Figure 57. SAR_VBAT_MSB Register Address: 0x16

7	6	5	4	3	2	1	0
SR_VBAT[9:2]							
R-0h							

LEGEND: R/W = Read/Write; R = Read only; -n = value after reset

Table 35. SAR VBAT Readback Field Descriptions

Bit	Field	Type	Reset	Description
7--2	SR_VBAT[9:0]	R	0h	VBAT Measured data by SAR ADC[9:2]

14.2.12 SAR_VBAT_LSB (book=0x00 page=0x00 address=0x17) [reset=0h]

This register contains the VBAT measurement.

Figure 58. SAR_VBAT_LSB Register Address: 0x17

7	6	5	4	3	2	1	0
SR_VBAT[1:0]		Reserved					
R-0h		R-0h					

LEGEND: R/W = Read/Write; R = Read only; -n = value after reset

Table 36. SAR VBAT Readback Field Descriptions

Bit	Field	Type	Reset	Description
7-6	SR_VBAT[1:0]	R	0h	VBAT Measured data by SAR ADC[1:0]
5-0	Reserved	R	0h	Reserved

14.2.13 SAR_VBST_MSB (book=0x00 page=0x00 address=0x18) [reset=0h]

This register contains the VBOOST measurement.

Figure 59. SAR_VBST_MSB Register Address: 0x18

7	6	5	4	3	2	1	0
SR_VBST[9:2]							
R-0h							

LEGEND: R/W = Read/Write; R = Read only; -n = value after reset

Table 37. SAR VBOOST Readback Field Descriptions

Bit	Field	Type	Reset	Description
7--2	SR_VBST[9:0]	R	0h	VBOOST Measured data by SAR ADC[9:2]

14.2.14 SAR_VBST_LSB (book=0x00 page=0x00 address=0x19) [reset=0h]

This register contains the VBOOST measurement.

Figure 60. SAR_VBST_LSB Register Address: 0x19

7	6	5	4	3	2	1	0
SR_VBST[1:0]		Reserved					
R-0h		R-0h					

LEGEND: R/W = Read/Write; R = Read only; -n = value after reset

Table 38. SAR VBOOST Readback Field Descriptions

Bit	Field	Type	Reset	Description
7-6	SR_VBST[1:0]	R	0h	VBOOST Measured data by SAR ADC[1:0]
5-0	Reserved	R	0h	Reserved

14.2.15 SAR_TMP1_MSB (book=0x00 page=0x00 address=0x1A) [reset=0h]

This register contains the TEMP1 measurement.

Figure 61. SAR_TMP1_MSB Register Address: 0x1A

7	6	5	4	3	2	1	0
SR_TMP1[9:2]							
R-0h							

LEGEND: R/W = Read/Write; R = Read only; -n = value after reset

Table 39. SAR TEMP1 Readback Field Descriptions

Bit	Field	Type	Reset	Description
7--2	SR_TMP1[9:0]	R	0h	TEMP1 Measured data by SAR ADC[9:2]

14.2.16 SAR_TMP1_LSB (book=0x00 page=0x00 address=0x1B) [reset=0h]

This register contains the TEMP1 measurement.

Figure 62. SAR_TMP1_LSB Register Address: 0x1B

7	6	5	4	3	2	1	0
SR_TMP1[1:0]		Reserved					
R-0h		R-0h					

LEGEND: R/W = Read/Write; R = Read only; -n = value after reset

Table 40. SAR TEMP1 Readback Field Descriptions

Bit	Field	Type	Reset	Description
7-6	SR_TMP1[1:0]	R	0h	TEMP1 Measured data by SAR ADC[1:0]
5-0	Reserved	R	0h	Reserved

14.2.17 SAR_TMP2_MSB (book=0x00 page=0x00 address=0x1C) [reset=0h]

This register contains the TEMP2 measurement.

Figure 63. SAR_TMP2_MSB Register Address: 0x1C

7	6	5	4	3	2	1	0
SR_TMP2[9:2]							
R-0h							

LEGEND: R/W = Read/Write; R = Read only; -n = value after reset

Table 41. SAR TEMP2 Readback Field Descriptions

Bit	Field	Type	Reset	Description
7--2	SR_TMP2[9:0]	R	0h	TEMP2 Measured data by SAR ADC[9:2]

14.2.18 SAR_TMP2_LSB (book=0x00 page=0x00 address=0x1D) [reset=0h]

This register contains the TEMP2 measurement.

Figure 64. SAR_TMP2_LSB Register Address: 0x1D

7	6	5	4	3	2	1	0
SR_TMP2[1:0]		Reserved					
R-0h		R-0h					

LEGEND: R/W = Read/Write; R = Read only; -n = value after reset

Table 42. SAR TEMP2 Readback Field Descriptions

Bit	Field	Type	Reset	Description
7-6	SR_TMP2[1:0]	R	0h	TEMP2 Measured data by SAR ADC[1:0]
5-0	Reserved	R	0h	Reserved

14.2.19 CRC_CHECKSUM (book=0x00 page=0x00 address=0x20) [reset=0h]

Hold the running CRC8 checksum of I2C transactions

Figure 65. CRC_CHECKSUM Register Address: 0x20

7	6	5	4	3	2	1	0
CRC_VAL[7:0]							
R-0h							

LEGEND: R/W = Read/Write; R = Read only; -n = value after reset

Table 43. Checksum Field Descriptions

Bit	Field	Type	Reset	Description
7-0	CRC_VAL[7:0]	R	0h	Current CRC value of all I2C transactions

14.2.20 CRC_RESET (book=0x00 page=0x00 address=0x21) [reset=0h]

This register is used to reset the CRC checksum.

Figure 66. CRC_RESET Register Address: 0x21

7	6	5	4	3	2	1	0
Reserved							CRC_RST
RW-0h							RW-0h

LEGEND: R/W = Read/Write; R = Read only; -n = value after reset

Table 44. Checksum Reset Field Descriptions

Bit	Field	Type	Reset	Description
7-1	Reserved	RW	0h	Reserved
0	CRC_RST	RW	0h	This self clearing bit is used to reset the CRC checksum. This is recommended to be done before PRAM code download. After download the checksum value can be read to confirm download process had any errors or was successful. 0 = normal CRC operation 1 = reset CRC and clear

14.2.21 DSP_CTRL (book=0x00 page=0x00 address=0x22) [reset=1h]

This controls the booting mode of the DSP

Figure 67. DSP_CTRL Register Address: 0x22

7	6	5	4	3	2	1	0
Reserved		Reserved	Reserved	DSP_MODE[3:0]			
RW-0h		RW-0h	RW-0h	RW-1h			

LEGEND: R/W = Read/Write; R = Read only; -n = value after reset

Table 45. DSP Control Field Descriptions

Bit	Field	Type	Reset	Description
7-6	Reserved	RW	0h	Reserved
5	Reserved	RW	0h	Reserved
4	Reserved	RW	0h	Reserved
3-0	DSP_MODE[3:0]	RW	1h	DSP boot in mode 0 = Reserved 1 = PCM input playback only 2 = PCM input playback and IV-sense output 3 = Smart Amp 4 = Smart Amp w/ voice on ASI2 5-15 = Reserved

14.2.22 SSM_CTRL (book=0x00 page=0x00 address=0x28) [reset=0h]

This enables spread-spectrum mode.

Figure 68. SSM_CTRL Register Address: 0x28

7	6	5	4	3	2	1	0
Reserved							SSM_EN
RW-0h							RW-0h

LEGEND: R/W = Read/Write; R = Read only; -n = value after reset

Table 46. Spread-Spectrum Control Field Descriptions

Bit	Field	Type	Reset	Description
7-1	Reserved	RW	0h	Reserved
0	SSM_EN	RW	0h	Enables spread-spectrum mode of the modulator. Ramp clock must be using internal clock not sync mode. This is set in B100_P0_R40 0 = disabled 1 = enabled

14.2.23 ASI_CTRL_1 (book=0x00 page=0x00 address=0x2A) [reset=0h]

This register configures the ASI stereo input modes and soft stepping for mute.

Figure 69. ASI_CTRL_1 Register Address: 0x2A

7	6	5	4	3	2	1	0
Reserved			ASI2_CH[1:0]		ASI1_CH[1:0]		MUTE_SS
RW-0h			RW-0h		RW-0h		RW-0h

LEGEND: R/W = Read/Write; R = Read only; -n = value after reset

Table 47. ASI Control 1 Field Descriptions

Bit	Field	Type	Reset	Description
7-5	Reserved	RW	0h	Reserved
4-3	ASI2_CH[1:0]	RW	0h	Configures the ASI2 input to use 0 = left channel 1 = right channel 2 = (left + right) / 2 3 = monoPCM
2-1	ASI1_CH[1:0]	RW	0h	Configures the ASI1 input to use 0 = left channel 1 = right channel 2 = (left + right) / 2 3 = monoPCM

Table 47. ASI Control 1 Field Descriptions (continued)

Bit	Field	Type	Reset	Description
0	MUTE_SS	RW	0h	When muting and un-muting the channel the audio playback is soft stepped. 0 = enable 1 = disable

14.2.24 BOOST_CTRL_2 (book=0x00 page=0x00 address=0x2B) [reset=3h]

This register controls the boost operation.

Figure 70. BOOST_CTRL_2 Register Address: 0x2B

7	6	5	4	3	2	1	0
Reserved				Reserved	Reserved	BST_ILIM[1:0]	
RW-0h				RW-0h	RW-0h	RW-3h	

LEGEND: R/W = Read/Write; R = Read only; -n = value after reset

Table 48. Boost Control 1 Field Descriptions

Bit	Field	Type	Reset	Description
7-4	Reserved	RW	0h	Reserved
3	Reserved	RW	0h	Reserved
2	Reserved	RW	0h	Reserved
1-0	BST_ILIM[1:0]	RW	3h	Boost current limit 0 = 1.5A 1 = 2.0A 2 = 2.5A 3 = 3.0A

14.2.25 CLOCK_CTRL_1 (book=0x00 page=0x00 address=0x2C) [reset=0h]

Configures the clock error detection handling

Figure 71. CLOCK_CTRL_1 Register Address: 0x2C

7	6	5	4	3	2	1	0
DSP_RSTM	Reserved	CE1_SM	CE1_IC	CE2_IC[1:0]		CE1_EN	CE2_EN
RW-0h	RW-0h	RW-0h	RW-0h	RW-0h		RW-0h	RW-0h

LEGEND: R/W = Read/Write; R = Read only; -n = value after reset

Table 49. Clock Control 1 Field Descriptions

Bit	Field	Type	Reset	Description
7	DSP_RSTM	RW	0h	0 = Reserved
6	Reserved	RW	0h	Reserved
5	CE1_SM	RW	0h	When clock error1 is detected do soft mute using 0 = hardware mute sequence 1 = DSP mute sequence
4	CE1_IC	RW	0h	Clock error detection block 1 input clock is 0 = ASI1 1 = ASI2
3-2	CE2_IC[1:0]	RW	0h	Clock error detection block 2 input clock is 0 = DAC modulator clock 1 = ADC modulator clock 2 = PLL clock 3 = reserved
1	CE1_EN	RW	0h	Clock error detection block 1 is 0 = disabled 1 = enabled

Table 49. Clock Control 1 Field Descriptions (continued)

Bit	Field	Type	Reset	Description
0	CE2_EN	RW	0h	Clock error detection block 2 is 0 = disabled 1 = enabled

14.2.26 CLOCK_CTRL_2 (book=0x00 page=0x00 address=0x2D) [reset=17h]

Configures the clock error detection timeouts

Figure 72. CLOCK_CTRL_2 Register Address: 0x2D

7	6	5	4	3	2	1	0
Reserved	Reserved	Reserved			CE1_STO[2:0]		
RW-0h	RW-0h	RW-2h			RW-7h		

LEGEND: R/W = Read/Write; R = Read only; -n = value after reset

Table 50. Clock Control 2 Field Descriptions

Bit	Field	Type	Reset	Description
7	Reserved	RW	0h	Reserved
6	Reserved	RW	0h	Reserved
5-3	Reserved	RW	2h	Reserved
2-0	CE1_STO[2:0]	RW	7h	Clock error detection block 1 will shutdown the device and set signal PWR_ERR if a clock input does not occur for 0 = 2.73 ms 1 = 22 ms 2 = 44 ms 3 = 87ms 4 = 174 ms 5 = 350 ms 6 = 700 ms 7 = 1.4s

14.2.27 CLOCK_CTRL_3 (book=0x00 page=0x00 address=0x2E) [reset=0h]

Configures the clock error detection timeouts

Figure 73. CLOCK_CTRL_3 Register Address: 0x2E

7	6	5	4	3	2	1	0
CE2_DRR[1:0]		Reserved			CE2_STO[2:0]		
RW-0h		RW-0h			RW-0h		

LEGEND: R/W = Read/Write; R = Read only; -n = value after reset

Table 51. Clock Control 3 Field Descriptions

Bit	Field	Type	Reset	Description
7-6	CE2_DRR[1:0]	RW	0h	For clock error detection block 2 gain ramp-down for DAC channel is 0 = 15 us per dB 1 = 30 us per dB 2 = 60 us per dB 3 = 120 us per dB
5-3	Reserved	RW	0h	Reserved

Table 51. Clock Control 3 Field Descriptions (continued)

Bit	Field	Type	Reset	Description
2-0	CE2_STO[2:0]	RW	0h	Clock error detection block 2 will shutdown the device and set signal PWR_ERR if a clock input does not occur for 0 = 2.73 ms 1 = 22 ms 2 = 44 ms 3 = 87ms 4 = 174 ms 5 = 350 ms 6 = 700 ms 7 = 1.4s

14.2.28 ASI_CTRL_2 (book=0x00 page=0x00 address=0x2F) [reset=0h]

This register sets the PCM sampling rate.

Figure 74. ASI_CTRL_2 Register Address: 0x2F

7	6	5	4	3	2	1	0
Reserved					Reserved	ASI_SR[1:0]	
RW-0h					RW-0h	RW-0h	

LEGEND: R/W = Read/Write; R = Read only; -n = value after reset

Table 52. ASI Control 2 Field Descriptions

Bit	Field	Type	Reset	Description
7-3	Reserved	RW	0h	Reserved
2	Reserved	RW	0h	Reserved
1-0	ASI_SR[1:0]	RW	0h	Sets the sampling rate of the ASI input data in PCM mode to 0 = 8kHz 1 = 16kHz 2 = 48 kHz 3 = 96kHz

14.2.29 CLOCK_CTRL_4 (book=0x00 page=0x00 address=0x32) [reset=0h]

Configures the clock error detection recovery

Figure 75. CLOCK_CTRL_4 Register Address: 0x32

7	6	5	4	3	2	1	0
Reserved						CE2_RM	CE1_RM
RW-0h						RW-0h	RW-0h

LEGEND: R/W = Read/Write; R = Read only; -n = value after reset

Table 53. Clock Control 4 Field Descriptions

Bit	Field	Type	Reset	Description
7-2	Reserved	RW	0h	Reserved
1	CE2_RM	RW	0h	Device automatic recovery when clock error occurs on clock error block 2 0 = enabled 1 = disabled
0	CE1_RM	RW	0h	Device automatic recovery when clock error occurs on clock error block 1 0 = enabled 1 = disabled

14.2.30 DEBUG_1 (book=0x00 page=0x00 address=0x35) [reset=0h]

Debug Register 1

Figure 76. DEBUG_1 Register Address: 0x35

7	6	5	4	3	2	1	0
Reserved					DPU_FRC	TM_I2V	INTG1_EN
RW-0h					RW-0h	RW-0h	RW-0h

LEGEND: R/W = Read/Write; R = Read only; -n = value after reset

Table 54. Debug Register 1 Field Descriptions

Bit	Field	Type	Reset	Description
7-3	Reserved	RW	0h	Reserved
2	DPU_FRC	RW	0h	0 = don't force power down of dummy power up 1 = force power down of dummy power up (use this if dummy power up scheme is going to a hang state)
1	TM_I2V	RW	0h	cont_tm_i2v_startup_en
0	INTG1_EN	RW	0h	enz_intg1_clamping

14.2.31 POWER_STATUS (book=0x00 page=0x00 address=0x64) [reset=0h]

This reports the blocks power state

Figure 77. POWER_STATUS Register Address: 0x64

7	6	5	4	3	2	1	0
PUS_DAC	PUS_SPK	PUS_BST	PUS_BPT	PUS_ISNS	PUS_VSNS	Reserved	
R-0h	R-0h	R-0h	R-0h	R-0h	R-0h	RW-0h	

LEGEND: R/W = Read/Write; R = Read only; -n = value after reset

Table 55. Power Up Status Field Descriptions

Bit	Field	Type	Reset	Description
7	PUS_DAC	R	0h	DAC is 0 = powered down 1 = powered up
6	PUS_SPK	R	0h	Class-D output is 0 = powered down 1 = powered up
5	PUS_BST	R	0h	Boost is 0 = powered down 1 = powered up
4	PUS_BPT	R	0h	Boost pass-thru is 0 = disabled 1 = enabled
3	PUS_ISNS	R	0h	Current-sense ADC is 0 = powered down 1 = powered up
2	PUS_VSNS	R	0h	Voltage-sense ADC is 0 = powered down 1 = powered up
1-0	Reserved	RW	0h	Reserved

14.2.32 DSP_BOOT_STATUS (book=0x00 page=0x00 address=0x65) [reset=0h]

Reports the status of the DSP booting.

Figure 78. DSP_BOOT_STATUS Register Address: 0x65

7	6	5	4	3	2	1	0
Reserved			Reserved		DSP_BS		
R-0h			R-0h		R-0h		

LEGEND: R/W = Read/Write; R = Read only; -n = value after reset

Table 56. DSP Boost Status Field Descriptions

Bit	Field	Type	Reset	Description
7-3	Reserved	R	0h	Reserved
2	DSP_BS	R	0h	The DSP booting is 0 = completed; Host can write coefficient memories 0 = in progress ; Host cannot write coefficient memories
1-0	Reserved	R	0h	Reserved

14.2.33 INT_DET_1 (book=0x00 page=0x00 address=0x68) [reset=0h]

Sticky register used to indicate the source of an interrupt trigger. Register is cleared once read.

Figure 79. INT_DET_1 Register Address: 0x68

7	6	5	4	3	2	1	0
INT_OC	INT_UV	Reserved	INT_OT	INT_BO	INT_CL	INT_SC	Reserved
R-0h	R-0h	R-0h	R-0h	R-0h	R-0h	R-0h	RW-0h

LEGEND: R/W = Read/Write; R = Read only; -n = value after reset

Table 57. Interrupt Detected 1 Field Descriptions

Bit	Field	Type	Reset	Description
7	INT_OC	R	0h	Sticky bit indicating that speaker over current condition 0 = did not occurred since last read 1 = occurred since last read
6	INT_UV	R	0h	Sticky bit indicating that analog under voltage condition 0 = did not occurred since last read 1 = occurred since last read
5	Reserved	R	0h	Reserved
4	INT_OT	R	0h	Sticky bit indicating that die over-temperature condition 0 = did not occurred since last read 1 = occurred since last read
3	INT_BO	R	0h	Sticky bit indicating that brownout condition 0 = did not occurred since last read 1 = occurred since last read
2	INT_CL	R	0h	Sticky bit indicating that the clock is lost condition 0 = did not occurred since last read 1 = occurred since last read
1	INT_SC	R	0h	Sticky bit indicating that the SAR complete condition 0 = did not occurred since last read 1 = occurred since last read
0	Reserved	RW	0h	Reserved

14.2.34 INT_DET_2 (book=0x00 page=0x00 address=0x6C) [reset=0h]

Sticky register used to indicate the source of an interrupt trigger. Register is cleared once read.

Figure 80. INT_DET_2 Register Address: 0x6C

7	6	5	4	3	2	1	0
Reserved	Reserved	Reserved	Reserved	INT_CLK1	INT_CLK2	Reserved	Reserved
R-0h	R-0h	R-0h	R-0h	R-0h	R-0h	R-0h	R-0h

LEGEND: R/W = Read/Write; R = Read only; -n = value after reset

Table 58. Interrupt Detected 2 Field Descriptions

Bit	Field	Type	Reset	Description
7	Reserved	R	0h	Reserved
6	Reserved	R	0h	Reserved
5	Reserved	R	0h	Reserved
4	Reserved	R	0h	Reserved
3	INT_CLK1	R	0h	Sticky bit indicating that clock error 1 condition 0 = did not occurred since last read 1 = occurred since last read
2	INT_CLK2	R	0h	Sticky bit indicating that the clock error 2 condition 0 = did not occurred since last read 1 = occurred since last read
1	Reserved	R	0h	Reserved
0	Reserved	R	0h	Reserved

14.2.35 LOW_POWER (book=0x00 page=0x00 address=0x79) [reset=0h]

Configures the low power shutdown mode.

Figure 81. LOW_POWER Register Address: 0x79

7	6	5	4	3	2	1	0
VBAT_POR	Reserved	Reserved	Reserved	Reserved	Reserved	Reserved	Reserved
RW-0h	RW-0h	RW-0h	RW-0h	RW-0h	RW-0h	RW-0h	RW-0h

LEGEND: R/W = Read/Write; R = Read only; -n = value after reset

Table 59. Lower Power Shutdown Field Descriptions

Bit	Field	Type	Reset	Description
7	VBAT_POR	RW	0h	Disable POR and enter lower power mode. The AVDD and VBATT must be present when this mode is used. Low power is 0 = disabled 1 = enabled
6	Reserved	RW	0h	Reserved
5	Reserved	RW	0h	Reserved
4	Reserved	RW	0h	Reserved
3	Reserved	RW	0h	Reserved
2	Reserved	RW	0h	Reserved
1	Reserved	RW	0h	Reserved
0	Reserved	RW	0h	Reserved

14.2.36 BOOK (book=0x00 page=0x00 address=0x7F) [reset=0h]

Book Selection

Figure 82. BOOK Register Address: 0x7F

7	6	5	4	3	2	1	0
BOOK[7:0]							
RW-0h							

LEGEND: R/W = Read/Write; R = Read only; -n = value after reset

Table 60. Book Selection Field Descriptions

Bit	Field	Type	Reset	Description
7-0	BOOK[7:0]	RW	0h	Set the device book 0 = Book 0 1 = Book 1 ... 255 = Book 255

14.2.37 PAGE (book=0x00 page=0x01 address=0x00) [reset=1h]

Selects the page for the next read or write.

Figure 83. PAGE Register Address: 0x00

7	6	5	4	3	2	1	0
PAGE[7:0]							
RW-1h							

LEGEND: R/W = Read/Write; R = Read only; -n = value after reset

Table 61. Page Select Field Descriptions

Bit	Field	Type	Reset	Description
7-0	PAGE[7:0]	RW	1h	Selects the Register Page for the next read or write command

14.2.38 ASI1_FORMAT (book=0x00 page=0x01 address=0x01) [reset=10h]

Configures the ASI1 format, wordlength, and tristate.

Figure 84. ASI1_FORMAT Register Address: 0x01

7	6	5	4	3	2	1	0
ASI1_MODE[2:0]			ASI1_LENGTH[1:0]		Reserved		ASI1_TRISTATE
RW-0h			RW-2h		RW-0h		RW-0h

LEGEND: R/W = Read/Write; R = Read only; -n = value after reset

Table 62. ASI1 Format Field Descriptions

Bit	Field	Type	Reset	Description
7-5	ASI1_MODE[2:0]	RW	0h	The ASI1 Input mode format is set to 0 = I2S 1 = DSP 2 = RJF , For non-zero values of ASI1_OFFSET1, LJF is preferred 3 = LJF 4 = MonoPCM 5-15 = Reserved
4-3	ASI1_LENGTH[1:0]	RW	2h	Sets the ASI1 input word-length to 0 = 16bits 1 = 20bits 2 = 24bits 3 = 32bits
2-1	Reserved	RW	0h	Reserved
0	ASI1_TRISTATE	RW	0h	Tri-stating of DOUT for the extra ASI1_BCLK cycles after Data Transfer is over for a frame is 0 = Disabled 1 = Enabled

14.2.39 ASI1_OFFSET_1 (book=0x00 page=0x01 address=0x03) [reset=0h]

Configures the ASI input offset. Offset is measured with respect to WCLK-rising edge in DSP Mode. Offset is not supported for RJF mode

Figure 85. ASI1_OFFSET_1 Register Address: 0x03

7	6	5	4	3	2	1	0
ASI1_OFFSET1[7:0]							
RW-0h							

LEGEND: R/W = Read/Write; R = Read only; -n = value after reset

Table 63. ASI1 Offset Field Descriptions

Bit	Field	Type	Reset	Description
7-0	ASI1_OFFSET1[7:0]	RW	0h	ASI1_OFFSET1[7:0]

14.2.40 ASI1_BUSKEEP (book=0x00 page=0x01 address=0x05) [reset=0h]

Configures the buskeeper operation.

Figure 86. ASI1_BUSKEEP Register Address: 0x05

7	6	5	4	3	2	1	0
ASI1_BKP	Reserved						0
RW-0h	RW-0h						RW-0h

LEGEND: R/W = Read/Write; R = Read only; -n = value after reset

Table 64. ASI1 Buskeeper Field Descriptions

Bit	Field	Type	Reset	Description
7	ASI1_BKP	RW	0h	Bus keep power down when DOUT is tri-stated to save IO power is 0 = disabled 1 = enabled
6-0	Reserved	RW	0h	Reserved

14.2.41 ASI1_BCLK (book=0x00 page=0x01 address=0x08) [reset=0h]

Configures the bit clock pin, timing, and free running mode

Figure 87. ASI1_BCLK Register Address: 0x08

7	6	5	4	3	2	1	0
Reserved	ASI1_BCLK[3:0]				Reserved	ASI1_BCT	ASI1_FRM
RW-0h	RW-0h				RW-0h	RW-0h	RW-0h

LEGEND: R/W = Read/Write; R = Read only; -n = value after reset

Table 65. ASI1 BCLK Field Descriptions

Bit	Field	Type	Reset	Description
7	Reserved	RW	0h	Reserved
6-3	ASI1_BCLK[3:0]	RW	0h	ASI1 BCLK input is from 0 = GPIO1 (Preferred pin usage) 1 = GPIO2 2 = GPIO3 3 = GPIO4 4 = GPIO5 5 = GPIO6 6 = GPIO7 7 = GPIO8 8 = GPIO9 9 = GPIO10 10-11 = Reserved 12 = GPI1 13 = GPI2 14 = GPI3 15-31 = Reserved
2	Reserved	RW	0h	Reserved
1	ASI1_BCT	RW	0h	ASI1 BCLK timing as per timing protocol is 0 = normal 1 = inverted
0	ASI1_FRM	RW	0h	ASI1 BCLK and WCLK are 0 = active in output modes only when ASI1 is active and codec is powered up 1 = is free-running

14.2.42 ASI1_WCLK (book=0x00 page=0x01 address=0x09) [reset=8h]

Configures the word clock pin and timing

Figure 88. ASI1_WCLK Register Address: 0x09

7	6	5	4	3	2	1	0
Reserved	ASI1_WCLK[3:0]				Reserved	ASI1_WCT	Reserved
RW-0h	RW-1h				RW-0h	RW-0h	RW-0h

LEGEND: R/W = Read/Write; R = Read only; -n = value after reset

Table 66. ASI1 WCLK Field Descriptions

Bit	Field	Type	Reset	Description
7	Reserved	RW	0h	Reserved
6-3	ASI1_WCLK[3:0]	RW	1h	ASI1 WCLK input is from 0 = GPIO1 1 = GPIO2 (Preferred pin usage) 2 = GPIO3 3 = GPIO4 4 = GPIO5 5 = GPIO6 6 = GPIO7 7 = GPIO8 8 = GPIO9 9 = GPIO10 10-11 = Reserved 12 = GPI1 13 = GPI2 14 = GPI3 15-31 = Reserved
2	Reserved	RW	0h	Reserved
1	ASI1_WCT	RW	0h	ASI1 WCLK timing as per timing protocol is 0 = normal 1 = inverted

Table 66. ASI1 WCLK Field Descriptions (continued)

Bit	Field	Type	Reset	Description
0	Reserved	RW	0h	Reserved

14.2.43 ASI1_DIN_DOUT (book=0x00 page=0x01 address=0x0C) [reset=0h]

Configures the digital input and output ports.

Figure 89. ASI1_DIN_DOUT Register Address: 0x0C

7	6	5	4	3	2	1	0
Reserved	ASI1_DIN[3:0]				Reserved	ASI1_DOUT[1:0]	
RW-0h	RW-0h				RW-0h	RW-0h	

LEGEND: R/W = Read/Write; R = Read only; -n = value after reset

Table 67. ASI1 DIN/DOUT Field Descriptions

Bit	Field	Type	Reset	Description
7	Reserved	RW	0h	Reserved
6-3	ASI1_DIN[3:0]	RW	0h	ASI1 DIN input is from 0 = GPIO1 1 = GPIO2 2 = GPIO3 3 = GPIO4 4 = GPIO5 5 = GPIO6 6 = GPIO7 7 = GPIO8 8 = GPIO9 9 = GPIO10 10-11 = Reserved 12 = GPI1 (Preferred pin usage) 13 = GPI2 14 = GPI3 15-31 = Reserved
2	Reserved	RW	0h	Reserved
1-0	ASI1_DOUT[1:0]	RW	0h	ASI1 DOUT output is 0 = DOUT path, output buffer enabled only if i-sense is powered up 1 = ASI1_DIN, loopback 2 = ASI2_DIN, loopback 3 = DOUT path, output buffer enable controlled only based on ASI1 configuration

14.2.44 ASI1_BDIV_CLK (book=0x00 page=0x01 address=0x0D) [reset=1h]

Selects the BDIV clock source

Figure 90. ASI1_BDIV_CLK Register Address: 0x0D

7	6	5	4	3	2	1	0
Reserved					ASI1_BDIV_SRC[2:0]		
RW-0h					RW-1h		

LEGEND: R/W = Read/Write; R = Read only; -n = value after reset

Table 68. ASI1 BDIV Clock Field Descriptions

Bit	Field	Type	Reset	Description
7-3	Reserved	RW	0h	Reserved
2-0	ASI1_BDIV_SRC[2:0]	RW	1h	ASI1 bit clock divider (BDIV) source is 0 = NDIV_CLK (Generated On-Chip) 1 = DAC_MOD_CLK (Generated On-Chip) 2 = Reserved 3 = ADC_MOD_CLK (Generated On-Chip) 4 = ASI1_DAC_BCLK (at pin) 5 = Reserved 6 = ASI2_DAC_BCLK (at pin) 7 = Reserved

14.2.45 ASI1_BDIV_RATIO (book=0x00 page=0x01 address=0x0E) [reset=2h]

Configure the BDIV ratio and power.

Figure 91. ASI1_BDIV_RATIO Register Address: 0x0E

7	6	5	4	3	2	1	0
ASI1_BDIV_P WR	ASI1_BDIV_RTO[6:0]						
RW-0h	RW-2h						

LEGEND: R/W = Read/Write; R = Read only; -n = value after reset

Table 69. ASI1 BDIV Ratio Field Descriptions

Bit	Field	Type	Reset	Description
7	ASI1_BDIV_PWR	RW	0h	The ASI1 BDIV divider is 0 = powered down 1 = powered up
6-0	ASI1_BDIV_RTO[6:0]	RW	2h	The ASI1 BDIV ratio is 0 = 128 1 = 1 2 = 2 ... 126 = 126 127 = 127

14.2.46 ASI1_WDIV_RATIO (book=0x00 page=0x01 address=0x0F) [reset=20h]

Configure the WDIV ratio and power.

Figure 92. ASI1_WDIV_RATIO Register Address: 0x0F

7	6	5	4	3	2	1	0
ASI1_WDIV_P WR	ASI1_WDIV_RTO[6:0]						
RW-0h	RW-20h						

LEGEND: R/W = Read/Write; R = Read only; -n = value after reset

Table 70. ASI1 WDIV Ratio Field Descriptions

Bit	Field	Type	Reset	Description
7	ASI1_WDIV_PWR	RW	0h	The ASI1 WDIV divider is 0 = powered down 1 = powered up

Table 70. ASI1 WDIV Ratio Field Descriptions (continued)

Bit	Field	Type	Reset	Description
6-0	ASI1_WDIV_RATIO[6:0]	RW	20h	The ASI1 WDIV ratio is 0 = 128 1 = 1 2 = 2 ... 126 = 126 127 = 127

14.2.47 ASI1_CLK_OUT (book=0x00 page=0x01 address=0x10) [reset=0h]

Configures the clock source for BCLK and WCLK

Figure 93. ASI1_CLK_OUT Register Address: 0x10

7	6	5	4	3	2	1	0
Reserved	ASI1_BCLKS[2:0]			Reserved	ASI1_WCLKS[2:0]		
RW-0h	RW-0h			RW-0h	RW-0h		

LEGEND: R/W = Read/Write; R = Read only; -n = value after reset

Table 71. ASI1 Clock Source Field Descriptions

Bit	Field	Type	Reset	Description
7	Reserved	RW	0h	Reserved
6-4	ASI1_BCLKS[2:0]	RW	0h	ASI1 bit clock(BCLK) output source is 0 = ASI1 BDIV divider output 1 = ASI1 DAC clock 2 = Reserved 3 = ASI2 BDIV divider output 4 = ASI2 DAC clock 5=15 = Reserved
3	Reserved	RW	0h	Reserved
2-0	ASI1_WCLKS[2:0]	RW	0h	ASI1 bit clock(WCLK) output source is 0 = ASI1 WDIV divider output 1 = ASI1 DAC clock 2 = Reserved 3 = ASI2 WDIV divider output 4 = ASI2 DAC clock 5=15 = Reserved

14.2.48 ASI2_FORMAT (book=0x00 page=0x01 address=0x15) [reset=10h]

Configures the ASI2 format, wordlength, and tristate.

Figure 94. ASI2_FORMAT Register Address: 0x15

7	6	5	4	3	2	1	0
ASI2_MODE[2:0]			ASI2_LENGTH[1:0]		Reserved		ASI2_TRISTATE
RW-0h			RW-2h		RW-0h		RW-0h

LEGEND: R/W = Read/Write; R = Read only; -n = value after reset

Table 72. ASI2 Format Field Descriptions

Bit	Field	Type	Reset	Description
7-5	ASI2_MODE[2:0]	RW	0h	The ASI1 Input mode format is set to 0 = I2S 1 = DSP 2 = RJF , For non-zero values of ASI2_OFFSET1, LJF is preferred 3 = LJF 4 = MonoPCM 5-15 = Reserved

Table 72. ASI2 Format Field Descriptions (continued)

Bit	Field	Type	Reset	Description
4-3	ASI2_LENGTH[1:0]	RW	2h	Sets the ASI2 input word-length to 0 = 16bits 1 = 20bits 2 = 24bits 3 = 32bits
2-1	Reserved	RW	0h	Reserved
0	ASI2_TRISTATE	RW	0h	Tri-stating of DOUT for the extra ASI2_BCLK cycles after Data Transfer is over for a frame is 0 = Disabled 1 = Enabled

14.2.49 ASI2_OFFSET_1 (book=0x00 page=0x01 address=0x17) [reset=0h]

Configures the ASI input offset. Offset is measured with respect to WCLK-rising edge in DSP Mode. Offset is not supported for RJF mode

Figure 95. ASI2_OFFSET_1 Register Address: 0x17

7	6	5	4	3	2	1	0
ASI2_OFFSET1[7:0]							
RW-0h							

LEGEND: R/W = Read/Write; R = Read only; -n = value after reset

Table 73. ASI2 Offset Field Descriptions

Bit	Field	Type	Reset	Description
7-0	ASI2_OFFSET1[7:0]	RW	0h	ASI2_OFFSET1[7:0]

14.2.50 ASI2_BUSKEEP (book=0x00 page=0x01 address=0x19) [reset=0h]

Configures the buskeeper operation.

Figure 96. ASI2_BUSKEEP Register Address: 0x19

7	6	5	4	3	2	1	0
ASI2_BKP	Reserved						
RW-0h	RW-0h						

LEGEND: R/W = Read/Write; R = Read only; -n = value after reset

Table 74. ASI2 Buskeeper Field Descriptions

Bit	Field	Type	Reset	Description
7	ASI2_BKP	RW	0h	Bus keep power down when DOUT is tri-stated to save IO power is 0 = disabled 1 = enabled
6-0	Reserved	RW	0h	Reserved

14.2.51 ASI2_BCLK (book=0x00 page=0x01 address=0x1C) [reset=20h]

Configures the bit clock pin, timing, and free running mode

Figure 97. ASI2_BCLK Register Address: 0x1C

7	6	5	4	3	2	1	0
Reserved	ASI2_BCLK[3:0]				Reserved	ASI2_BCT	ASI2_FRM
RW-0h	RW-4h				RW-0h	RW-0h	RW-0h

LEGEND: R/W = Read/Write; R = Read only; -n = value after reset

Table 75. ASI2 BCLK Field Descriptions

Bit	Field	Type	Reset	Description
7	Reserved	RW	0h	Reserved
6-3	ASI2_BCLK[3:0]	RW	4h	ASI2 BCLK input is from 0 = GPIO1 1 = GPIO2 2 = GPIO3 3 = GPIO4 4 = GPIO5 (Preferred pin usage) 5 = GPIO6 6 = GPIO7 7 = GPIO8 8 = GPIO9 9 = GPIO10 10-11 = Reserved 12 = GPI1 13 = GPI2 14 = GPI3 15-31 = Reserved
2	Reserved	RW	0h	Reserved
1	ASI2_BCT	RW	0h	ASI2 BCLK timing as per timing protocol is 0 = normal 1 = inverted
0	ASI2_FRM	RW	0h	ASI2 BCLK and WCLK are 0 = active in output modes only when ASI2 is active and codec is powered up 1 = is free-running

14.2.52 ASI2_WCLK (book=0x00 page=0x01 address=0x1D) [reset=28h]

Configures the word clock pin and timing

Figure 98. ASI2_WCLK Register Address: 0x1D

7	6	5	4	3	2	1	0
Reserved	ASI2_WCLK[3:0]				Reserved	ASI2_WCT	Reserved
RW-0h	RW-5h				RW-0h	RW-0h	RW-0h

LEGEND: R/W = Read/Write; R = Read only; -n = value after reset

Table 76. ASI2 WCLK Field Descriptions

Bit	Field	Type	Reset	Description
7	Reserved	RW	0h	Reserved
6-3	ASI2_WCLK[3:0]	RW	5h	ASI2 WCLK input is from 0 = GPIO1 1 = GPIO2 2 = GPIO3 3 = GPIO4 4 = GPIO5 5 = GPIO6 (Preferred pin usage) 6 = GPIO7 7 = GPIO8 8 = GPIO9 9 = GPIO10 10-11 = Reserved 12 = GPI1 13 = GPI2 14 = GPI3 15-31 = Reserved
2	Reserved	RW	0h	Reserved
1	ASI2_WCT	RW	0h	ASI2 WCLK timing as per timing protocol is 0 = normal 1 = inverted
0	Reserved	RW	0h	Reserved

14.2.53 ASI2_DIN_DOUT (book=0x00 page=0x01 address=0x20) [reset=38h]

Configures the digital input and output ports.

Figure 99. ASI2_DIN_DOUT Register Address: 0x20

7	6	5	4	3	2	1	0
Reserved	ASI2_DIN[3:0]				Reserved	ASI2_DOUT[1:0]	
RW-0h	RW-7h				RW-0h	RW-0h	

LEGEND: R/W = Read/Write; R = Read only; -n = value after reset

Table 77. ASI2 DIN/DOUT Field Descriptions

Bit	Field	Type	Reset	Description
7	Reserved	RW	0h	Reserved
6-3	ASI2_DIN[3:0]	RW	7h	ASI2 DIN input is from 0 = GPIO1 1 = GPIO2 2 = GPIO3 3 = GPIO4 4 = GPIO5 5 = GPIO6 6 = GPIO7 7 = GPIO8 (Preferred pin usage) 8 = GPIO9 9 = GPIO10 10-11 = Reserved 12 = GPI1 13 = GPI2 14 = GPI3 15-31 = Reserved
2	Reserved	RW	0h	Reserved
1-0	ASI2_DOUT[1:0]	RW	0h	ASI2 DOUT output is 0 = DOUT path, output buffer enabled only if i-sense is powered up 1 = ASI1_DIN, loopback 2 = ASI2_DIN, loopback 3 = DOUT path, output buffer enable controlled only based on ASI1 configuration

14.2.54 ASI2_BDIV_CLK (book=0x00 page=0x01 address=0x21) [reset=1h]

Selects the BDIV clock source

Figure 100. ASI2_BDIV_CLK Register Address: 0x21

7	6	5	4	3	2	1	0
Reserved					ASI2_BDIV_SRC[2:0]		
RW-0h					RW-1h		

LEGEND: R/W = Read/Write; R = Read only; -n = value after reset

Table 78. ASI2 BDIV Clock Field Descriptions

Bit	Field	Type	Reset	Description
7-3	Reserved	RW	0h	Reserved
2-0	ASI2_BDIV_SRC[2:0]	RW	1h	ASI1 bit clock divider (BDIV) source is 0 = NDIV_CLK (Generated On-Chip) 1 = DAC_MOD_CLK (Generated On-Chip) 2 = Reserved 3 = ADC_MOD_CLK (Generated On-Chip) 4 = ASI1_DAC_BCLK (at pin) 5 = Reserved 6 = ASI2_DAC_BCLK (at pin) 7 = Reserved

14.2.55 ASI2_BDIV_RATIO (book=0x00 page=0x01 address=0x22) [reset=2h]

Configure the BDIV ratio and power.

Figure 101. ASI2_BDIV_RATIO Register Address: 0x22

7	6	5	4	3	2	1	0
ASI2_BDIV_P WR	ASI2_BDIV_RTO[6:0]						
RW-0h	RW-2h						

LEGEND: R/W = Read/Write; R = Read only; -n = value after reset

Table 79. ASI2 BDIV Ratio Field Descriptions

Bit	Field	Type	Reset	Description
7	ASI2_BDIV_PWR	RW	0h	The ASI2 BDIV divider is 0 = powered down 1 = powered up
6-0	ASI2_BDIV_RTO[6:0]	RW	2h	The ASI2 BDIV ratio is 0 = 128 1 = 1 2 = 2 ... 126 = 126 127 = 127

14.2.56 ASI2_WDIV_RATIO (book=0x00 page=0x01 address=0x23) [reset=20h]

Configure the WDIV ratio and power.

Figure 102. ASI2_WDIV_RATIO Register Address: 0x23

7	6	5	4	3	2	1	0
ASI2_WDIV_P WR	ASI2_WDIV_RTO[6:0]						
RW-0h	RW-20h						

LEGEND: R/W = Read/Write; R = Read only; -n = value after reset

Table 80. ASI2 WDIV Ratio Field Descriptions

Bit	Field	Type	Reset	Description
7	ASI2_WDIV_PWR	RW	0h	The ASI2 WDIV divider is 0 = powered down 1 = powered up
6-0	ASI2_WDIV_RTO[6:0]	RW	20h	The ASI2 WDIV ratio is 0 = 128 1 = 1 2 = 2 ... 126 = 126 127 = 127

14.2.57 ASI2_CLK_OUT (book=0x00 page=0x01 address=0x24) [reset=33h]

Configures the clock source for BCLK and WCLK

Figure 103. ASI2_CLK_OUT Register Address: 0x24

7	6	5	4	3	2	1	0
Reserved	ASI2_BCLKS[2:0]			Reserved	ASI2_WCLKS[2:0]		
RW-0h	RW-3h			RW-0h	RW-3h		

LEGEND: R/W = Read/Write; R = Read only; -n = value after reset

Table 81. ASI2 Clock Source Field Descriptions

Bit	Field	Type	Reset	Description
7	Reserved	RW	0h	Reserved
6-4	ASI2_BCLKS[2:0]	RW	3h	ASI2 bit clock(BCLK) output source is 0 = ASI1 BDIV divider output 1 = ASI1 DAC clock 2 = Reserved 3 = ASI2 BDIV divider output 4 = ASI2 DAC clock 5=15 = Reserved
3	Reserved	RW	0h	Reserved
2-0	ASI2_WCLKS[2:0]	RW	3h	ASI2 bit clock(WCLK) output source is 0 = ASI1 WDIV divider output 1 = ASI1 DAC clock 2 = Reserved 3 = ASI2 WDIV divider output 4 = ASI2 DAC clock 5=15 = Reserved

14.2.58 GPIO1_PIN (book=0x00 page=0x01 address=0x3D) [reset=1h]

Configures BCLK1_GPIO1 pin.

Figure 104. GPIO1_PIN Register Address: 0x3D

7	6	5	4	3	2	1	0	
Reserved	GP1_VAL	Reserved	GP1_OUT[4:0]					
RW-0h	RW-0h	RW-0h	RW-1h					

LEGEND: R/W = Read/Write; R = Read only; -n = value after reset

Table 82. GPIO1 Field Descriptions

Bit	Field	Type	Reset	Description
7	Reserved	RW	0h	Reserved
6	GP1_VAL	RW	0h	When value GP1_OUT=3, configure pin output to 0 = Low 1 = High
5	Reserved	RW	0h	Reserved
4-0	GP1_OUT[4:0]	RW	1h	Pin is configured to 0 = disabled, buffers powered down 1 = input, use input MUX for relevant function 2 = Reserved 3 = output, use GP1_VAL to set value 4 = output, use GPBB_VAL to set value 5 = output, PDM clk output for PDM data input 6 = output, CLKOUT output 7 = output, INT1 interrupt 8 = output, INT2 interrupt 9 = output, INT3 interrupt 10 = output, INT4 interrupt 11 = Reserved 12 = output, ASI1_WCLK_OUT 13 = output, ASI1_BCLK_OUT 14-15 = Reserved 16 = ASI1_DOUT 17 = ASI1_WCLK_OUT 18 = ASI2_BCLK_OUT 19-20 = Reserved 21 = ASI2_DOUT 22-26 = Reserved 27 = ASIM_WCLK_OUT 28 = ASIM_BCLK_OUT 29 = ASIM_DOUT 30-31 = Reserved

14.2.59 GPIO2_PIN (book=0x00 page=0x01 address=0x3E) [reset=1h]

Configures WCLK1_GPIO2 pin.

Figure 105. GPIO2_PIN Register Address: 0x3E

7	6	5	4	3	2	1	0
Reserved	GP2_VAL	Reserved	GP2_OUT[4:0]				
RW-0h	RW-0h	RW-0h	RW-1h				

LEGEND: R/W = Read/Write; R = Read only; -n = value after reset

Table 83. GPIO2 Field Descriptions

Bit	Field	Type	Reset	Description
7	Reserved	RW	0h	Reserved
6	GP2_VAL	RW	0h	When value GP2_OUT=3, configure pin output to 0 = Low 1 = High
5	Reserved	RW	0h	Reserved
4-0	GP2_OUT[4:0]	RW	1h	Pin is configured to 0 = disabled, buffers powered down 1 = input, use input MUX for relevant function 2 = Reserved 3 = output, use GP2_VAL to set value 4 = output, use GPBB_VAL to set value 5 = output, PDM clk output for PDM data input 6 = output, CLKOUT output 7 = output, INT1 interrupt 8 = output, INT2 interrupt 9 = output, INT3 interrupt 10 = output, INT4 interrupt 11 = Reserved 12 = output, ASI1_WCLK_OUT 13 = output, ASI1_BCLK_OUT 14-15 = Reserved 16 = ASI1_DOUT 17 = ASI1_WCLK_OUT 18 = ASI2_BCLK_OUT 19-20 = Reserved 21 = ASI2_DOUT 22-26 = Reserved 27 = ASIM_WCLK_OUT 28 = ASIM_BCLK_OUT 29 = ASIM_DOUT 30-31 = Reserved

14.2.60 GPIO3_PIN (book=0x00 page=0x01 address=0x3F) [reset=10h]

Configures DOUT1_GPIO3 pin.

Figure 106. GPIO3_PIN Register Address: 0x3F

7	6	5	4	3	2	1	0
Reserved	GP3_VAL	Reserved	GP3_OUT[4:0]				
RW-0h	RW-0h	RW-0h	RW-10h				

LEGEND: R/W = Read/Write; R = Read only; -n = value after reset

Table 84. GPIO3 Field Descriptions

Bit	Field	Type	Reset	Description
7	Reserved	RW	0h	Reserved
6	GP3_VAL	RW	0h	When value GP3_OUT=3, configure pin output to 0 = Low 1 = High
5	Reserved	RW	0h	Reserved

Table 84. GPIO3 Field Descriptions (continued)

Bit	Field	Type	Reset	Description
4-0	GP3_OUT[4:0]	RW	10h	Pin is configured to 0 = disabled, buffers powered down 1 = input, use input MUX for relevant function 2 = Reserved 3 = output, use GP3_VAL to set value 4 = output, use GPBB_VAL to set value 5 = output, PDM clk output for PDM data input 6 = output, CLKOUT output 7 = output, INT1 interrupt 8 = output, INT2 interrupt 9 = output, INT3 interrupt 10 = output, INT4 interrupt 11 = Reserved 12 = output, ASI1_WCLK_OUT 13 = output, ASI1_BCLK_OUT 14-15 = Reserved 16 = ASI1_DOUT 17 = ASI1_WCLK_OUT 18 = ASI2_BCLK_OUT 19-20 = Reserved 21 = ASI2_DOUT 22-26 = Reserved 27 = ASIM_WCLK_OUT 28 = ASIM_BCLK_OUT 29 = ASIM_DOUT 30-31 = Reserved

14.2.61 GPIO4_PIN (book=0x00 page=0x01 address=0x40) [reset=7h]

Configures IRQ_GPIO4 pin.

Figure 107. GPIO4_PIN Register Address: 0x40

7	6	5	4	3	2	1	0
Reserved	GP4_VAL	Reserved	GP4_OUT[4:0]				
RW-0h	RW-0h	RW-0h	RW-7h				

LEGEND: R/W = Read/Write; R = Read only; -n = value after reset

Table 85. GPIO4 Field Descriptions

Bit	Field	Type	Reset	Description
7	Reserved	RW	0h	Reserved
6	GP4_VAL	RW	0h	When value GP4_OUT=3, configure pin output to 0 = Low 1 = High
5	Reserved	RW	0h	Reserved

Table 85. GPIO4 Field Descriptions (continued)

Bit	Field	Type	Reset	Description
4-0	GP4_OUT[4:0]	RW	7h	Pin is configured to 0 = disabled, buffers powered down 1 = input, use input MUX for relevant function 2 = Reserved 3 = output, use GP4_VAL to set value 4 = output, use GPBB_VAL to set value 5 = output, PDM clk output for PDM data input 6 = output, CLKOUT output 7 = output, INT1 interrupt 8 = output, INT2 interrupt 9 = output, INT3 interrupt 10 = output, INT4 interrupt 11 = Reserved 12 = output, ASI1_WCLK_OUT 13 = output, ASI1_BCLK_OUT 14-15 = Reserved 16 = ASI1_DOUT 17 = ASI1_WCLK_OUT 18 = ASI2_BCLK_OUT 19-20 = Reserved 21 = ASI2_DOUT 22-26 = Reserved 27 = ASIM_WCLK_OUT 28 = ASIM_BCLK_OUT 29 = ASIM_DOUT 30-31 = Reserved

14.2.62 GPIO5_PIN (book=0x00 page=0x01 address=0x41) [reset=0h]

Configures BCLK2_GPIO5 pin.

Figure 108. GPIO5_PIN Register Address: 0x41

7	6	5	4	3	2	1	0	
Reserved	GP5_VAL	Reserved	GP5_OUT[4:0]					
RW-0h	RW-0h	RW-0h	RW-0h					

LEGEND: R/W = Read/Write; R = Read only; -n = value after reset

Table 86. GPIO5 Field Descriptions

Bit	Field	Type	Reset	Description
7	Reserved	RW	0h	Reserved
6	GP5_VAL	RW	0h	When value GP5_OUT=3, configure pin output to 0 = Low 1 = High
5	Reserved	RW	0h	Reserved

Table 86. GPIO5 Field Descriptions (continued)

Bit	Field	Type	Reset	Description
4-0	GP5_OUT[4:0]	RW	0h	Pin is configured to 0 = disabled, buffers powered down 1 = input, use input MUX for relevant function 2 = Reserved 3 = output, use GP5_VAL to set value 4 = output, use GPBB_VAL to set value 5 = output, PDM clk output for PDM data input 6 = output, CLKOUT output 7 = output, INT1 interrupt 8 = output, INT2 interrupt 9 = output, INT3 interrupt 10 = output, INT4 interrupt 11 = Reserved 12 = output, ASI1_WCLK_OUT 13 = output, ASI1_BCLK_OUT 14-15 = Reserved 16 = ASI1_DOUT 17 = ASI1_WCLK_OUT 18 = ASI2_BCLK_OUT 19-20 = Reserved 21 = ASI2_DOUT 22-26 = Reserved 27 = ASIM_WCLK_OUT 28 = ASIM_BCLK_OUT 29 = ASIM_DOUT 30-31 = Reserved

14.2.63 GPIO6_PIN (book=0x00 page=0x01 address=0x42) [reset=0h]

Configures WCLK2_GPIO6 pin.

Figure 109. GPIO6_PIN Register Address: 0x42

7	6	5	4	3	2	1	0
Reserved	GP6_VAL	Reserved	GP6_OUT[4:0]				
RW-0h	RW-0h	RW-0h	RW-0h				

LEGEND: R/W = Read/Write; R = Read only; -n = value after reset

Table 87. GPIO6 Field Descriptions

Bit	Field	Type	Reset	Description
7	Reserved	RW	0h	Reserved
6	GP6_VAL	RW	0h	When value GP6_OUT=3, configure pin output to 0 = Low 1 = High
5	Reserved	RW	0h	Reserved

Table 87. GPIO6 Field Descriptions (continued)

Bit	Field	Type	Reset	Description
4-0	GP6_OUT[4:0]	RW	0h	Pin is configured to 0 = disabled, buffers powered down 1 = input, use input MUX for relevant function 2 = Reserved 3 = output, use GP6_VAL to set value 4 = output, use GPBB_VAL to set value 5 = output, PDM clk output for PDM data input 6 = output, CLKOUT output 7 = output, INT1 interrupt 8 = output, INT2 interrupt 9 = output, INT3 interrupt 10 = output, INT4 interrupt 11 = Reserved 12 = output, ASI1_WCLK_OUT 13 = output, ASI1_BCLK_OUT 14-15 = Reserved 16 = ASI1_DOUT 17 = ASI1_WCLK_OUT 18 = ASI2_BCLK_OUT 19-20 = Reserved 21 = ASI2_DOUT 22-26 = Reserved 27 = ASIM_WCLK_OUT 28 = ASIM_BCLK_OUT 29 = ASIM_DOUT 30-31 = Reserved

14.2.64 GPIO7_PIN (book=0x00 page=0x01 address=0x43) [reset=0h]

Configures DOUT2_GPIO7 pin.

Figure 110. GPIO7_PIN Register Address: 0x43

7	6	5	4	3	2	1	0	
Reserved	GP7_VAL	Reserved	GP7_OUT[4:0]					
RW-0h	RW-0h	RW-0h	RW-0h					

LEGEND: R/W = Read/Write; R = Read only; -n = value after reset

Table 88. GPIO7 Field Descriptions

Bit	Field	Type	Reset	Description
7	Reserved	RW	0h	Reserved
6	GP7_VAL	RW	0h	When value GP7_OUT=3, configure pin output to 0 = Low 1 = High
5	Reserved	RW	0h	Reserved

Table 88. GPIO7 Field Descriptions (continued)

Bit	Field	Type	Reset	Description
4-0	GP7_OUT[4:0]	RW	0h	Pin is configured to 0 = disabled, buffers powered down 1 = input, use input MUX for relevant function 2 = Reserved 3 = output, use GP7_VAL to set value 4 = output, use GPBB_VAL to set value 5 = output, PDM clk output for PDM data input 6 = output, CLKOUT output 7 = output, INT1 interrupt 8 = output, INT2 interrupt 9 = output, INT3 interrupt 10 = output, INT4 interrupt 11 = Reserved 12 = output, ASI1_WCLK_OUT 13 = output, ASI1_BCLK_OUT 14-15 = Reserved 16 = ASI1_DOUT 17 = ASI1_WCLK_OUT 18 = ASI2_BCLK_OUT 19-20 = Reserved 21 = ASI2_DOUT 22-26 = Reserved 27 = ASIM_WCLK_OUT 28 = ASIM_BCLK_OUT 29 = ASIM_DOUT 30-31 = Reserved

14.2.65 GPIO8_PIN (book=0x00 page=0x01 address=0x44) [reset=0h]

Configures DIN2_GPIO8 pin.

Figure 111. GPIO8_PIN Register Address: 0x44

7	6	5	4	3	2	1	0
Reserved	GP8_VAL	Reserved	GP8_OUT[4:0]				
RW-0h	RW-0h	RW-0h	RW-0h				

LEGEND: R/W = Read/Write; R = Read only; -n = value after reset

Table 89. GPIO8 Field Descriptions

Bit	Field	Type	Reset	Description
7	Reserved	RW	0h	Reserved
6	GP8_VAL	RW	0h	When value GP8_OUT=3, configure pin output to 0 = Low 1 = High
5	Reserved	RW	0h	Reserved

Table 89. GPIO8 Field Descriptions (continued)

Bit	Field	Type	Reset	Description
4-0	GP8_OUT[4:0]	RW	0h	Pin is configured to 0 = disabled, buffers powered down 1 = input, use input MUX for relevant function 2 = Reserved 3 = output, use GP8_VAL to set value 4 = output, use GPBB_VAL to set value 5 = output, PDM clk output for PDM data input 6 = output, CLKOUT output 7 = output, INT1 interrupt 8 = output, INT2 interrupt 9 = output, INT3 interrupt 10 = output, INT4 interrupt 11 = Reserved 12 = output, ASI1_WCLK_OUT 13 = output, ASI1_BCLK_OUT 14-15 = Reserved 16 = ASI1_DOUT 17 = ASI1_WCLK_OUT 18 = ASI2_BCLK_OUT 19-20 = Reserved 21 = ASI2_DOUT 22-26 = Reserved 27 = ASIM_WCLK_OUT 28 = ASIM_BCLK_OUT 29 = ASIM_DOUT 30-31 = Reserved

14.2.66 GPIO9_PIN (book=0x00 page=0x01 address=0x45) [reset=0h]

Configures ICC_CLK_GPIO9 pin.

Figure 112. GPIO9_PIN Register Address: 0x45

7	6	5	4	3	2	1	0	
Reserved	GP9_VAL	Reserved	GP9_OUT[4:0]					
RW-0h	RW-0h	RW-0h	RW-0h					

LEGEND: R/W = Read/Write; R = Read only; -n = value after reset

Table 90. GPIO9 Field Descriptions

Bit	Field	Type	Reset	Description
7	Reserved	RW	0h	Reserved
6	GP9_VAL	RW	0h	When value GP9_OUT=3, configure pin output to 0 = Low 1 = High
5	Reserved	RW	0h	Reserved

Table 90. GPIO9 Field Descriptions (continued)

Bit	Field	Type	Reset	Description
4-0	GP9_OUT[4:0]	RW	0h	Pin is configured to 0 = disabled, buffers powered down 1 = input, use input MUX for relevant function 2 = Reserved 3 = output, use GP9_VAL to set value 4 = output, use GPBB_VAL to set value 5 = output, PDM clk output for PDM data input 6 = output, CLKOUT output 7 = output, INT1 interrupt 8 = output, INT2 interrupt 9 = output, INT3 interrupt 10 = output, INT4 interrupt 11 = Reserved 12 = output, ASI1_WCLK_OUT 13 = output, ASI1_BCLK_OUT 14-15 = Reserved 16 = ASI1_DOUT 17 = ASI1_WCLK_OUT 18 = ASI2_BCLK_OUT 19-20 = Reserved 21 = ASI2_DOUT 22-26 = Reserved 27 = ASIM_WCLK_OUT 28 = ASIM_BCLK_OUT 29 = ASIM_DOUT 30-31 = Reserved

14.2.67 GPIO10_PIN (book=0x00 page=0x01 address=0x46) [reset=0h]

Configures ICC_DOUT_GPIO10 pin.

Figure 113. GPIO10_PIN Register Address: 0x46

7	6	5	4	3	2	1	0
Reserved	GP10_VAL	Reserved	GP10_OUT[4:0]				
RW-0h	RW-0h	RW-0h	RW-0h				

LEGEND: R/W = Read/Write; R = Read only; -n = value after reset

Table 91. GPIO10 Field Descriptions

Bit	Field	Type	Reset	Description
7	Reserved	RW	0h	Reserved
6	GP10_VAL	RW	0h	When value GP10_OUT=3, configure pin output to 0 = Low 1 = High
5	Reserved	RW	0h	Reserved

Table 91. GPIO10 Field Descriptions (continued)

Bit	Field	Type	Reset	Description
4-0	GP10_OUT[4:0]	RW	0h	Pin is configured to 0 = disabled, buffers powered down 1 = input, use input MUX for relevant function 2 = Reserved 3 = output, use GP10_VAL to set value 4 = output, use GPBB_VAL to set value 5 = output, PDM clk output for PDM data input 6 = output, CLKOUT output 7 = output, INT1 interrupt 8 = output, INT2 interrupt 9 = output, INT3 interrupt 10 = output, INT4 interrupt 11 = Reserved 12 = output, ASI1_WCLK_OUT 13 = output, ASI1_BCLK_OUT 14-15 = Reserved 16 = ASI1_DOUT 17 = ASI1_WCLK_OUT 18 = ASI2_BCLK_OUT 19-20 = Reserved 21 = ASI2_DOUT 22-26 = Reserved 27 = ASIM_WCLK_OUT 28 = ASIM_BCLK_OUT 29 = ASIM_DOUT 30-31 = Reserved

14.2.68 GPI_PIN (book=0x00 page=0x01 address=0x4D) [reset=0h]

Configures the GPI pins

Figure 114. GPI_PIN Register Address: 0x4D

7	6	5	4	3	2	1	0
Reserved		GPI3_MODE[1:0]		GPI2_MODE[1:0]		GPI1_MODE[1:0]	
RW-0h		RW-0h		RW-0h		RW-0h	

LEGEND: R/W = Read/Write; R = Read only; -n = value after reset

Table 92. GPI Pin Mode Field Descriptions

Bit	Field	Type	Reset	Description
7-6	Reserved	RW	0h	Reserved
5-4	GPI3_MODE[1:0]	RW	0h	Pin GPI3 mode is 0 = disabled, powered down 1 = input, use input MUX for relevant function 2 = Reserved 3 = Reserved
3-2	GPI2_MODE[1:0]	RW	0h	Pin GPI2 mode is 0 = disabled, powered down 1 = input, use input MUX for relevant function 2 = Reserved 3 = Reserved
1-0	GPI1_MODE[1:0]	RW	0h	Pin GPI1 mode is 0 = disabled, powered down 1 = input, use input MUX for relevant function 2 = Reserved 3 = Reserved

14.2.69 GPIO_HIZ_1 (book=0x00 page=0x01 address=0x4F) [reset=0h]

Configures high-Z state of GPIO1 and GPIO2

Figure 115. GPIO_HIZ_1 Register Address: 0x4F

7	6	5	4	3	2	1	0
Reserved	GP2_HIZ[2:0]			Reserved	GP1_HIZ[2:0]		
RW-0h	RW-0h			RW-0h	RW-0h		

LEGEND: R/W = Read/Write; R = Read only; -n = value after reset

Table 93. GPIO HiZ 1 Field Descriptions

Bit	Field	Type	Reset	Description
7	Reserved	RW	0h	Reserved
6-4	GP2_HIZ[2:0]	RW	0h	Pin GPIO2 output is 0 = driven both LO/HI 1 = driven both LO/HI with buskeeper for use with outputs needing tri-stated 2 = Reserved 3 = Reserved 4 = Reserved 5 = Reserved 6 = Reserved 7 = Reserved
3	Reserved	RW	0h	Reserved
2-0	GP1_HIZ[2:0]	RW	0h	Pin GPIO1 output is 0 = driven both LO/HI 1 = driven both LO/HI with buskeeper for use with outputs needing tri-stated 2 = Reserved 3 = Reserved 4 = Reserved 5 = Reserved 6 = Reserved 7 = Reserved

14.2.70 GPIO_HIZ_2 (book=0x00 page=0x01 address=0x50) [reset=0h]

Configures high-Z state of GPIO3 and GPIO4

Figure 116. GPIO_HIZ_2 Register Address: 0x50

7	6	5	4	3	2	1	0
Reserved	GP4_HIZ[2:0]			Reserved	GP3_HIZ[2:0]		
RW-0h	RW-0h			RW-0h	RW-0h		

LEGEND: R/W = Read/Write; R = Read only; -n = value after reset

Table 94. GPIO HiZ 2 Field Descriptions

Bit	Field	Type	Reset	Description
7	Reserved	RW	0h	Reserved
6-4	GP4_HIZ[2:0]	RW	0h	Pin GPIO4 output is 0 = driven both LO/HI 1 = driven both LO/HI with buskeeper for use with outputs needing tri-stated 2 = Reserved 3 = Reserved 4 = Reserved 5 = Reserved 6 = Reserved 7 = Reserved
3	Reserved	RW	0h	Reserved

Table 94. GPIO HiZ 2 Field Descriptions (continued)

Bit	Field	Type	Reset	Description
2-0	GP3_HIZ[2:0]	RW	0h	Pin GPIO3 output is 0 = driven both LO/HI 1 = driven both LO/HI with buskeeper for use with outputs needing tri-stated 2 = Reserved 3 = Reserved 4 = Reserved 5 = Reserved 6 = Reserved 7 = Reserved

14.2.71 GPIO_HIZ_3 (book=0x00 page=0x01 address=0x51) [reset=0h]

Configures high-Z state of GPIO5 and GPIO6

Figure 117. GPIO_HIZ_3 Register Address: 0x51

7	6	5	4	3	2	1	0
Reserved	GP6_HIZ[2:0]			Reserved	GP5_HIZ[2:0]		
RW-0h	RW-0h			RW-0h	RW-0h		

LEGEND: R/W = Read/Write; R = Read only; -n = value after reset

Table 95. GPIO HiZ 3 Field Descriptions

Bit	Field	Type	Reset	Description
7	Reserved	RW	0h	Reserved
6-4	GP6_HIZ[2:0]	RW	0h	Pin GPIO6 output is 0 = driven both LO/HI 1 = driven both LO/HI with buskeeper for use with outputs needing tri-stated 2 = Reserved 3 = Reserved 4 = Reserved 5 = Reserved 6 = Reserved 7 = Reserved
3	Reserved	RW	0h	Reserved
2-0	GP5_HIZ[2:0]	RW	0h	Pin GPIO5 output is 0 = driven both LO/HI 1 = driven both LO/HI with buskeeper for use with outputs needing tri-stated 2 = Reserved 3 = Reserved 4 = Reserved 5 = Reserved 6 = Reserved 7 = Reserved

14.2.72 GPIO_HIZ_4 (book=0x00 page=0x01 address=0x52) [reset=0h]

Configures high-Z state of GPIO7 and GPIO8

Figure 118. GPIO_HIZ_4 Register Address: 0x52

7	6	5	4	3	2	1	0
Reserved	GP8_HIZ[2:0]			Reserved	GP7_HIZ[2:0]		
RW-0h	RW-0h			RW-0h	RW-0h		

LEGEND: R/W = Read/Write; R = Read only; -n = value after reset

Table 96. GPIO HiZ 4 Field Descriptions

Bit	Field	Type	Reset	Description
7	Reserved	RW	0h	Reserved
6-4	GP8_HIZ[2:0]	RW	0h	Pin GPIO8 output is 0 = driven both LO/HI 1 = driven both LO/HI with buskeeper for use with outputs needing tri-stated 2 = Reserved 3 = Reserved 4 = Reserved 5 = Reserved 6 = Reserved 7 = Reserved
3	Reserved	RW	0h	Reserved
2-0	GP7_HIZ[2:0]	RW	0h	Pin GPIO7 output is 0 = driven both LO/HI 1 = driven both LO/HI with buskeeper for use with outputs needing tri-stated 2 = Reserved 3 = Reserved 4 = Reserved 5 = Reserved 6 = Reserved 7 = Reserved

14.2.73 GPIO_HIZ_5 (book=0x00 page=0x01 address=0x53) [reset=0h]

Configures high-Z state of GPIO9 and GPIO10

Figure 119. GPIO_HIZ_5 Register Address: 0x53

7	6	5	4	3	2	1	0
Reserved	GP10_HIZ[2:0]			Reserved	GP9_HIZ[2:0]		
RW-0h	RW-0h			RW-0h	RW-0h		

LEGEND: R/W = Read/Write; R = Read only; -n = value after reset

Table 97. GPIO HiZ 5 Field Descriptions

Bit	Field	Type	Reset	Description
7	Reserved	RW	0h	Reserved
6-4	GP10_HIZ[2:0]	RW	0h	Pin GPIO10 output is 0 = driven both LO/HI 1 = driven both LO/HI with buskeeper for use with outputs needing tri-stated 2 = Reserved 3 = Reserved 4 = Reserved 5 = Reserved 6 = Reserved 7 = Reserved
3	Reserved	RW	0h	Reserved
2-0	GP9_HIZ[2:0]	RW	0h	Pin GPIO9 output is 0 = driven both LO/HI 1 = driven both LO/HI with buskeeper for use with outputs needing tri-stated 2 = Reserved 3 = Reserved 4 = Reserved 5 = Reserved 6 = Reserved 7 = Reserved

14.2.74 BIT_BANG_OUT1 (book=0x00 page=0x01 address=0x58) [reset=0h]

GPIO pin state when using bit-bang output.

Figure 120. BIT_BANG_OUT1 Register Address: 0x58

7	6	5	4	3	2	1	0
BBO_GP8	BBO_GP7	BBO_GP6	BBO_GP5	BBO_GP4	BBO_GP3	BBO_GP2	BBO_GP1
RW-0h	RW-0h	RW-0h	RW-0h	RW-0h	RW-0h	RW-0h	RW-0h

LEGEND: R/W = Read/Write; R = Read only; -n = value after reset

Table 98. Bit Bang Output 1 Field Descriptions

Bit	Field	Type	Reset	Description
7	BBO_GP8	RW	0h	GPIO8 pin output is 0 = low 1 = high
6	BBO_GP7	RW	0h	GPIO7 pin output is 0 = low 1 = high
5	BBO_GP6	RW	0h	GPIO6 pin output is 0 = low 1 = high
4	BBO_GP5	RW	0h	GPIO5 pin output is 0 = low 1 = high
3	BBO_GP4	RW	0h	GPIO4 pin output is 0 = low 1 = high
2	BBO_GP3	RW	0h	GPIO3 pin output is 0 = low 1 = high
1	BBO_GP2	RW	0h	GPIO2 pin output is 0 = low 1 = high
0	BBO_GP1	RW	0h	GPIO1 pin output is 0 = low 1 = high

14.2.75 BIT_BANG_OUT2 (book=0x00 page=0x01 address=0x59) [reset=0h]

GPIO pin state when using pin as bit-bang output.

Figure 121. BIT_BANG_OUT2 Register Address: 0x59

7	6	5	4	3	2	1	0
Reserved						BBO_GP10	BBO_GP9
RW-0h						RW-0h	RW-0h

LEGEND: R/W = Read/Write; R = Read only; -n = value after reset

Table 99. Bit Bang Output 2 Field Descriptions

Bit	Field	Type	Reset	Description
7-2	Reserved	RW	0h	Reserved
1	BBO_GP10	RW	0h	GPIO10 pin output is 0 = low 1 = high
0	BBO_GP9	RW	0h	GPIO9 pin output is 0 = low 1 = high

14.2.76 BIT_BANG_IN1 (book=0x00 page=0x01 address=0x5A) [reset=0h]

GPIO pin value when used as bit-bang input.

Figure 122. BIT_BANG_IN1 Register Address: 0x5A

7	6	5	4	3	2	1	0
BBI_GP8	BBI_GP7	BBI_GP6	BBI_GP5	BBI_GP4	BBI_GP3	BBI_GP2	BBI_GP1
R-0h	R-0h	R-0h	R-0h	R-0h	R-0h	R-0h	R-0h

LEGEND: R/W = Read/Write; R = Read only; -n = value after reset

Table 100. Bit Bang Input 1 Field Descriptions

Bit	Field	Type	Reset	Description
7	BBI_GP8	R	0h	GPIO8 pin input is 0 = low 1 = high
6	BBI_GP7	R	0h	GPIO7 pin input is 0 = low 1 = high
5	BBI_GP6	R	0h	GPIO6 pin input is 0 = low 1 = high
4	BBI_GP5	R	0h	GPIO5 pin input is 0 = low 1 = high
3	BBI_GP4	R	0h	GPIO4 pin input is 0 = low 1 = high
2	BBI_GP3	R	0h	GPIO3 pin input is 0 = low 1 = high
1	BBI_GP2	R	0h	GPIO2 pin input is 0 = low 1 = high
0	BBI_GP1	R	0h	GPIO1 pin input is 0 = low 1 = high

14.2.77 BIT_BANG_IN2 (book=0x00 page=0x01 address=0x5B) [reset=0h]

GPIO pin value when used as bit-bang input.

Figure 123. BIT_BANG_IN2 Register Address: 0x5B

7	6	5	4	3	2	1	0
Reserved						BBI_GP10	BBI_GP9
RW-0h						RW-0h	RW-0h

LEGEND: R/W = Read/Write; R = Read only; -n = value after reset

Table 101. Bit Bang Input 2 Field Descriptions

Bit	Field	Type	Reset	Description
7-2	Reserved	RW	0h	Reserved
1	BBI_GP10	RW	0h	GPIO10 pin input is 0 = low 1 = high
0	BBI_GP9	RW	0h	GPIO9 pin input is 0 = low 1 = high

14.2.78 BIT_BANG_IN3 (book=0x00 page=0x01 address=0x5C) [reset=0h]

GPI pin value when used as bit-bang input.

Figure 124. BIT_BANG_IN3 Register Address: 0x5C

7	6	5	4	3	2	1	0
Reserved					BBI_GPI3	BBI_GPI2	BBI_GPI1
RW-0h					RW-0h	RW-0h	RW-0h

LEGEND: R/W = Read/Write; R = Read only; -n = value after reset

Table 102. Bit Bang Input 3 Field Descriptions

Bit	Field	Type	Reset	Description
7-3	Reserved	RW	0h	Reserved
2	BBI_GPI3	RW	0h	GPI3 pin input is 0 = low 1 = high
1	BBI_GPI2	RW	0h	GPI2 pin input is 0 = low 1 = high
0	BBI_GPI1	RW	0h	GPI1 pin input is 0 = low 1 = high

14.2.79 ASIM_BUSKEEP (book=0x00 page=0x01 address=0x60) [reset=0h]

Configures the buskeeper operation.

Figure 125. ASIM_BUSKEEP Register Address: 0x60

7	6	5	4	3	2	1	0
ASIM_BKP	Reserved						
RW-0h	RW-0h						

LEGEND: R/W = Read/Write; R = Read only; -n = value after reset

Table 103. ASIM Buskeeper Field Descriptions

Bit	Field	Type	Reset	Description
7	ASIM_BKP	RW	0h	Bus keep power down when DOUT is tri-stated to save IO power is 0 = disabled 1 = enabled
6-0	Reserved	RW	0h	Reserved

14.2.80 ASIM_MODE (book=0x00 page=0x01 address=0x61) [reset=8h]

specifies the format and slots for the Interchip Communication (ICC) Interface

Figure 126. ASIM_MODE Register Address: 0x61

7	6	5	4	3	2	1	0
ASIM_INT	Reserved	ASIM_WCNT[3:0]				ASIM_RS	ASIM_WS
RW-0h	RW-0h	RW-2h				RW-0h	RW-0h

LEGEND: R/W = Read/Write; R = Read only; -n = value after reset

Table 104. ASIM Mode Field Descriptions

Bit	Field	Type	Reset	Description
7	ASIM_INT	RW	0h	ASIM interface is 0 = Non-ICC set by ASIM_FORMAT 1 = ICC interface for multichip
6	Reserved	RW	0h	Reserved

Table 104. ASIM Mode Field Descriptions (continued)

Bit	Field	Type	Reset	Description
5-2	ASIM_WCNT[3:0]	RW	2h	The number of words(32-bit samples) in one frame of the ICC. The total number of bit transmitted is (1+words)*33 0 = Reserved 1 = 1 word 2 = 2 words ... 13 = 13 words 14 = 14 words 15 = Reserved
1	ASIM_RS	RW	0h	The device will read the following ICC slots and transfer data to DSP 0 = only it own slot 1 = all slots
0	ASIM_WS	RW	0h	The device will write the following ICC slots and transfer data to DSP 0 = only it own slot 1 = all slots

14.2.81 ASIM_NUM_DEV (book=0x00 page=0x01 address=0x62) [reset=0h]

specifies the number of devices on the Interchip Communication (ICC) Interface

Figure 127. ASIM_NUM_DEV Register Address: 0x62

7	6	5	4	3	2	1	0
Reserved	ASIM_TND[2:0]			Reserved	ASIM_DN[2:0]		
RW-0h	RW-0h			RW-0h	RW-0h		

LEGEND: R/W = Read/Write; R = Read only; -n = value after reset

Table 105. ASIM Number Devices Field Descriptions

Bit	Field	Type	Reset	Description
7	Reserved	RW	0h	Reserved
6-4	ASIM_TND[2:0]	RW	0h	Total number of devices on the ICC interface bus 0 = 8 1 = 1 2 = 2 ... 6 = 6 7 = 7
3	Reserved	RW	0h	Reserved
2-0	ASIM_DN[2:0]	RW	0h	The device number for this device on the ICC interface bus 0 = 1 1 = 2 ... 6 = 7 7 = 8

14.2.82 ASIM_FORMAT (book=0x00 page=0x01 address=0x63) [reset=10h]

Configures the ASI2 format, wordlength, and tristate.

Figure 128. ASIM_FORMAT Register Address: 0x63

7	6	5	4	3	2	1	0
ASIM_MODE[2:0]			ASI2_LENGTH[1:0]		Reserved		ASI2_TRISTATE
RW-0h			RW-2h		RW-0h		RW-0h

LEGEND: R/W = Read/Write; R = Read only; -n = value after reset

Table 106. ASIM Format Field Descriptions

Bit	Field	Type	Reset	Description
7-5	ASIM_MODE[2:0]	RW	0h	The ASIM Input mode format is set to 0 = I2S 1 = DSP 2 = RJF , For non-zero values of ASIM_OFFSET1, LJF is preferred 3 = LJF 4 = MonoPCM 5-15 = Reserved
4-3	ASI2_LENGTH[1:0]	RW	2h	Sets the ASIM input word-length to 0 = 16bits 1 = 20bits 2 = 24bits 3 = 32bits
2-1	Reserved	RW	0h	Reserved
0	ASI2_TRISTATE	RW	0h	Tri-stating of DOUT for the extra ASIM_BCLK cycles after Data Transfer is over for a frame is 0 = Disabled 1 = Enabled

14.2.83 ASIM_BDIV_CLK (book=0x00 page=0x01 address=0x64) [reset=1h]

Selects the BDIV clock source and input/output mode for WCLK/BCLK.

Figure 129. ASIM_BDIV_CLK Register Address: 0x64

7	6	5	4	3	2	1	0
ASIM_BCD	ASIM_WCD	Reserved			ASIM_BDIV_SRC[2:0]		
RW-0h	RW-0h	RW-0h			RW-1h		

LEGEND: R/W = Read/Write; R = Read only; -n = value after reset

Table 107. ASIM BDIV Clock Field Descriptions

Bit	Field	Type	Reset	Description
7	ASIM_BCD	RW	0h	ASIM BCLK is 0 = input 1 = output; use only in ICC mode if device number is 1
6	ASIM_WCD	RW	0h	ASIM WCLK is 0 = input 1 = output
5-3	Reserved	RW	0h	Reserved
2-0	ASIM_BDIV_SRC[2:0]	RW	1h	ASIM bit clock divider (BDIV) source is 0 = NDIV_CLK (Generated On-Chip) 1 = DAC_MOD_CLK (Generated On-Chip) 2 = Reserved 3 = ADC_MOD_CLK (Generated On-Chip) 4 = ASI1_DAC_BCLK (at pin) 5 = ASI1_ADC_BCLK (at pin) 6 = ASI2_DAC_BCLK (at pin) 7 = ASI2_ADC_BCLK (at pin)

14.2.84 ASIM_BDIV_RATIO (book=0x00 page=0x01 address=0x65) [reset=2h]

Configure the BDIV ratio and power.

Figure 130. ASIM_BDIV_RATIO Register Address: 0x65

7	6	5	4	3	2	1	0
ASIM_BDIV_P WR	ASIM_BDIV_RTO[6:0]						
RW-0h	RW-2h						

LEGEND: R/W = Read/Write; R = Read only; -n = value after reset

Table 108. ASIM BDIV Ratio Field Descriptions

Bit	Field	Type	Reset	Description
7	ASIM_BDIV_PWR	RW	0h	The ASIM BDIV divider is 0 = powered down 1 = powered up
6-0	ASIM_BDIV_RTO[6:0]	RW	2h	The ASIM BDIV ratio is 0 = 128 1 = 1 2 = 2 ... 126 = 126 127 = 127

14.2.85 ASIM_WDIV_RATIO_1 (book=0x00 page=0x01 address=0x66) [reset=0h]

Configure the WDIV ratio and power.

Figure 131. ASIM_WDIV_RATIO_1 Register Address: 0x66

7	6	5	4	3	2	1	0
ASIM_WDIV_PWR	Reserved					ASIM_WDIV_RTO[9:8]	
RW-0h	RW-0h					RW-0h	

LEGEND: R/W = Read/Write; R = Read only; -n = value after reset

Table 109. ASIM WDIV Ratio Field Descriptions

Bit	Field	Type	Reset	Description
7	ASIM_WDIV_PWR	RW	0h	The ASIM WDIV divider is 0 = powered down 1 = powered up
6-2	Reserved	RW	0h	Reserved
1--8	ASIM_WDIV_RTO[9:0]	RW	0h	MSB for ASIM WDIV divider

14.2.86 ASIM_WDIV_RATIO_2 (book=0x00 page=0x01 address=0x67) [reset=20h]

Configure the WDIV ratio.

Figure 132. ASIM_WDIV_RATIO_2 Register Address: 0x67

7	6	5	4	3	2	1	0
ASIM_WDIV_RTO[7:0]							
RW-20h							

LEGEND: R/W = Read/Write; R = Read only; -n = value after reset

Table 110. ASIM WDIV Ratio Field Descriptions

Bit	Field	Type	Reset	Description
7-0	ASIM_WDIV_RTO[7:0]	RW	20h	LSB for ASIM WDIV. Number for ASIM_BDIV clock cycles in on ASIM_WCLK frame 0 = 1024 1 = 1 2 = 2 ... 1022 = 1022 1023 = 1023

14.2.87 ASIM_BCLK (book=0x00 page=0x01 address=0x68) [reset=40h]

Configures the bit clock pin.

Figure 133. ASIM_BCLK Register Address: 0x68

7	6	5	4	3	2	1	0
Reserved	ASIM_BCLK[3:0]				Reserved		
RW-0h	RW-8h				RW-0h		

LEGEND: R/W = Read/Write; R = Read only; -n = value after reset

Table 111. ASIM BCLK Field Descriptions

Bit	Field	Type	Reset	Description
7	Reserved	RW	0h	Reserved
6-3	ASIM_BCLK[3:0]	RW	8h	ASIM BCLK input is from 0 = GPIO1 1 = GPIO2 2 = GPIO3 3 = GPIO4 4 = GPIO5 5 = GPIO6 6 = GPIO7 7 = GPIO8 8 = GPIO9 (Preferred pin usage) 9 = GPIO10 10-11 = Reserved 12 = GPI1 13 = GPI2 14 = GPI3 15-31 = Reserved
2-0	Reserved	RW	0h	Reserved

14.2.88 ASIM_WCLK (book=0x00 page=0x01 address=0x69) [reset=38h]

Configures the word clock pin.

Figure 134. ASIM_WCLK Register Address: 0x69

7	6	5	4	3	2	1	0
Reserved	ASIM_WCLK[3:0]				Reserved		
RW-0h	RW-7h				RW-0h		

LEGEND: R/W = Read/Write; R = Read only; -n = value after reset

Table 112. ASIM WCLK Field Descriptions

Bit	Field	Type	Reset	Description
7	Reserved	RW	0h	Reserved
6-3	ASIM_WCLK[3:0]	RW	7h	ASIM BCLK input is from 0 = GPIO1 1 = GPIO2 2 = GPIO3 3 = GPIO4 4 = GPIO5 5 = GPIO6 6 = GPIO7 7 = GPIO8 (Preferred pin usage) 8 = GPIO9 9 = GPIO10 10-11 = Reserved 12 = GPI1 13 = GPI2 14 = GPI3 15-31 = Reserved
2-0	Reserved	RW	0h	Reserved

14.2.89 ASIM_DIN (book=0x00 page=0x01 address=0x6A) [reset=70h]

Configures the ASIM data input pin and clock detection 2 interrupt generation.

Figure 135. ASIM_DIN Register Address: 0x6A

7	6	5	4	3	2	1	0
Reserved	ASIM_DIN[3:0]			INT_GEN_CH2[2:0]			
RW-0h	RW-Eh			RW-0h			

LEGEND: R/W = Read/Write; R = Read only; -n = value after reset

Table 113. AS11 DIN Field Descriptions

Bit	Field	Type	Reset	Description
7	Reserved	RW	0h	Reserved
6-3	ASIM_DIN[3:0]	RW	Eh	ASIM BCLK input is from 0 = GPIO1 1 = GPIO2 2 = GPIO3 3 = GPIO4 4 = GPIO5 5 = GPIO6 6 = GPIO7 7 = GPIO8 8 = GPIO9 9 = GPIO10 10-11 = Reserved 12 = GPI1 13 = GPI2 14 = GPI3 (Preferred pin usage) 15-31 = Reserved
2-0	INT_GEN_CH2[2:0]	RW	0h	Clock halt detection 2 is 0 = not used in the generation of interrupt 1 = used in the generation of INT1 2 = used in the generation of INT2 3 = used in the generation of INT3 4 = used in the generation of INT4 5-7 = Reserved

14.2.90 INT_GEN_1 (book=0x00 page=0x01 address=0x6C) [reset=0h]

Assign speaker over-current and device over-voltage to specific interrupt

Figure 136. INT_GEN_1 Register Address: 0x6C

7	6	5	4	3	2	1	0
Reserved	INT_GEN_OC[2:0]			Reserved	INT_GEN_OV[2:0]		
RW-0h	RW-0h			RW-0h	RW-0h		

LEGEND: R/W = Read/Write; R = Read only; -n = value after reset

Table 114. Interrupt Generation 1 Field Descriptions

Bit	Field	Type	Reset	Description
7	Reserved	RW	0h	Reserved
6-4	INT_GEN_OC[2:0]	RW	0h	Speaker over current is 0 = not used in the generation of interrupt 1 = used in the generation of INT1 2 = used in the generation of INT2 3 = used in the generation of INT3 4 = used in the generation of INT4 5-7 = Reserved
3	Reserved	RW	0h	Reserved

Table 114. Interrupt Generation 1 Field Descriptions (continued)

Bit	Field	Type	Reset	Description
2-0	INT_GEN_OV[2:0]	RW	0h	Device over voltage is 0 = not used in the generation of interrupt 1 = used in the generation of INT1 2 = used in the generation of INT2 3 = used in the generation of INT3 4 = used in the generation of INT4 5-7 = Reserved

14.2.91 INT_GEN_2 (book=0x00 page=0x01 address=0x6D) [reset=0h]

Assign clock error deteciton 1 and die over temperature to specific interrupt

Figure 137. INT_GEN_2 Register Address: 0x6D

7	6	5	4	3	2	1	0
Reserved	INT_GEN_CE1[2:0]			Reserved	INT_GEN_OT[2:0]		
RW-0h	RW-0h			RW-0h	RW-0h		

LEGEND: R/W = Read/Write; R = Read only; -n = value after reset

Table 115. Interrupt Generation 2 Field Descriptions

Bit	Field	Type	Reset	Description
7	Reserved	RW	0h	Reserved
6-4	INT_GEN_CE1[2:0]	RW	0h	Clock error detection 1 is 0 = not used in the generation of interrupt 1 = used in the generation of INT1 2 = used in the generation of INT2 3 = used in the generation of INT3 4 = used in the generation of INT4 5-7 = Reserved
3	Reserved	RW	0h	Reserved
2-0	INT_GEN_OT[2:0]	RW	0h	Die over-temperature is 0 = not used in the generation of interrupt 1 = used in the generation of INT1 2 = used in the generation of INT2 3 = used in the generation of INT3 4 = used in the generation of INT4 5-7 = Reserved

14.2.92 INT_GEN_3 (book=0x00 page=0x01 address=0x6E) [reset=0h]

Assign clock error deteciton 2 and brownout to specific interrupt

Figure 138. INT_GEN_3 Register Address: 0x6E

7	6	5	4	3	2	1	0
Reserved	INT_GEN_BO[2:0]			Reserved	INT_GEN_CE2[2:0]		
RW-0h	RW-0h			RW-0h	RW-0h		

LEGEND: R/W = Read/Write; R = Read only; -n = value after reset

Table 116. Interrupt Generation 3 Field Descriptions

Bit	Field	Type	Reset	Description
7	Reserved	RW	0h	Reserved
6-4	INT_GEN_BO[2:0]	RW	0h	Device brownout is 0 = not used in the generation of interrupt 1 = used in the generation of INT1 2 = used in the generation of INT2 3 = used in the generation of INT3 4 = used in the generation of INT4 5-7 = Reserved

Table 116. Interrupt Generation 3 Field Descriptions (continued)

Bit	Field	Type	Reset	Description
3	Reserved	RW	0h	Reserved
2-0	INT_GEN_CE2[2:0]	RW	0h	Clock error detection 2 is 0 = not used in the generation of interrupt 1 = used in the generation of INT1 2 = used in the generation of INT2 3 = used in the generation of INT3 4 = used in the generation of INT4 5-7 = Reserved

14.2.93 INT_GEN_4 (book=0x00 page=0x01 address=0x6F) [reset=0h]

Assign SAR complete and clock halt 1 to specific interrupt

Figure 139. INT_GEN_4 Register Address: 0x6F

7	6	5	4	3	2	1	0
Reserved	INT_GEN_SC[2:0]			Reserved	INT_GEN_CL[2:0]		
RW-0h	RW-0h			RW-0h	RW-0h		

LEGEND: R/W = Read/Write; R = Read only; -n = value after reset

Table 117. Interrupt Generation 4 Field Descriptions

Bit	Field	Type	Reset	Description
7	Reserved	RW	0h	Reserved
6-4	INT_GEN_SC[2:0]	RW	0h	SAR measurement complete is 0 = not used in the generation of interrupt 1 = used in the generation of INT1 2 = used in the generation of INT2 3 = used in the generation of INT3 4 = used in the generation of INT4 5-7 = Reserved
3	Reserved	RW	0h	Reserved
2-0	INT_GEN_CL[2:0]	RW	0h	Clock lost halt 1 is 0 = not used in the generation of interrupt 1 = used in the generation of INT1 2 = used in the generation of INT2 3 = used in the generation of INT3 4 = used in the generation of INT4 5-7 = Reserved

14.2.94 INT_GEN_5 (book=0x00 page=0x01 address=0x70) [reset=0h]

Assign DSP Interrupt 1 and DSP interrupt 2 to specific interrupt

Figure 140. INT_GEN_5 Register Address: 0x70

7	6	5	4	3	2	1	0
Reserved	INT_GEN_DSP1[2:0]			Reserved	INT_GEN_DSP2[2:0]		
RW-0h	RW-0h			RW-0h	RW-0h		

LEGEND: R/W = Read/Write; R = Read only; -n = value after reset

Table 118. Interrupt Generation 5 Field Descriptions

Bit	Field	Type	Reset	Description
7	Reserved	RW	0h	Reserved
6-4	INT_GEN_DSP1[2:0]	RW	0h	DSP output interrupt 1 is 0 = not used in the generation of interrupt 1 = used in the generation of INT1 2 = used in the generation of INT2 3 = used in the generation of INT3 4 = used in the generation of INT4 5-7 = Reserved
3	Reserved	RW	0h	Reserved
2-0	INT_GEN_DSP2[2:0]	RW	0h	DSP output interrupt 2 is 0 = not used in the generation of interrupt 1 = used in the generation of INT1 2 = used in the generation of INT2 3 = used in the generation of INT3 4 = used in the generation of INT4 5-7 = Reserved

14.2.95 INT_GEN_6 (book=0x00 page=0x01 address=0x71) [reset=0h]

Assign DSP Interrupt 3 and DSP interrupt 4 to specific interrupt

Figure 141. INT_GEN_6 Register Address: 0x71

7	6	5	4	3	2	1	0
Reserved	INT_GEN_DSP3[2:0]			Reserved	INT_GEN_DSP4[2:0]		
RW-0h	RW-0h			RW-0h	RW-0h		

LEGEND: R/W = Read/Write; R = Read only; -n = value after reset

Table 119. Interrupt Generation 6 Field Descriptions

Bit	Field	Type	Reset	Description
7	Reserved	RW	0h	Reserved
6-4	INT_GEN_DSP3[2:0]	RW	0h	DSP output interrupt 3 is 0 = not used in the generation of interrupt 1 = used in the generation of INT1 2 = used in the generation of INT2 3 = used in the generation of INT3 4 = used in the generation of INT4 5-7 = Reserved
3	Reserved	RW	0h	Reserved
2-0	INT_GEN_DSP4[2:0]	RW	0h	DSP output interrupt 4 is 0 = not used in the generation of interrupt 1 = used in the generation of INT1 2 = used in the generation of INT2 3 = used in the generation of INT3 4 = used in the generation of INT4 5-7 = Reserved

14.2.96 INT_IND_MODE (book=0x00 page=0x01 address=0x72) [reset=0h]

Configure how interrupts are reported.

Figure 142. INT_IND_MODE Register Address: 0x72

7	6	5	4	3	2	1	0
INT1_IND[1:0]		INT2_IND[1:0]		INT3_IND[1:0]		INT4_IND[1:0]	
RW-0h		RW-0h		RW-0h		RW-0h	

LEGEND: R/W = Read/Write; R = Read only; -n = value after reset

Table 120. Interrupt Indication Mode Field Descriptions

Bit	Field	Type	Reset	Description
7-6	INT1_IND[1:0]	RW	0h	Interrupt 1 pin will indicate an interrupt as 0 = one active high pulse of duration 2 ms 1 = multiple active high pulses of duration 2 ms with period 4 ms until INT_STICKY_1 and INT_STICKY_2 are read to be cleared. 2 = active high until INT_STICKY_1 and INT_STICKY_2 are read to be cleared. 2 = active high based instantaneous interrupt value
5-4	INT2_IND[1:0]	RW	0h	Interrupt 2 pin will indicate an interrupt as 0 = one active high pulse of duration 2 ms 1 = multiple active high pulses of duration 2 ms with period 4 ms until INT_STICKY_1 and INT_STICKY_2 are read to be cleared. 2 = active high until INT_STICKY_1 and INT_STICKY_2 are read to be cleared. 2 = active high based instantaneous interrupt value
3-2	INT3_IND[1:0]	RW	0h	Interrupt 3 pin will indicate an interrupt as 0 = one active high pulse of duration 2 ms 1 = multiple active high pulses of duration 2 ms with period 4 ms until INT_STICKY_1 and INT_STICKY_2 are read to be cleared. 2 = active high until INT_STICKY_1 and INT_STICKY_2 are read to be cleared. 2 = active high based instantaneous interrupt value
1-0	INT4_IND[1:0]	RW	0h	Interrupt 4 pin will indicate an interrupt as 0 = one active high pulse of duration 2 ms 1 = multiple active high pulses of duration 2 ms with period 4 ms until INT_STICKY_1 and INT_STICKY_2 are read to be cleared. 2 = active high until INT_STICKY_1 and INT_STICKY_2 are read to be cleared. 2 = active high based instantaneous interrupt value

14.2.97 MAIN_CLK_PIN (book=0x00 page=0x01 address=0x73) [reset=Dh]

Configures the main clock input source.

Figure 143. MAIN_CLK_PIN Register Address: 0x73

7	6	5	4	3	2	1	0
Reserved				MAIN_CLK_DIN[3:0]			
RW-0h				RW-Dh			

LEGEND: R/W = Read/Write; R = Read only; -n = value after reset

Table 121. Main Clock Source Field Descriptions

Bit	Field	Type	Reset	Description
7-4	Reserved	RW	0h	Reserved
3-0	MAIN_CLK_DIN[3:0]	RW	Dh	NDIV_MUX_CLKIN input is from 0 = GPIO1 1 = GPIO2 2 = GPIO3 3 = GPIO4 4 = GPIO5 5 = GPIO6 6 = GPIO7 7 = GPIO8 8 = GPIO9 9 = GPIO10 10-11 = Reserved 12 = GPI1 13 = GPI2 (Preferred pin usage) 14 = GPI3 15 = PLL_CLK generated on-cchip

14.2.98 PLL_CLK_PIN (book=0x00 page=0x01 address=0x74) [reset=Dh]

Configures the PLL clock input source.

Figure 144. PLL_CLK_PIN Register Address: 0x74

7	6	5	4	3	2	1	0
Reserved				PLL_CLK_DIN[3:0]			
RW-0h				RW-Dh			

LEGEND: R/W = Read/Write; R = Read only; -n = value after reset

Table 122. PLL Clock Source Field Descriptions

Bit	Field	Type	Reset	Description
7-4	Reserved	RW	0h	Reserved
3-0	PLL_CLK_DIN[3:0]	RW	Dh	PLL_CLKIN input is from 0 = GPIO1 1 = GPIO2 2 = GPIO3 3 = GPIO4 4 = GPIO5 5 = GPIO6 6 = GPIO7 7 = GPIO8 8 = GPIO9 9 = GPIO10 10-11 = Reserved 12 = GPI1 13 = GPI2 (Preferred pin usage) 14 = GPI3 15 = from internal oscillator

14.2.99 CLKOUT_MUX (book=0x00 page=0x01 address=0x75) [reset=Dh]

Configures the CDIV_CLKIN clock input source.

Figure 145. CLKOUT_MUX Register Address: 0x75

7	6	5	4	3	2	1	0
Reserved				CLKOUT_DIN[4:0]			
RW-0h				RW-Dh			

LEGEND: R/W = Read/Write; R = Read only; -n = value after reset

Table 123. CDIV_CLKIN Clock Source Field Descriptions

Bit	Field	Type	Reset	Description
7-5	Reserved	RW	0h	Reserved
4-0	CLKOUT_DIN[4:0]	RW	Dh	CDIV_CLKIN input is from 0 = GPIO1 1 = GPIO2 2 = GPIO3 3 = GPIO4 4 = GPIO5 5 = GPIO6 6 = GPIO7 7 = GPIO8 8 = GPIO9 9 = GPIO10 10-11 = Reserved 12 = GPI1 13 = GPI2 (Preferred pin usage) 14 = GPI3 15 = PLL_CLK 16 = DAC_MOD_CLK 17 = ADC_MOD_CLK 18 = NDIV_CLK 19-31 = Reserved

14.2.100 CLKOUT_CDIV_RATIO (book=0x00 page=0x01 address=0x76) [reset=1h]

Configure the CDIV ratio and power.

Figure 146. CLKOUT_CDIV_RATIO Register Address: 0x76

7	6	5	4	3	2	1	0
CDIV_PWR	CDIV_RTO[6:0]						
RW-0h	RW-1h						

LEGEND: R/W = Read/Write; R = Read only; -n = value after reset

Table 124. CLKOUT CDIV Ratio Field Descriptions

Bit	Field	Type	Reset	Description
7	CDIV_PWR	RW	0h	The CDIV divider is 0 = powered down 1 = powered up
6-0	CDIV_RTO[6:0]	RW	1h	The CDIV ratio is 0 = 128 1 = 1 2 = 2 ... 126 = 126 127 = 127

14.2.101 I2C_MISC (book=0x00 page=0x01 address=0x7C) [reset=0h]

Configures various I2C options

Figure 147. I2C_MISC Register Address: 0x7C

7	6	5	4	3	2	1	0
Reserved	I2C_HD	I2C_GCAE	Reserved				
RW-0h	RW-0h	RW-0h	RW-0h				

LEGEND: R/W = Read/Write; R = Read only; -n = value after reset

Table 125. I2C Misc Field Descriptions

Bit	Field	Type	Reset	Description
7	Reserved	RW	0h	Reserved
6	I2C_HD	RW	0h	I2C hang detecton. Read to clear. Do not write this bit high. I2C hang is 0 = detected 1 = not detected
5	I2C_GCAE	RW	0h	When enabled the part will respond to the configured I2C address as well as the general call I2C address. I2C general call address for multi-part loading is 0 = disabled 1 = enabled
4-0	Reserved	RW	0h	Reserved

14.2.102 DEVICE_ID (book=0x00 page=0x01 address=0x7D) [reset=12h]

Used to indicate device

Figure 148. DEVICE_ID Register Address: 0x7D

7	6	5	4	3	2	1	0
DEV_ID[7:0]							
R-12h							

LEGEND: R/W = Read/Write; R = Read only; -n = value after reset

Table 126. Device ID Field Descriptions

Bit	Field	Type	Reset	Description
7-0	DEV_ID[7:0]	R	12h	

14.2.103 PAGE (book=0x00 page=0x02 address=0x00) [reset=1h]

Selects the page for the next read or write.

Figure 149. PAGE Register Address: 0x00

7	6	5	4	3	2	1	0
PAGE[7:0]							
RW-1h							

LEGEND: R/W = Read/Write; R = Read only; -n = value after reset

Table 127. Page Select Field Descriptions

Bit	Field	Type	Reset	Description
7-0	PAGE[7:0]	RW	1h	Selects the Register Page for the next read or write command

14.2.104 RAMP_CTRL (book=0x00 page=0x02 address=0x06) [reset=0h]

Class-D Ramp Control

Figure 150. RAMP_CTRL Register Address: 0x06

7	6	5	4	3	2	1	0
Reserved		RAMP_FREQ[1:0]		Reserved		RAMP_FREQMOD[1:0]	
RW-0h		RW-0h		RW-0h		RW-0h	

LEGEND: R/W = Read/Write; R = Read only; -n = value after reset

Table 128. Class-D Ramp Control Field Descriptions

Bit	Field	Type	Reset	Description
7-6	Reserved	RW	0h	Reserved
5-4	RAMP_FREQ[1:0]	RW	0h	Rampgen frequency is 0 = 384kHz, use this for Fs of 48ksp/s and its multiples 1 = 352.8kHz, Use this for Fs of 44.1ksp/s and its multiples 2 = Reserved
3-2	Reserved	RW	0h	Reserved
1-0	RAMP_FREQMOD[1:0]	RW	0h	When SSM is enabled the ramp is modulated by 0 = Reserved 1 = +-5 % 2 = +-10 % 3 = Reserved

14.2.105 PROTECTION_CFG (book=0x00 page=0x02 address=0x09) [reset=3h]

Configures the Devices Protection Blocks

Figure 151. PROTECTION_CFG Register Address: 0x09

7	6	5	4	3	2	1	0
Reserved	Reserved	Reserved	Reserved	Reserved	OT_RT	Reserved	Reserved
RW-0h	RW-0h	RW-0h	RW-0h	RW-0h	RW-0h	RW-1h	RW-1h

LEGEND: R/W = Read/Write; R = Read only; -n = value after reset

Table 129. Configures the Devices Protection Blocks Field Descriptions

Bit	Field	Type	Reset	Description
7	Reserved	RW	0h	Reserved
6	Reserved	RW	0h	Reserved
5	Reserved	RW	0h	Reserved
4	Reserved	RW	0h	Reserved
3	Reserved	RW	0h	Reserved
2	OT_RT	RW	0h	Die over-temperature retry is 0 = Enabled 1 = Disabled
1	Reserved	RW	1h	Reserved
0	Reserved	RW	1h	Reserved

15 器件和文档支持

15.1 文档支持

15.2 社区资源

The following links connect to TI community resources. Linked contents are provided "AS IS" by the respective contributors. They do not constitute TI specifications and do not necessarily reflect TI's views; see TI's [Terms of Use](#).

TI E2E™ Online Community *TI's Engineer-to-Engineer (E2E) Community*. Created to foster collaboration among engineers. At e2e.ti.com, you can ask questions, share knowledge, explore ideas and help solve problems with fellow engineers.

Design Support *TI's Design Support* Quickly find helpful E2E forums along with design support tools and contact information for technical support.

15.3 商标

PurePath, E2E are trademarks of Texas Instruments.
All other trademarks are the property of their respective owners.

15.4 静电放电警告



这些装置包含有限的内置 ESD 保护。存储或装卸时，应将导线一起截短或将装置放置于导电泡棉中，以防止 MOS 门极遭受静电损伤。

15.5 Glossary

[SLYZ022](#) — *TI Glossary*.

This glossary lists and explains terms, acronyms, and definitions.

16 机械、封装和可订购信息

以下页中包括机械、封装和可订购信息。这些信息是针对指定器件可提供的最新数据。这些数据会在无通知且不对本文档进行修订的情况下发生改变。欲获得该数据表的浏览器版本，请查阅左侧的导航栏。

16.1 封装尺寸

TAS2557 采用 42 焊球、间距为 0.5mm 的 DSBGA 封装。

封装尺寸 (接下页)

TAS255xYZ, SN____255xYZ
YZ0042-C01

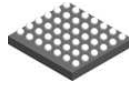

PACKAGE OUTLINE
DSBGA - 0.625 mm max height

DIE SIZE BALL GRID ARRAY

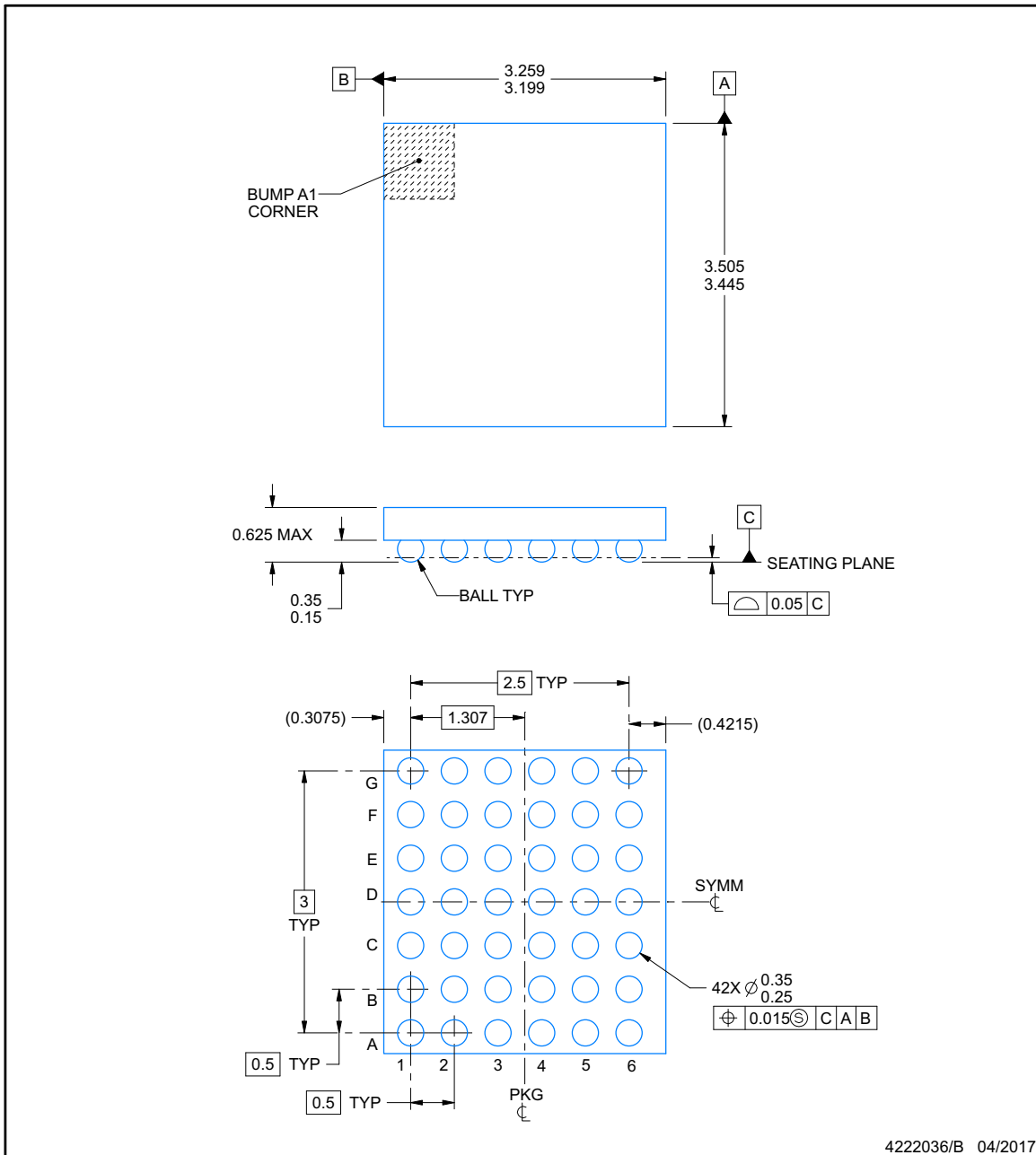

NOTES:

1. All linear dimensions are in millimeters. Any dimensions in parenthesis are for reference only. Dimensioning and tolerancing per ASME Y14.5M.
2. This drawing is subject to change without notice.

封装尺寸 (接下页)

TAS255xYZ, SN____255xYZ

EXAMPLE BOARD LAYOUT

YZ0042-C01

DSBGA - 0.625 mm max height

DIE SIZE BALL GRID ARRAY

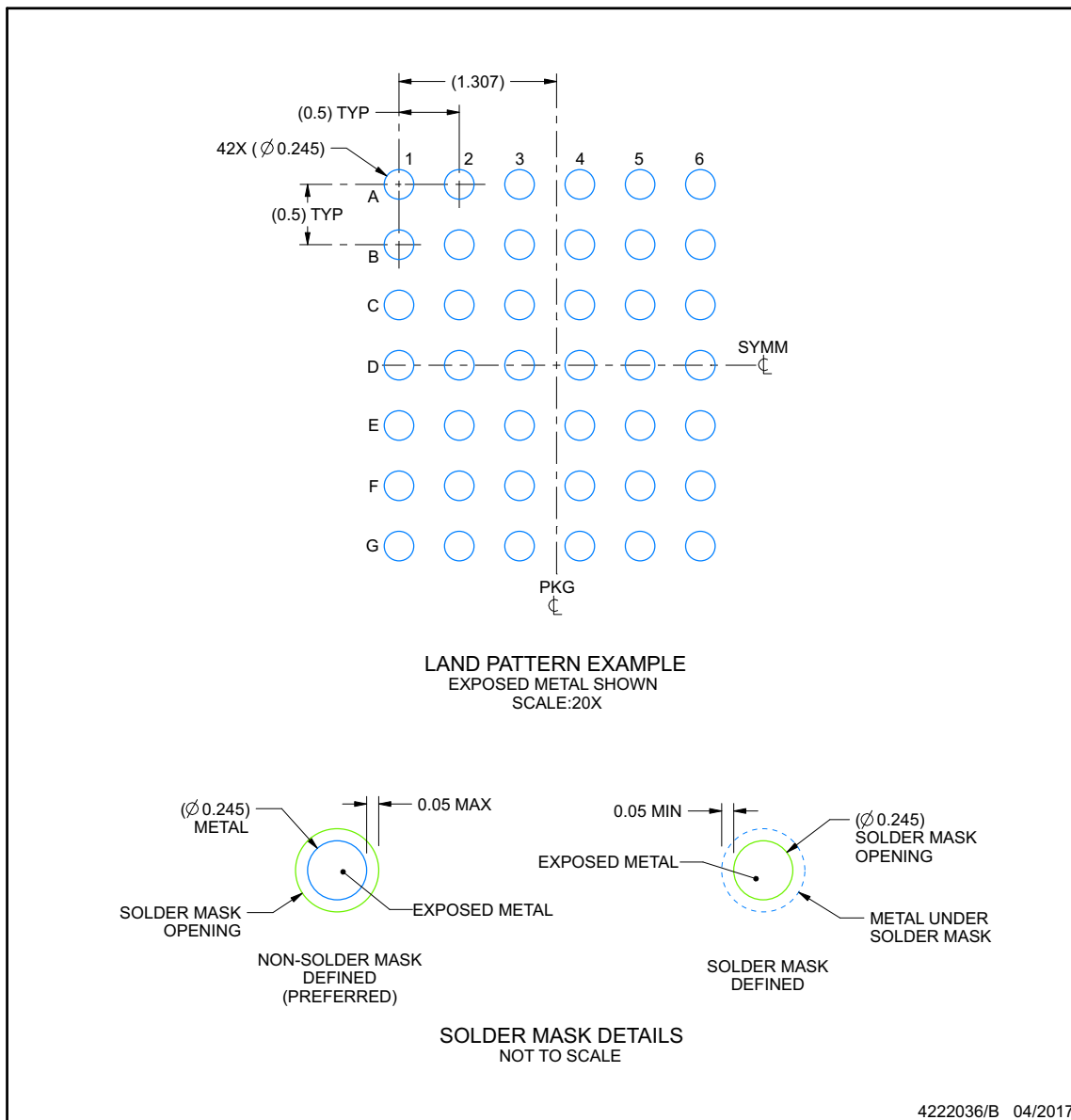

NOTES: (continued)

- Final dimensions may vary due to manufacturing tolerance considerations and also routing constraints. For more information, see Texas Instruments literature number SNVA009 (www.ti.com/lit/snva009).

封装尺寸 (接下页)

TAS255xYZ, SN____255xYZ

EXAMPLE STENCIL DESIGN

YZ0042-C01

DSBGA - 0.625 mm max height

DIE SIZE BALL GRID ARRAY

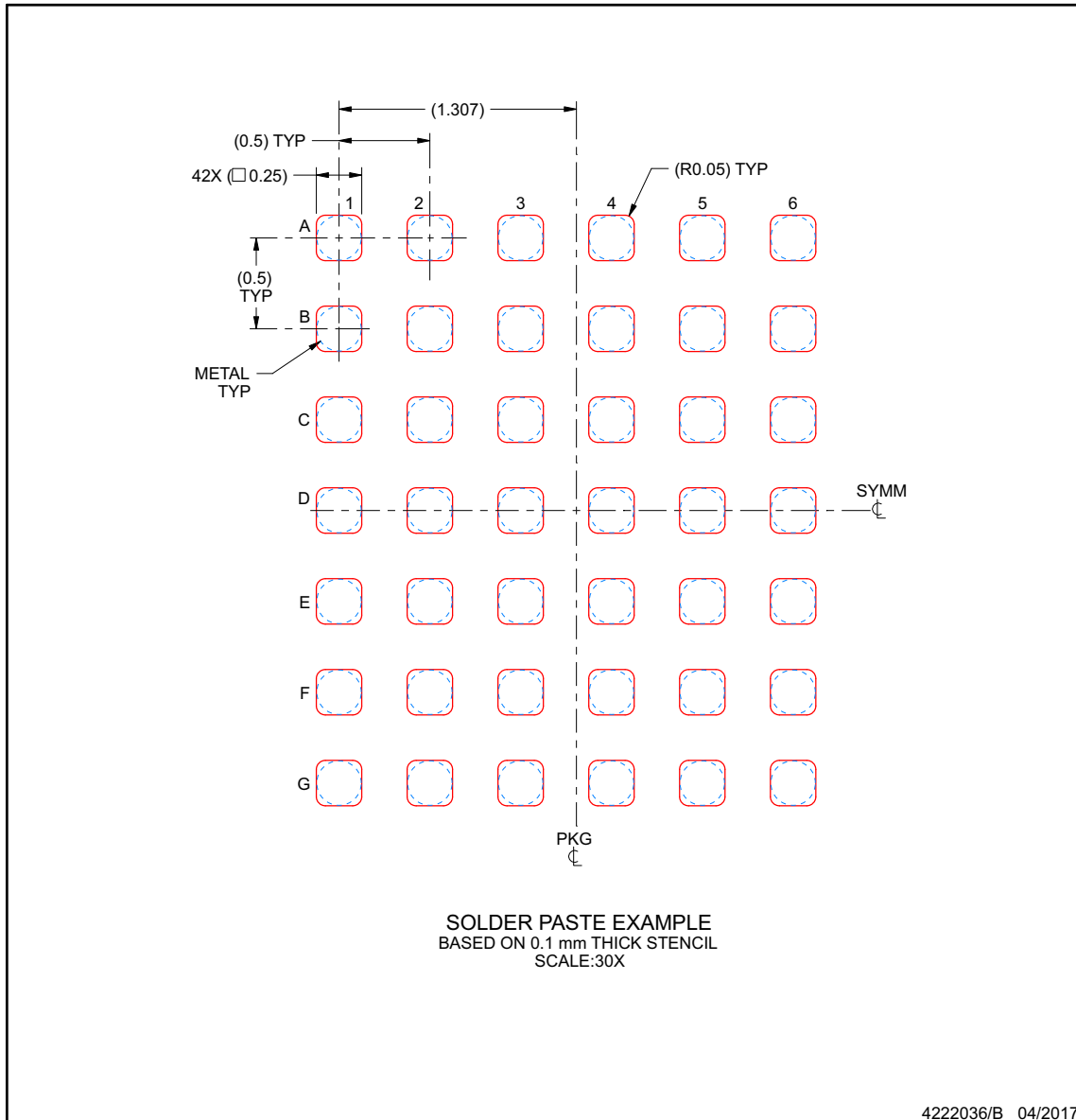

NOTES: (continued)

- 4. Laser cutting apertures with trapezoidal walls and rounded corners may offer better paste release.

PACKAGING INFORMATION

Orderable Device	Status (1)	Package Type	Package Drawing	Pins	Package Qty	Eco Plan (2)	Lead/Ball Finish (6)	MSL Peak Temp (3)	Op Temp (°C)	Device Marking (4/5)	Samples
TAS2557YZR	ACTIVE	DSBGA	YZ	42	3000	Green (RoHS & no Sb/Br)	SNAGCU	Level-1-260C-UNLIM	-40 to 85	2557	Samples
TAS2557YZT	ACTIVE	DSBGA	YZ	42	250	Green (RoHS & no Sb/Br)	SNAGCU	Level-1-260C-UNLIM	-40 to 85	2557	Samples

(1) The marketing status values are defined as follows:

ACTIVE: Product device recommended for new designs.

LIFEBUY: TI has announced that the device will be discontinued, and a lifetime-buy period is in effect.

NRND: Not recommended for new designs. Device is in production to support existing customers, but TI does not recommend using this part in a new design.

PREVIEW: Device has been announced but is not in production. Samples may or may not be available.

OBSELETE: TI has discontinued the production of the device.

(2) Eco Plan - The planned eco-friendly classification: Pb-Free (RoHS), Pb-Free (RoHS Exempt), or Green (RoHS & no Sb/Br) - please check <http://www.ti.com/productcontent> for the latest availability information and additional product content details.

TBD: The Pb-Free/Green conversion plan has not been defined.

Pb-Free (RoHS): TI's terms "Lead-Free" or "Pb-Free" mean semiconductor products that are compatible with the current RoHS requirements for all 6 substances, including the requirement that lead not exceed 0.1% by weight in homogeneous materials. Where designed to be soldered at high temperatures, TI Pb-Free products are suitable for use in specified lead-free processes.

Pb-Free (RoHS Exempt): This component has a RoHS exemption for either 1) lead-based flip-chip solder bumps used between the die and package, or 2) lead-based die adhesive used between the die and leadframe. The component is otherwise considered Pb-Free (RoHS compatible) as defined above.

Green (RoHS & no Sb/Br): TI defines "Green" to mean Pb-Free (RoHS compatible), and free of Bromine (Br) and Antimony (Sb) based flame retardants (Br or Sb do not exceed 0.1% by weight in homogeneous material)

(3) MSL, Peak Temp. - The Moisture Sensitivity Level rating according to the JEDEC industry standard classifications, and peak solder temperature.

(4) There may be additional marking, which relates to the logo, the lot trace code information, or the environmental category on the device.

(5) Multiple Device Markings will be inside parentheses. Only one Device Marking contained in parentheses and separated by a "~" will appear on a device. If a line is indented then it is a continuation of the previous line and the two combined represent the entire Device Marking for that device.

(6) Lead/Ball Finish - Orderable Devices may have multiple material finish options. Finish options are separated by a vertical ruled line. Lead/Ball Finish values may wrap to two lines if the finish value exceeds the maximum column width.

Important Information and Disclaimer: The information provided on this page represents TI's knowledge and belief as of the date that it is provided. TI bases its knowledge and belief on information provided by third parties, and makes no representation or warranty as to the accuracy of such information. Efforts are underway to better integrate information from third parties. TI has taken and continues to take reasonable steps to provide representative and accurate information but may not have conducted destructive testing or chemical analysis on incoming materials and chemicals. TI and TI suppliers consider certain information to be proprietary, and thus CAS numbers and other limited information may not be available for release.

In no event shall TI's liability arising out of such information exceed the total purchase price of the TI part(s) at issue in this document sold by TI to Customer on an annual basis.

TAPE AND REEL INFORMATION



QUADRANT ASSIGNMENTS FOR PIN 1 ORIENTATION IN TAPE



*All dimensions are nominal

Device	Package Type	Package Drawing	Pins	SPQ	Reel Diameter (mm)	Reel Width W1 (mm)	A0 (mm)	B0 (mm)	K0 (mm)	P1 (mm)	W (mm)	Pin1 Quadrant
TAS2557YZR	DSBGA	YZ	42	3000	330.0	12.4	3.4	3.75	0.82	8.0	12.0	Q1
TAS2557YZT	DSBGA	YZ	42	250	330.0	12.4	3.4	3.75	0.82	8.0	12.0	Q1

TAPE AND REEL BOX DIMENSIONS

*All dimensions are nominal

Device	Package Type	Package Drawing	Pins	SPQ	Length (mm)	Width (mm)	Height (mm)
TAS2557YZR	DSBGA	YZ	42	3000	367.0	367.0	35.0
TAS2557YZT	DSBGA	YZ	42	250	367.0	367.0	35.0

重要声明

德州仪器 (TI) 公司有权按照最新发布的 JESD46 对其半导体产品和服务进行纠正、增强、改进和其他修改，并不再按最新发布的 JESD48 提供任何产品和服务。买方在下订单前应获取最新的相关信息，并验证这些信息是否完整且是最新的。

TI 公布的半导体产品销售条款 (<http://www.ti.com/sc/docs/stdterms.htm>) 适用于 TI 已认证和批准上市的已封装集成电路产品的销售。另有其他条款可能适用于其他类型 TI 产品及服务的使用或销售。

复制 TI 数据表上 TI 信息的重要部分时，不得变更该等信息，且必须随附所有相关保证、条件、限制和通知，否则不得复制。TI 对该等复制文件不承担任何责任。第三方信息可能受到其它限制条件的制约。在转售 TI 产品或服务时，如果存在对产品或服务参数的虚假陈述，则会失去相关 TI 产品或服务的明示或暗示保证，且构成不公平的、欺诈性商业行为。TI 对此类虚假陈述不承担任何责任。

买方和在系统中整合 TI 产品的其他开发人员（总称“设计人员”）理解并同意，设计人员在设计应用时应自行实施独立的分析、评价和判断，且应全权负责并确保应用的安全性，及设计人员的应用（包括应用中使用的 TI 产品）应符合所有适用的法律法规及其他相关要求。设计人员就自己设计的应用声明，其具备制订和实施下列保障措施所需的一切必要专业知识，能够 (1) 预见故障的危险后果，(2) 监视故障及其后果，以及 (3) 降低可能导致危险的故障几率并采取适当措施。设计人员同意，在使用或分发包含 TI 产品的任何应用前，将彻底测试该等应用和该等应用中所用 TI 产品的功能。

TI 提供技术、应用或其他设计建议、质量特点、可靠性数据或其他服务或信息，包括但不限于与评估模块有关的参考设计和材料（总称“TI 资源”），旨在帮助设计人员开发整合了 TI 产品的应用，如果设计人员（个人，或如果是代表公司，则为设计人员的公司）以任何方式下载、访问或使用任何特定的 TI 资源，即表示其同意仅为该等目标，按照本通知的条款使用任何特定 TI 资源。

TI 所提供的 TI 资源，并未扩大或以其他方式修改 TI 对 TI 产品的公开适用的质保及质保免责声明；也未导致 TI 承担任何额外的义务或责任。TI 有权对其 TI 资源进行纠正、增强、改进和其他修改。除特定 TI 资源的公开文档中明确列出的测试外，TI 未进行任何其他测试。

设计人员只有在开发包含该等 TI 资源所列 TI 产品的应用时，才被授权使用、复制和修改任何相关 TI 资源。但并未依据禁止反言原则或其他法律授予您任何 TI 知识产权的任何其他明示或默示的许可，也未授予您 TI 或第三方的任何技术或知识产权的许可，该等许可包括但不限于任何专利权、版权、屏蔽作品权或与美国 TI 产品或服务的任何整合、机器制作、流程相关的其他知识产权。涉及或参考了第三方产品或服务的信息不构成使用此类产品或服务的许可或与其相关的保证或认可。使用 TI 资源可能需要您向第三方获得对该等第三方专利或其他知识产权的许可。

TI 资源系“按原样”提供。TI 兹免除对资源及其使用作出所有其他明确或默示的保证或陈述，包括但不限于对准确性或完整性、产权保证、无屡发故障保证，以及适销性、适合特定用途和不侵犯任何第三方知识产权的任何默认保证。TI 不负责任何申索，包括但不限于因组合产品所致或与之有关的申索，也不为或对设计人员进行辩护或赔偿，即使该等产品组合已列于 TI 资源或其他地方。对因 TI 资源或其使用引起或与之有关的任何实际的、直接的、特殊的、附带的、间接的、惩罚性的、偶发的、从属或惩戒性损害赔偿，不管 TI 是否获悉可能会产生上述损害赔偿，TI 概不负责。

除 TI 已明确指出特定产品已达到特定行业标准（例如 ISO/TS 16949 和 ISO 26262）的要求外，TI 不对未达到任何该等行业标准要求而承担任何责任。

如果 TI 明确宣称产品有助于功能安全或符合行业功能安全标准，则该等产品旨在帮助客户设计和创作自己的符合相关功能安全标准和要求的的应用。在应用内使用产品的行为本身不会配有安全特性。设计人员必须确保遵守适用于其应用的相关安全要求和标准。设计人员不可将任何 TI 产品用于关乎性命的医疗设备，除非已由各方获得授权的管理人员签署专门的合同对此类应用专门作出规定。关乎性命的医疗设备是指出现故障会导致严重身体伤害或死亡的医疗设备（例如生命保障设备、心脏起搏器、心脏除颤器、人工心脏泵、神经刺激器以及植入设备）。此类设备包括但不限于，美国食品药品监督管理局认定为 III 类设备的设备，以及在美国以外的其他国家或地区认定为同等类别设备的所有医疗设备。

TI 可能明确指定某些产品具备某些特定资格（例如 Q100、军用级或增强型产品）。设计人员同意，其具备一切必要专业知识，可以为自己的应用选择适合的产品，并且正确选择产品的风险由设计人员承担。设计人员单方面负责遵守与该等选择有关的所有法律或监管要求。

设计人员同意向 TI 及其代表全额赔偿因其不遵守本通知条款和条件而引起的任何损害、费用、损失和/或责任。

邮寄地址：上海市浦东新区世纪大道 1568 号中建大厦 32 楼，邮政编码：200122
Copyright © 2017 德州仪器半导体技术（上海）有限公司