

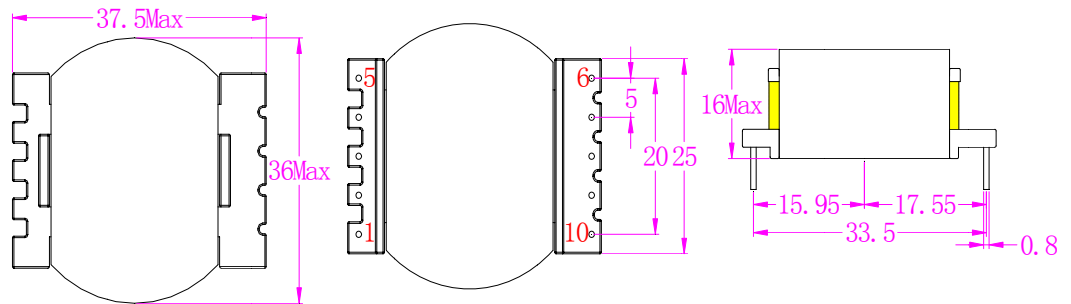

Shenzhen Pinho Technology Co.Ltd.

Product type:High frequency Transformer Type:POT3314

◆ **Dimensions (mm)**

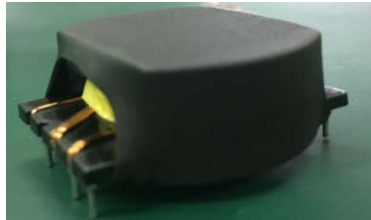

◆ **Schematic diagram**

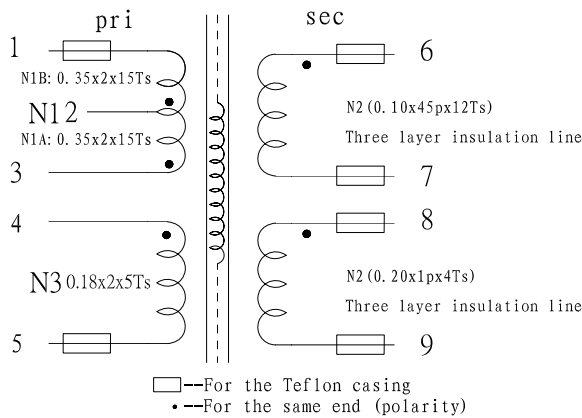

Magnetic core characteristics

Magnetic core material PC44
 Core Ae=144.2mm²
 Core Le=41.6mm
 Core Ve=6009.6mm³
 Core ui= 2400 ± 25%
 CoreAL=6800 ± 25%
 Core Bs=25°C/510 100°C/390 mT

◆ **Characteristic description**

- a、PRI(3-1pin)INDUCTORS:500uH
- b、Turns:30:12:5:4Ts
- c、HI-POT Test PRI CORE-SEC:3750VAC/3mA/60s
- d、Measured frequency of inductance is 10 KHz/0.25V
- e、Working frequency is recommended 60KHz ref
- f、Transformer AC-DC output power recommended at 70W

◆ **Product Description**

- a、Magnetic shielding structure, Excellent resistanceto electromagnetic interference.
- b、Dimensions 37.0×36.0×16.0mm.

c、 In addition to the standards versions shown here,custom transformer are also available to meet your exact requirements

◆ **Feature& Application**

- a、 Mn-Zn core used, Flat wire used.
- b、 LED drive power supply and power adapter.
- c、 RoHS Compliance and Halogen free.



◆ **Environmental Data**

- a、 Operating temperature range: $-40^{\circ}\text{C} \sim +125^{\circ}\text{C}$ (including coil's self temperature rise).
- b、 Storage temperature range: $-40^{\circ}\text{C} \sim +100^{\circ}\text{C}$.