



DP2357 2A,25V,DC/DC Step-Down Converter

Description

The DP2357 is a monolithic step-down switch mode converter with a built in internal power MOSFET. It achieves 2A continuous output current over a wide input supply range with excellent load and line regulation.

The DP2357 requires a minimum number of readily available standard external components. Current mode operation provides fast transient response and eases loop stabilization.

Fault condition protection includes cycle-by-cycle current limiting and thermal shutdown. In shutdown mode the regulator draws 25µA of supply current.

Features

- 2A Output Current
- 0.22Ω Internal Power MOSFET Switch
- Stable with Low ESR Output Ceramic Capacitors
- Up to 95% Efficiency
- 25µA Shutdown Mode
- Fixed 450KHz Frequency
- Thermal Shutdown
- Cycle-by-Cycle Over Current Protection
- Wide 4.75 to 25V Operating Input Range
- Output Adjustable from 1.22V to 21V
- Programmable Under Voltage Lockout

Applications

- Distributed Power Systems
- Battery Chargers
- Pre-Regulator for Linear Regulators
- PC Monitors

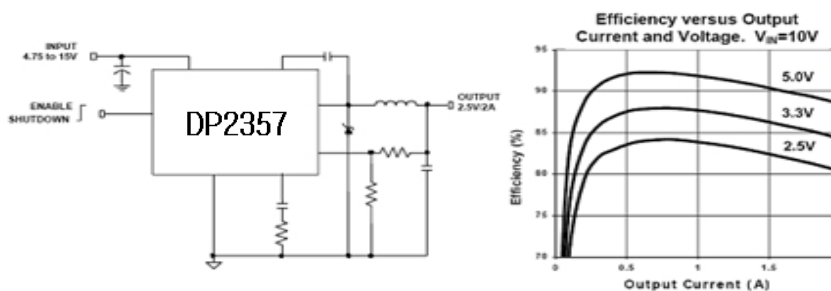

Package Reference

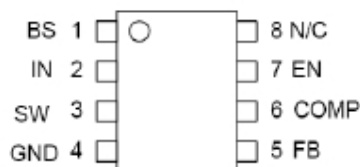

Part number	Package	Temperature
DP2357S	SOIC8	-40 C to +125 C
DP2357P	PDIP8	-40 C to +125 C



Absolute Maximum Ratings

Supply Voltage (VIN)...27V
Switch Voltage (VSW)...-1V to VIN + 1V
Bootstrap Voltage (VBS)...Vsw-0.3V to VSW + 6V
Enable/UVLO Voltage (VEN)...-0.3V to +6V
Comp Voltage (VCOMP)...-0.3V to +6V
Feedback Voltage (VFB)...-0.3V to +6V
Junction Temperature...+150°C
Lead Temperature...+260°C
Storage Temperature...-65°C to +150°C

Recommended Operating Conditions

Input Voltage (VIN)4.75V to 25V
Operating Temperature-40°C to +125°C

Thermal Resistance(3) θJA θJC

SOIC8105..... 50... °C/W
PDIP895.....55.. °C/W

Notes:

- 1) Exceeding these ratings may damage the device.
2) The device is not guaranteed to function outside of its operating conditions.
3) Measured on approximately 1" square of 1 oz copp.

Electrical Characteristics VIN = 12V, VEN = 5V,TA = +25°C, unless unless otherwise noted.

Table with 6 columns: Parameter, Condition, Min, Typ, Max, Units. Rows include Feedback Voltage, Upper Switch-On Resistance, Lower Switch-On Resistance, Upper Switch Leakage, Current Limit, Oscillator Frequency, Short Circuit Frequency, Maximum Duty Cycle, Minimum Duty Cycle, EN Shutdown Threshold Voltage, EN UVLO Threshold Rising, EN UVLO Threshold Hysteresis, Enable Pull-Up Current, Supply Current (Shutdown), Supply Current (Quiescent), Thermal Shutdown.



DP2357

2A,25V,DC/DC Step-Down Converter

Pin Function

Pin #	Name	Description
1	BS	High-Side Gate Drive Boost Input. BS supplies the drive for the high-side N-channel MOSFET switch. Connect a 10nF or greater capacitor from SW to BS to power the switch.
2	IN	Power Input. IN supplies the power to the IC, as well as the step-down converter switch. Drive IN with a 4.75 to 25V power source. Bypass IN to GND with a suitably large capacitor to eliminate noise on the input to the IC. <i>See Input Capacitor.</i>
3	SW	Power Switching Output. SW is the switching node that supplies power to the output. Connect the output LC filter from SW to the output load. Note that a capacitor is required from SW to BS to power the high-side switch.
4	GND	Ground.
5	FB	Feedback Input. FB senses the output voltage to regulate that voltage. Drive FB with resistive voltage divider from the output voltage. The feedback threshold is 1.222V. <i>Setting the Output Voltage.</i>
6	COMP	Compensation Node. COMP is used to compensate the regulation control loop. Connect a series RC network from COMP to GND to compensate the regulation control loop. <i>See Compensation.</i>
7	EN	Enable Input. EN is a digital input that turns the regulator on or off. Drive EN high to turn on the regulator, low to turn it off. For automatic startup, leave EN unconnected.
8	NC	No Connect.

Operation

The DP2357 is a current-mode step-downswitch-mode regulator. It regulates input voltages from 4.75V to 25V down to an output voltage as low as 1.222V and is able to supply up to 2A of load current. The DP2357 uses current-mode control to regulate the output voltage. The output voltage is measured at FB through a resistive voltage divider and amplified through the internal error amplifier. The output current of the transconductance error amplifier is presented at COMP where a network compensates the regulation control system. The voltage at COMP is compared to the switch current measured internally to control the output voltage. The converter uses an internal N-Channel MOSFET switch to step down the input voltage

to the regulated output voltage. Since the MOSFET requires a gate voltage greater than the input voltage, a boost capacitor connected between SW and BS drives the gate. The capacitor is internally charged while the switch is off. An internal 10 Ω switch from SW to GND is used to ensure that SW is pulled to GND when the switch is off to fully charge the BS capacitor

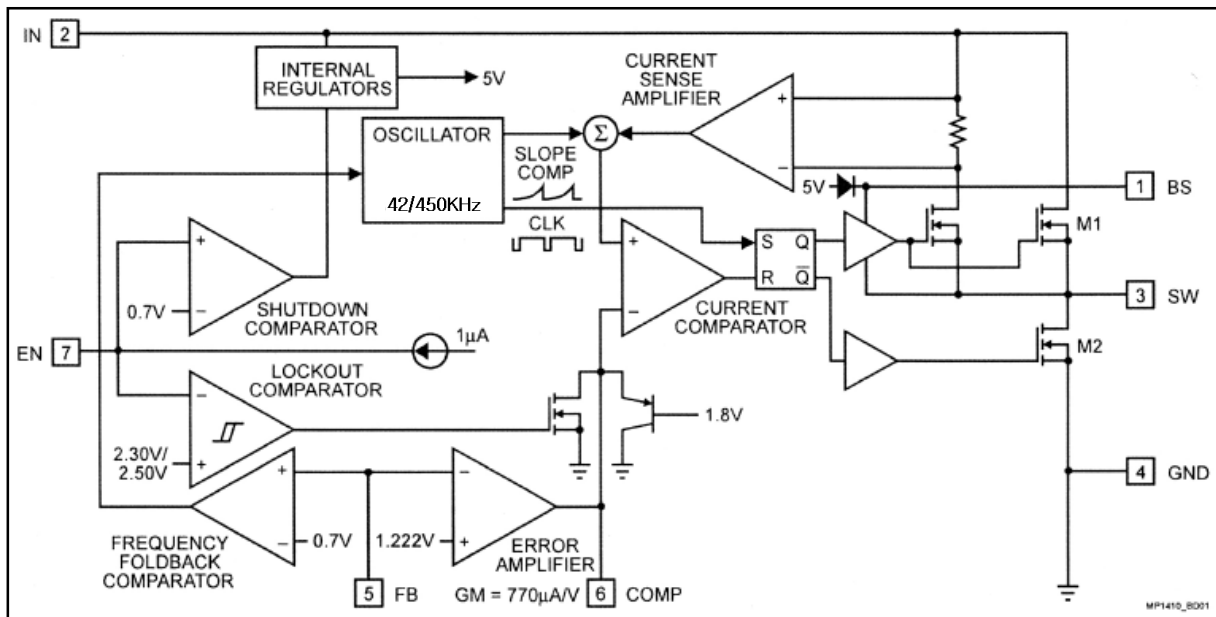

Figure 1 – Functional Block Diagram

Application Information Component Selection Setting the Output Voltage

The output voltage is set using a resistive voltage divider from the output voltage to FB (see Typical Application circuit on page 1). The voltage divider divides the output voltage down by the ratio:

$$V_{FB} = V_{OUT} \frac{R2}{R1 + R2}$$

Where VFB is the feedback voltage and VOUT is the output voltage. Thus the output voltage is:

$$V_{OUT} = 1.222 \times \frac{R1 + R2}{R2}$$

R2 can be as high as 100kΩ, but a typical value is 10kΩ. Using that value, R1 is determined by:

$$R1 \cong 8.18 \times (V_{OUT} - 1.222)$$

For example, for a 3.3V output voltage, R2 is 10kΩ, and R1 is 16.9kΩ.

Inductor

The inductor is required to supply constant current to the output load while being driven by the switched input voltage. A larger value inductor results in less ripple current that results in lower output ripple voltage. However, the larger value inductor has a larger physical size, higher series resistance and/or lower saturation current. Choose an inductor that does not saturate under the worst-case load conditions. A good rule for determining the inductance is to allow the peak-to-peak ripple current in the inductor to be approximately 30% of the maximum load current. Also, make sure that the peak inductor current (the load current plus half the peak-to-peak inductor ripple current) is below the 2.4A minimum current limit. The inductance value can be calculated by the equation:

$$L = V_{OUT} \times \frac{(V_{IN} - V_{OUT})}{V_{IN} \times f \times \Delta I}$$



Where VIN is the input voltage, f is the switching frequency, and ΔI is the peak-to-peak inductor ripple current.

Table 1 lists a number of suitable inductors from various manufacturers.

Table 1—Inductor Selection Guide

Vendor/ Model	Core Type	Core Ma-terial	Package Dimensions (mm)		
			W	L	H
Sumida					
CR75	Open	Ferrite	7.0	7.8	5.5
CDH74	Open	Ferrite	7.3	8.0	5.2
CDRH5D28	Shielded	Ferrite	5.5	5.7	5.5
CDRH5D28	Shielded	Ferrite	5.5	5.7	5.5
CDRH6D28	Shielded	Ferrite	6.7	6.7	3.0
CDRH104R	Shielded	Ferrite	10.1	10.0	3.0
Toko					
D53LC Type A	Shielded	Ferrite	5.0	5.0	3.0
D75C	Shielded	Ferrite	7.6	7.6	5.1
D104C	Shielded	Ferrite	10.0	10.0	4.3
D10FL	Open	Ferrite	9.7	1.5	4.0
Coilcraft					
DO3308	Open	Ferrite	9.4	13.0	3.0
D03316	Open	Ferrite	9.4	13.0	5.1

Input Capacitor

The input current to the step-down converter is discontinuous, and therefore an input capacitor C1 is required to supply the AC current to the step-down converter while maintaining the DC input voltage. A low ESR capacitor is required to keep the noise at the IC to a minimum. Ceramic capacitors are preferred, but tantalum or low-ESR electrolytic capacitors may also suffice. The input capacitor value should be greater than 10uF. The capacitor can be electrolytic, tantalum or ceramic. However, since it absorbs the input switching current it requires an adequate ripple current rating. Its RMS current rating should be greater than approximately 1/2 of the DC load current. For insuring stable operation, C2 should be placed as close to the IC as possible. Alternately a smaller high quality ceramic 0.1 uF capacitor may be placed closer to the IC and a larger capacitor placed further away. If using this technique, it is recommended that the larger capacitor be a tantalum or electrolytic type. All ceramic capacitors should be placed close to the DP2357.

Output Capacitor

The output capacitor is required to maintain the DC output voltage. Low ESR capacitors are preferred to keep the output voltage ripple low. The characteristics of the output capacitor also affect the stability of the regulation control system. Ceramic, tantalum or low ESR electrolytic capacitors are recommended. In the case of ceramic capacitors, the impedance at the switching frequency is dominated by the capacitance and so the output voltage ripple is mostly independent of the ESR. The output voltage ripple is estimated to be:



$$V_{\text{RIPPLE}} \cong 1.4 \times V_{\text{IN}} \times \left(\frac{f_{\text{LC}}}{f} \right)^2$$

In the case of tantalum or low-ESR electrolytic capacitors, the ESR dominates the impedance at the switching frequency, and so the output ripple is calculated as

$$V_{\text{RIPPLE}} \cong \Delta I \times R_{\text{ESR}}$$

Output Rectifier Diode

The output rectifier diode supplies the current to the inductor when the high-side switch is off. To reduce losses due to the diode forward voltage and recovery times, use a Schottky rectifier. Table 2 provides the Schottky rectifier part numbers. Choose a rectifier the maximum reverse voltage rating of which is greater than the maximum input voltage, and has a current rating greater than the maximum load current.

Compensation

The system stability is controlled through the COMP pin. COMP is the output of the internal transconductance error amplifier. A series capacitor-resistor combination sets a pole-zero combination to control the characteristics of the control system.

The DC loop gain is:

$$A_{\text{VDC}} = R_{\text{LOAD}} \times G_{\text{CS}} \times A_{\text{VEA}} \times \frac{V_{\text{FB}}}{V_{\text{OUT}}}$$

Where AVEA is the transconductance error amplifier voltage gain (400V/V), Gcs is the current sense gain (roughly the output current divided by the voltage at COMP) equal to 1.95 A/V and RLOAD is the load resistance (VOUT / IOUT where IOUT is the output load current). The system has two poles of importance, one is due to the compensation capacitor (C3), and the other is due to the output capacitor (C2). These are: used on the maximum input voltage and current rating.

Table 2—Schottky Rectifier Selection Guide

VIN (Max)	2A Load Current	
	Part Number	Vendor
15V	30BQ015	4
20V	B220	1
	SK23	6
	SR22	6
26V	20BQ030	4
	B230	1
	SK23	6
	SR23	3,6

Table 3 lists some rectifier manufacturers.

Table 3—Schottky Diode Manufacture



Vendor	Web Site
Diodes, Inc.	www.diodes.com
Fairchild Semiconductor	www.fairchildsemi.com
General Semiconductor	www.gensemi.com
International Rectifier	www.irf.com
On Semiconductor	www.onsemi.com
Pan Jit International	www.panjit.com.tw

$$f_{P1} = \frac{G_{EA}}{2\pi \times C3 \times A_{VEA}}$$

Where P1 is the first pole and GEA is the error amplifier transconductance (770uA/V). The other pole is:

$$f_{P2} = \frac{1}{2\pi \times C2 \times R_{LOAD}}$$

The system has one zero of importance, due to the compensation capacitor (C3) and the compensation resistor (R3). The zero is:

$$f_{Z1} = \frac{1}{2\pi \times C3 \times R3}$$

If a large value capacitor (C2) with relatively high equivalent-series-resistance (ESR) is used, the zero due to the capacitance and ESR of the output capacitor can be compensated by a third pole set by R3 and C6:

$$f_{P3} = \frac{1}{2\pi \times C6 \times R3}$$

The system crossover frequency (the frequency where the loop gain drops to 1 or 0dB) is important. A good rule of thumb is to set the crossover frequency to approximately 1/10 of the switching frequency. In this case, the switching frequency is 450KHz. Therefore, use a crossover frequency (fc) of 40KHz. Lower crossover frequencies result in

Choosing the Compensation Components

The values of the compensation components given in Table 4 yield a stable control loop for the output voltage and capacitor given.

Table 4—Compensation Values for Typical Output Voltage/Capacitor Combinations

2.5V	560uF/6.3V (30mΩ ESR)	200kΩ	1nF	100pF
3.3V	560uF/6.3V (30mΩ ESR)	200kΩ	1nF	82pF
5V	470uF/10V (30mΩ ESR)	250kΩ	1nF	56pF
12V	220uF/25V (30mΩ ESR)	250kΩ	1nF	27pF



DP2357 2A,25V,DC/DC Step-Down Converter

To optimize the compensation components for conditions not listed in Table 4, use the following procedure:

Choose the compensation resistor to set the desired crossover frequency. Determine the value by the following equation:

$$R3 = \frac{2\pi \times C2 \times f_C}{G_{EA} \times G_{CS}} \times \frac{V_{OUT}}{V_{FB}}$$

Putting in the know constants and setting the crossover frequency to the desired 40KHz:

$$R3 \approx 1.37 \times 10^8 \times C2 \times V_{OUT}$$

Choose the compensation capacitor to set the zero below 1/4 of the crossover frequency. Determine the value by the following equation:

$$C3 > \frac{0.22 \times C2 \times V_{OUT}}{R3}$$

Determine if the second compensation capacitor, C6, is required. It is required if the ESR zero of the output capacitor occurs at less than four times the crossover frequency.

$$8\pi \times C2 \times R_{ESR} \times f_C \geq 1$$

Or

$$\frac{7.34 \times 10^{-5} \times R3 \times R_{ESR}}{V_{OUT}} \geq 1$$

slower response and worse transient load recovery. Higher crossover frequencies can result in instability.

If this is the case, add the second compensation capacitor. Determine the value by the equation:

$$C6 = \frac{C2 \times R_{ESR(MAX)}}{R3}$$

Where RESR(MAX) is the maximum equivalent series resistance of the output capacitor

For Example:

VQUT = 3.3V

C2 = 22uFCeramic(ESR = 10mΩ)

R3 ≈ (1.37 × 10⁸) × (22 × 10⁻⁶) × 3.3 = 9.9kΩ

Use the nearest standard value of 10kΩ

C3 > (0.22 × (22 × 10⁻⁶) × 3.3) / (10 × 10³) = 1.6nF

Use a standard value of 2nF.

2π × C2 × RESR × fC = 0.014

which is less than 1, therefore no second compensation capacitor is required.



DP2357 2A,25V,DC/DC Step-Down Converter

Table 5 – Recommended Components for Standard

Output Voltage

VOUT	R1	L1 Minimum
1.22V	0 Ω	6.8uH
1.5V	2.32 k Ω	6.8uH
1.8V	4.75 k Ω	10uH
2.5V	10.5 k Ω	10uH
3.3V	16.9 k Ω	15uH
5.0V	30.9 k Ω	22uH

Negative Output Voltage

The DP2357 can be configured as a buck-boost regulator to supply negative output voltage. Because the GND pin of the IC is now connected to negative output voltage, the maximum allowable input voltage is the IC input voltage rating (25V) minus the negative output voltage value. A typical application circuit is shown in Figure 3.

External Bootstrap Diode

It is recommended that an external bootstrap diode be added when the system has a 5V fixed input or the power supply generates a 5V output. This helps improve the efficiency of the regulator. The bootstrap diode can be a low cost one such as IN4148 or BAT54.

This diode is also recommended for high duty cycle operation (when $(V_{OUT}/V_{IN}) > 65\%$) and high output

voltage ($V_{OUT} > 12V$) applications

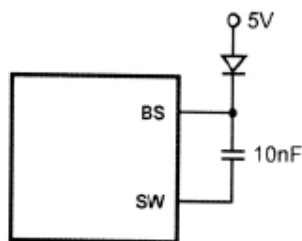

Figure 2 - External Bootstrap Diode

Typical Application Circuits



DP2357

2A,25V,DC/DC Step-Down Converter

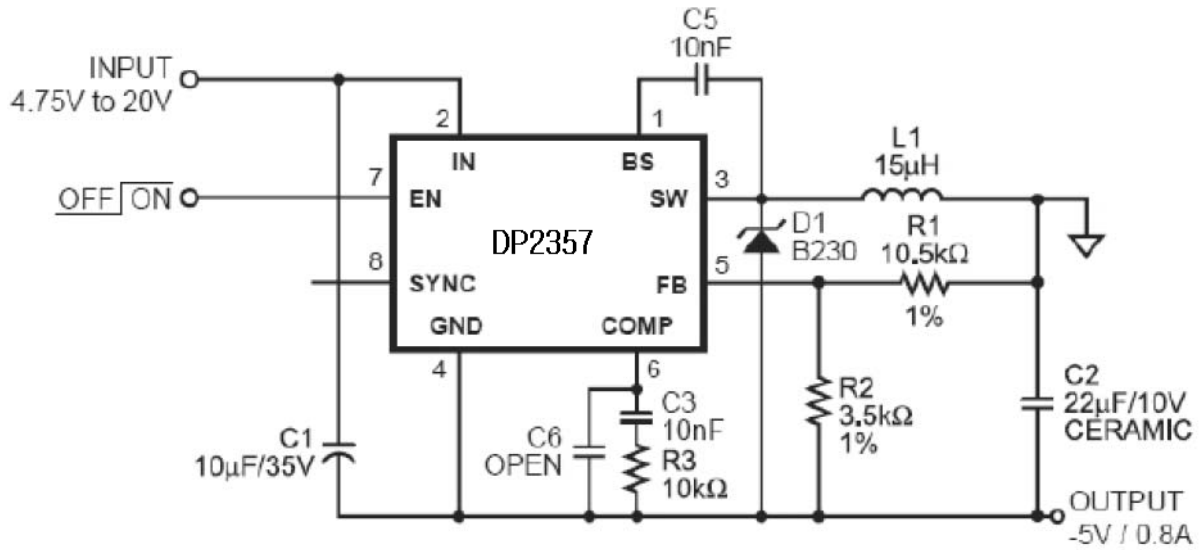
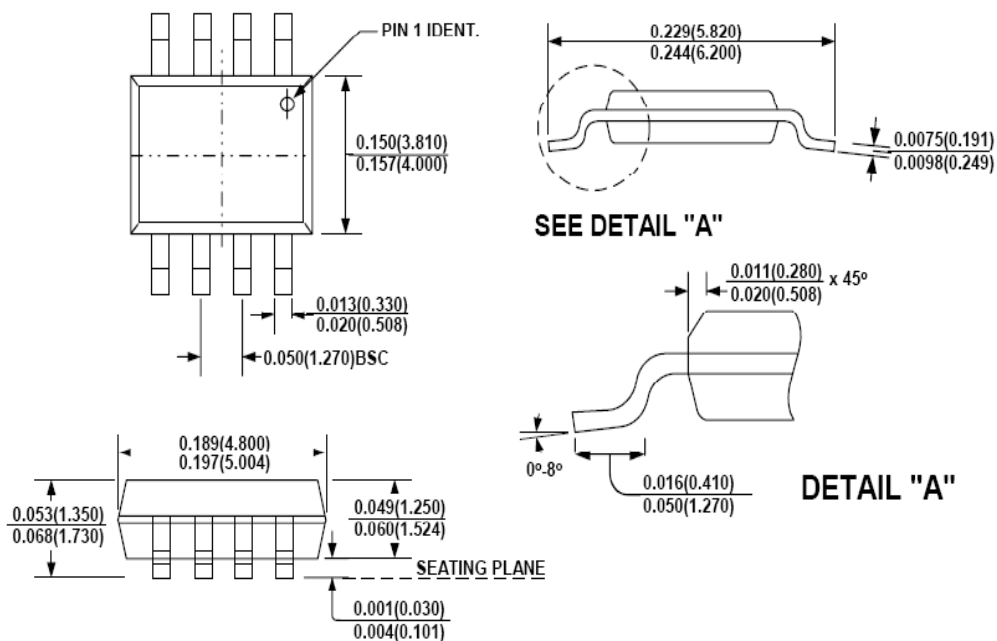

Figure 3—Application Circuit for -5V Supply

Package Information

SOIC8



NOTE:
 1) Control dimension is in inches. Dimension in bracket is millimeters.



DP2357 2A,25V,DC/DC Step-Down Converter

PDIP8

