

### GENERAL DESCRIPTION

OB2283 is a highly integrated current mode PWM control IC optimized for high performance, low standby power and cost effective offline flyback converter applications.

PWM switching frequency at normal operation is internally fixed and is trimmed to tight range. At no load or light load condition, the IC operates in extended 'burst mode' to minimize switching loss. Lower standby power and higher conversion efficiency is thus achieved.

VCC low startup current and low operating current contribute to a reliable power on startup and low standby design with OB2283.

OB2283 offers comprehensive protection coverage with auto-recovery including Cycle-by-Cycle current limiting (OCP), over load protection (OLP), and VCC under voltage lockout (UVLO). It also provides the protections with latched shut down including over temperature protection (OTP), and over voltage protection (OVP). Excellent EMI performance is achieved with On-Bright proprietary frequency shuffling technique.

The tone energy at below 25KHz is minimized in the design and audio noise is eliminated during operation.

OB2283 is offered in SOT23-6 package.

### APPLICATIONS

Offline AC/DC flyback converter for

- Printer, Storage power supply
- Power Adapter

### FEATURES

- Power on soft start reducing MOSFET Vds stress
- Frequency shuffling for EMI
- Extended burst mode control for improved efficiency and low standby power design
- Audio noise free operation
- Peak load operation with increased frequency
- Comprehensive protection coverage
  - VCC Under Voltage Lockout with hysteresis (UVLO)
  - VCC Over Voltage Protection (VCC OVP)
  - Cycle-by-cycle over current threshold setting for constant output power limiting over universal input voltage range
  - Over Load Protection (OLP) with auto-recovery
  - External (if NTC resistor is connected at PRT pin) or internal Over Temperature Protection (OTP) with latched shut down
  - Output Over Voltage Protection (Output OVP) with latched shut down, and the OVP triggered voltage can be adjusted by the resistor connected between auxiliary winding and PRT pin
  - Output diode short protection with auto-recovery
  - GND open protection with auto-recovery

### TYPICAL APPLICATION

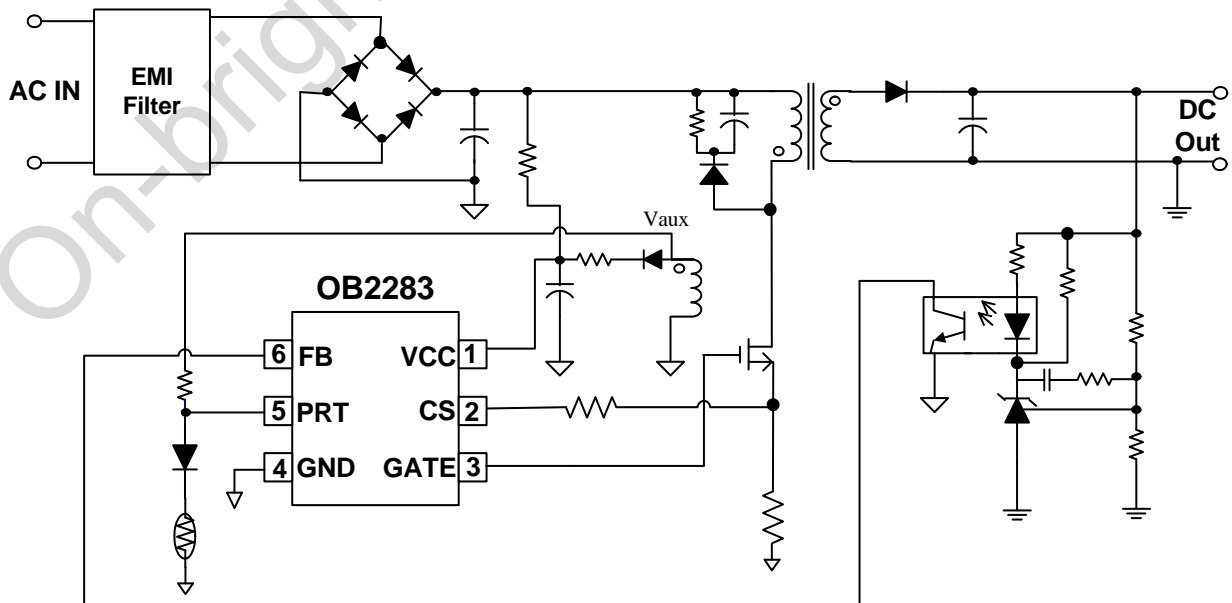

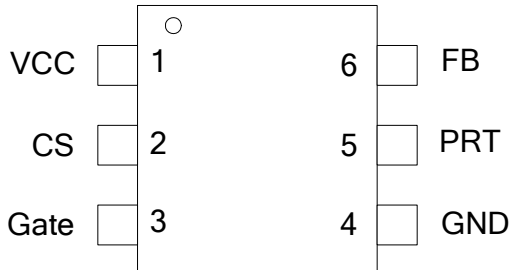
**GENERAL INFORMATION**
**Pin Configuration**

**Ordering Information**

Part Number	Description
OB2283MP	SOT23-6, Pb-free in T&R

**Package Dissipation Rating**

Package	R $\theta$ JA(°C/W)
SOT23-6	200

**Recommended operating condition**

Symbol	Parameter	Range
VCC	VCC Supply Voltage	12 to 28V
T <sub>A</sub>	Operating Ambient Temperature	-20 to 85 °C

**Absolute Maximum Ratings**

Parameter	Value
VCC DC Supply Voltage	V <sub>OV</sub> P-1V
FB Input Voltage	-0.3 to 7V
CS Input Voltage	-0.3 to 7V
PRT Input Voltage	-0.3 to 7V
Min/Max Operating Junction Temperature T <sub>J</sub>	-40 to 150 °C
Min/Max Storage Temperature T <sub>stg</sub>	-55 to 150 °C
Lead Temperature (Soldering, 10secs)	260 °C

**Note:** Stresses beyond those listed under "absolute maximum ratings" may cause permanent damage to the device. These are stress ratings only, functional operation of the device at these or any other conditions beyond those indicated under "recommended operating conditions" is not implied. Exposure to absolute maximum-rated conditions for extended periods may affect device reliability.

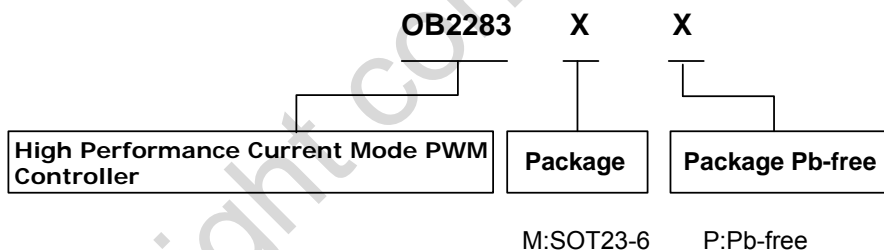
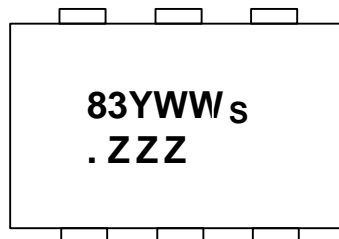

**Marking Information**

Y:Year Code  
 WW:Week Code(01-52)  
 s: Internal code  
 ZZZ: Lot code

**TERMINAL ASSIGNMENTS**

Pin Name	I/O	Description
VCC	P	Power Supply
CS	I	Current sense input
Gate	O	Totem-pole gate driver output for power MOSFET
GND	P	Ground
PRT	I	Dual functions pin. Connecting a NTC resistor to ground for OTP detection. Connecting a resistor from Vaux can adjust OVP trigger voltage. If both OTP and OVP are needed, a diode should be connected between PRT pin and the NTC resistor.
FB	I	Feedback input pin. The PWM duty cycle is determined by voltage level into this pin and the current-sense signal at Pin CS.

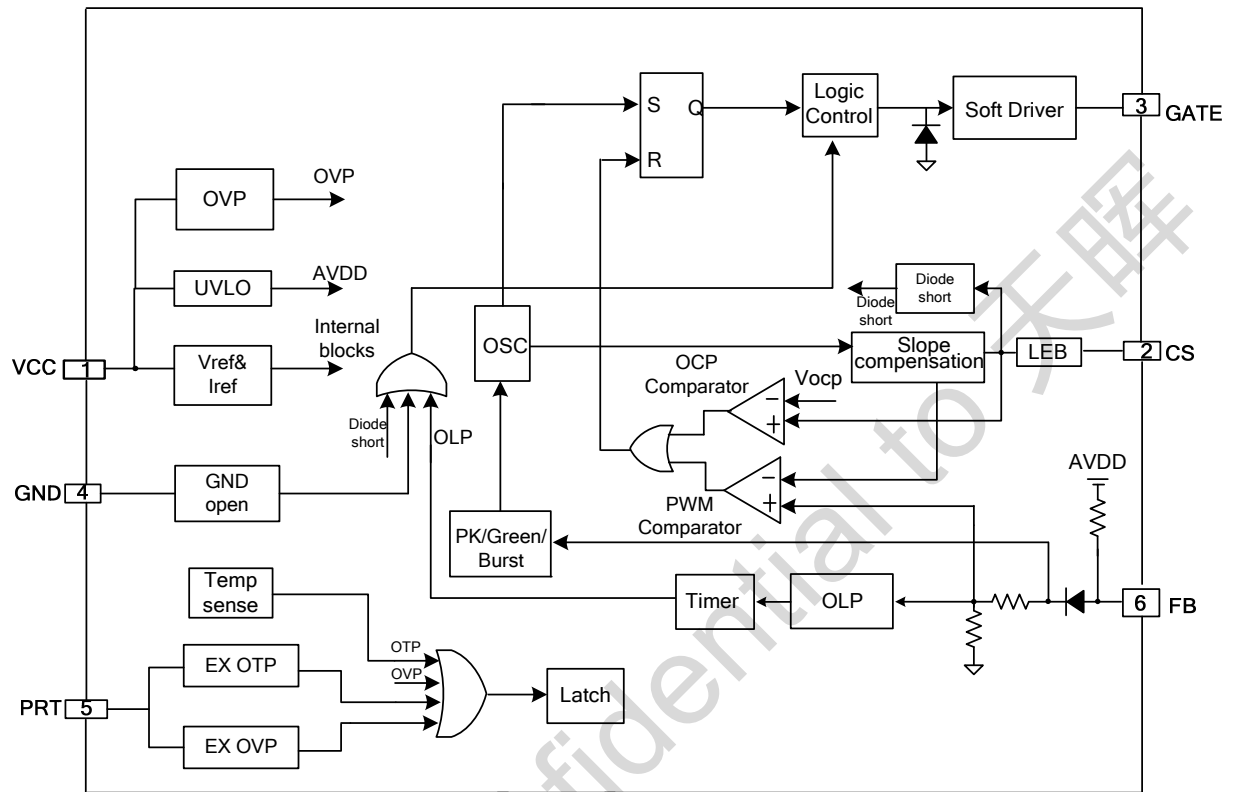
**FUNCTIONAL BLOCK DIAGRAM**



**ELECTRICAL CHARACTERISTICS**

 (T<sub>A</sub> = 25°C, V<sub>CC</sub>=18V, unless otherwise noted)

Symbol	Parameter	Test Conditions	Min	Typ	Max	Unit
<b>Supply Voltage (VDD)</b>						
I <sub>startup</sub>	VCC Start up Current	VCC=UVLO(OFF)-1V, measure leakage current into VCC		3	10	uA
I <sub>VCC_Operation</sub>	Operation Current	VDD=18V,CS=4V, FB=3.5V,measure I(VCC)		2.5	3	mA
I <sub>VCC_Burst</sub>	Burst Current	CS=0V,FB=0.5V, measure I(VCC)		0.55	0.65	mA
UVLO(ON)	VCC Under Voltage Lockout Enter		7	8	9	V
UVLO(OFF)	VCC Under Voltage Lockout Exit (Recovery)		19	21	23	V
V <sub>pull-up</sub>	Pull-up PMOS active			10		V
OVP	VCC Over Voltage Protection threshold voltage	FB=3V,CS=0V. Slowly ramp VCC, until no gate switching.	29	30	31	V
V <sub>latch_release</sub>	Latch release voltage			5		V
<b>Feedback Input Section(FB Pin)</b>						
V <sub>FB_Open</sub>	V <sub>FB</sub> Open Loop Voltage			5.1		V
A <sub>vcs</sub>	PWM input gain ΔVFB/ΔVCS			3.5		V/V
Maximum duty cycle	Max duty cycle @ VCC=18V,VFB=3V,VCS=0V		75	78	81	%
V <sub>ref_green</sub>	The threshold enter green mode			1.85		V
V <sub>ref_burst_H</sub>	The threshold exits burst mode			1.33		V
V <sub>ref_burst_L</sub>	The threshold enters burst mode			1.23		V
I <sub>FB_Short</sub>	FB pin short circuit current	Short FB pin to GND and measure current		0.3		mA
V <sub>TH_OLP</sub>	Open loop protection, FB Threshold Voltage			4.4		V
T <sub>d_OLP</sub>	Open loop protection, Debounce Time			15		ms
Z <sub>FB_IN</sub>	Input Impedance			16		Kohm
<b>Current Sense Input(CS Pin)</b>						
SST_CS	Soft start time for CS peak			4		ms
T <sub>blanking</sub>	Leading edge blanking time			250		ns
T <sub>d_OC</sub>	Over Current Detection and Control Delay	From Over Current Occurs till the Gate driver output start to turn off		90		ns
V <sub>TH_OC</sub>	Internal Current Limiting Threshold Voltage with zero duty cycle		0.43	0.45	0.47	V
V <sub>TH_OC_Clamp</sub>	OCP CS voltage clamper			0.69		V
V <sub>diode_scp</sub>	Diode short protection voltage			1.4		V
T <sub>d_dio</sub>	Diode short debounce time			8		Cycles

Vgnd_open	GND open protection voltage difference between GND and CS			0.3		V
Td_gnd_open	GND open protection debounce time			20		us
Td_OCP	Over Current protection debounce Time			60		ms
<b>PRT pin</b>						
IRT	Output current for external OTP detection		95	100	105	uA
VOTP	Threshold voltage for external OTP		0.95	1	1.05	V
Td_OTP	External OTP debounce time			5		Cycles
Ioutput_ovp	Current threshold for adjustable output OVP			70		uA
Td_output_ovp	Output OVP debounce time			5		Cycles
<b>In-chip OTP</b>						
OTP enter				150		°C
OTP exit				120		°C
<b>Oscillator</b>						
F <sub>osc</sub>	Normal Oscillation Frequency	VDD=18V,FB=3V, CS=0V	60	65	70	KHz
F <sub>osc_PK</sub>	Peak frequency	VDD=18V,FB=4.5V, CS=0V		142		KHz
SST_freq	Soft start time of frequency			30		ms
Δf <sub>OSC</sub>	Frequency jittering			+/-6		%
F <sub>shuffling</sub>	Shuffling frequency			32		Hz
Δf <sub>Temp</sub>	Frequency Temperature Stability			1		%
Δf <sub>VCC</sub>	Frequency Voltage Stability			1		%
F <sub>Burst</sub>	Burst Mode Switch Frequency			25		KHz
<b>Gate driver</b>						
VOL	Output low level @ VDD=18V, I <sub>o</sub> =5mA				1	V
VOH	Output high level @ VCC=18V, I <sub>o</sub> =20mA		6			V
V <sub>clamping</sub>	Output clamp voltage			12		V
T <sub>r</sub>	Output rising time 1.2V ~ 10.8V @ CL=1000pF			160		ns
T <sub>f</sub>	Output falling time 10.8V ~ 1.2V @ CL=1000pF			50		ns

**CHARACTERIZATION PLOTS**

VDD = 18V, TA = 25°C condition applies if not otherwise noted.

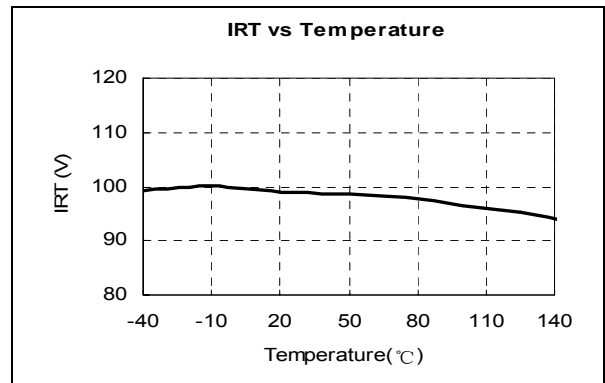
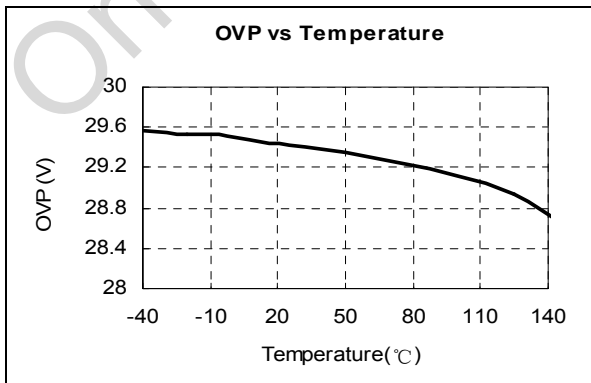
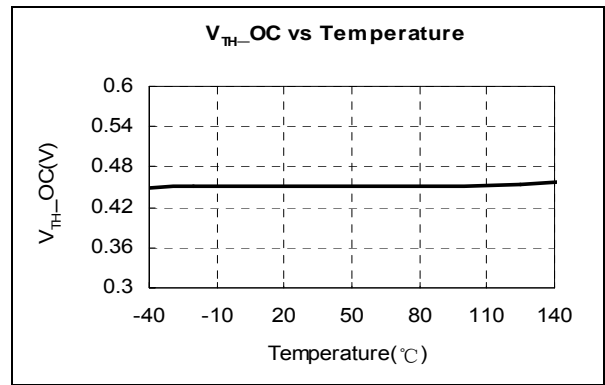
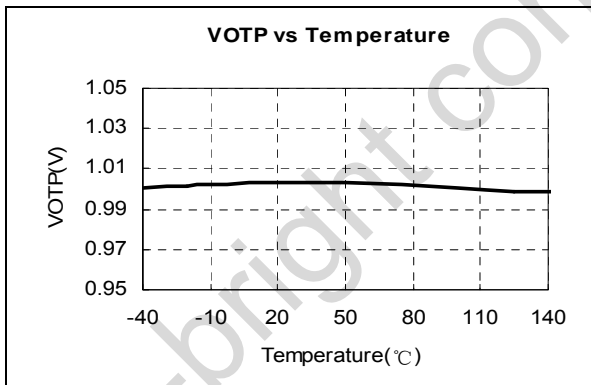
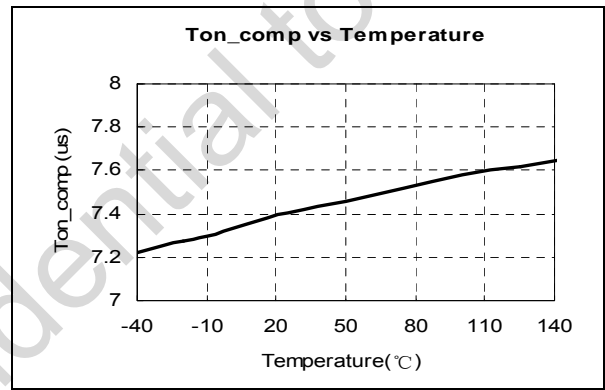
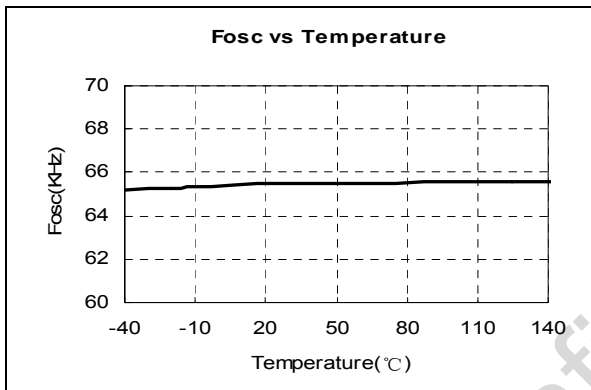
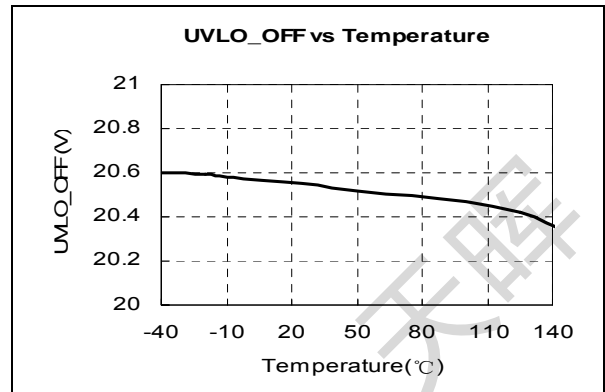
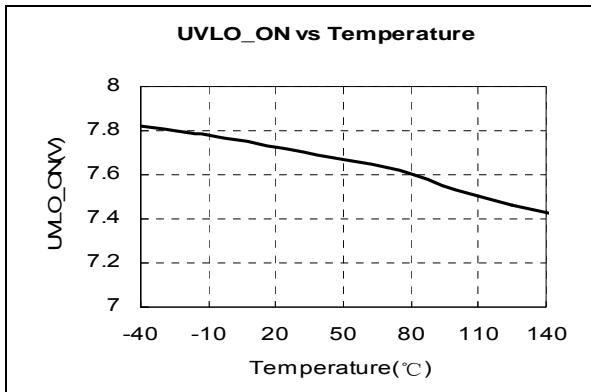

## OPERATION DESCRIPTION

OB2283 is a highly integrated current mode PWM control IC optimized for high performance, low standby power and cost effective offline flyback converter applications. The 'extended burst mode' control greatly reduces the standby power consumption and helps the design easier to meet the international power conservation requirements.

- **Startup Current and Start up Control**

Startup current of OB2283 is designed to be very low so that VCC could be charged up above UVLO threshold level and device starts up quickly. A large value startup resistor can therefore be used to minimize the power loss yet achieve a reliable startup in application.

- **Operating Current**

The Operating current of OB2283 is low at 2.5mA (typical). Good efficiency is achieved with OB2283 low operation current together with the 'extended burst mode' control features.

- **Soft Start**

OB2283 features an internal 4ms (typical) soft start to soften the electrical stress occurring in the power supply during startup. It is activated during the power on sequence. As soon as VCC reaches UVLO(OFF), the CS peak voltage is gradually increased from 0.05V to the maximum level. Every restart up is followed by a soft start.

- **Frequency shuffling for EMI improvement**

The frequency shuffling (switching frequency modulation) is implemented in OB2283. The oscillation frequency is modulated so that the tone energy is spread out. The spread spectrum minimizes the conduction band EMI and therefore eases the system design.

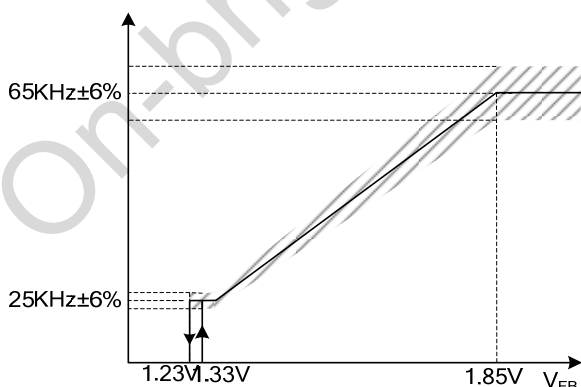

- **Extended Burst Mode Operation**

At light load or no load condition, most of the power dissipation in a switching mode power supply is from switching loss of the MOSFET, the core loss of the transformer and the loss of the

snubber circuit. The magnitude of power loss is in proportion to the switching frequency. Lower switching frequency leads to the reduction on the power loss and thus conserves the energy.

The switching frequency is internally adjusted at no load or light load condition. The switch frequency reduces at light/no load condition to improve the conversion efficiency. At light load or no load condition, the FB input drops below Vref\_burst\_L (the threshold enter burst mode) and device enters Burst Mode control. The Gate drive output switches when FB input rises back to Vref\_burst\_H (the threshold exit burst mode). Otherwise the gate drive remains at off state to minimize the switching loss and reduces the standby power consumption to the greatest extend.

- **Oscillator Operation**

During the full load power operation, OB2283 operates at a 65KHz (typical) fixed frequency. The efficiency and system cost is controlled at an optimal level. A peak power mode is implemented to supply a peak current output requirement. In peak power mode, frequency is increased from 65KHz (typical) to 142KHz (typical).

At light load levels, OB2283 enters the light load mode, where the output current is reduced. The switching losses are reduced by lowering the switching frequency.

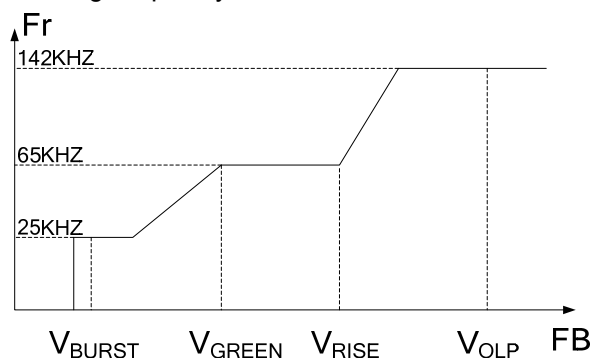

- **Current Sensing and Leading Edge Blanking**

Cycle-by-Cycle current limiting is offered in OB2283 current mode PWM control. The switch current is detected by a sense resistor into the CS pin. An internal leading edge blanking circuit chops off the sensed voltage spike at initial internal power MOSFET on state due to snubber diode reverse recovery and surge gate current of power MOSFET. The current limiting comparator is disabled and cannot turn off the internal power MOSFET during the blanking period. The PWM



duty cycle is determined by the current sense input voltage and the FB input voltage.

- Internal Synchronized Slope Compensation**  
 Built-in slope compensation circuit adds voltage ramp into the current sense input voltage for PWM generation. This greatly improves the close loop stability at CCM and prevents the sub-harmonic oscillation and thus reduces the output ripple voltage.

- Driver**  
 The power MOSFET is driven by a dedicated gate driver for power switch control. Too weak the gate driver strength results in higher conduction and switch loss of MOSFET while too strong gate driver strength results the compromise of EMI. A good tradeoff is achieved through the built-in totem pole gate design with right output strength and dead time control. The low idle loss and good EMI system design is easier to achieve with this dedicated control scheme.

- Dual Function of External OTP and Output OVP**

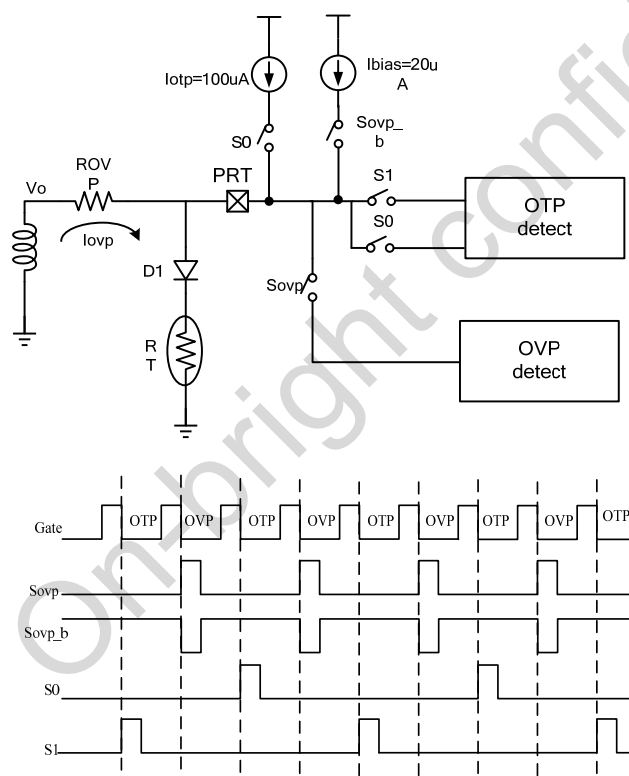

On-Bright proprietary dual function of external OTP and output OVP provides feasible and accurate detection of external OTP through NTC resistor and output OVP. The dual function is

realized through time-division technology as shown in the figure.

For external OTP detection, when switch control signal S1= "1", about 20uA (typical) current flows out from PRT pin. When switch control signal S0= "1", about 120uA (typical) current flows out from PRT pin. The PRT pin voltage difference  $\Delta V_{otp}$  at phase S0 and S1 phase is equal to  $R_T \cdot I_{otp}$ . When  $\Delta V_{otp} < 1V$ , external OTP latch protection is triggered after 5 Gate cycles debounce.

For output OVP detection, when  $S_{ovp} = "1"$ ,  $I_{ovp}$  is equal to  $V_o / R_{OVP}$ . If  $I_{ovp}$  is larger than 70uA (typical), OVP latch protection is triggered after 5 Gate cycles debounce. By selecting proper  $R_{ovp}$  resistance, output OVP level can be programmed.

- Protection Controls**

Good power supply system reliability is achieved with auto-recovery protection features including Cycle-by-Cycle current limiting (OCP), and Under Voltage Lockout on VDD (UVLO), and latched shutdown features including Over Temperature Protection (OTP), VCC and output Over Voltage Protection (OVP).

With On-Bright proprietary technology, the OCP is line voltage compensated to achieve constant output power limit over the universal input voltage range.

At overload condition when FB input voltage exceeds power limit threshold value for more than  $T_{d\_OLP}$ , control circuit reacts to shut down the converter. It restarts when VDD voltage drops below UVLO limit. For protection with latched shut down mode, control circuit shuts down (latch) the power MOSFET when an over temperature condition or over voltage condition is detected until VDD drops below 5V (typical) (Latch release voltage), and the device enters power on restart-up sequence thereafter.

At output diode short condition, CS can ramp higher than 1.4V (typical). After 8 cycles debounce time for CS higher than 1.4V (typical), auto-recover protection is triggered.

At GND open condition, the voltage of GND is higher than CS. If GND is greater than  $CS + 0.3V$  (typical) for more than 20us (typical), auto-recover protection is triggered.

- Pin Floating and Short Protection**

OB2283 provides PIN floating protection for all the pins and pin short protection for adjacent pins. In the cases when a pin is floating or two adjacent pins are shorted, Gate switching is disabled.

**PACKAGE MECHANICAL DATA**

**SOT-23-6L PACKAGE OUTLINE DIMENSIONS**

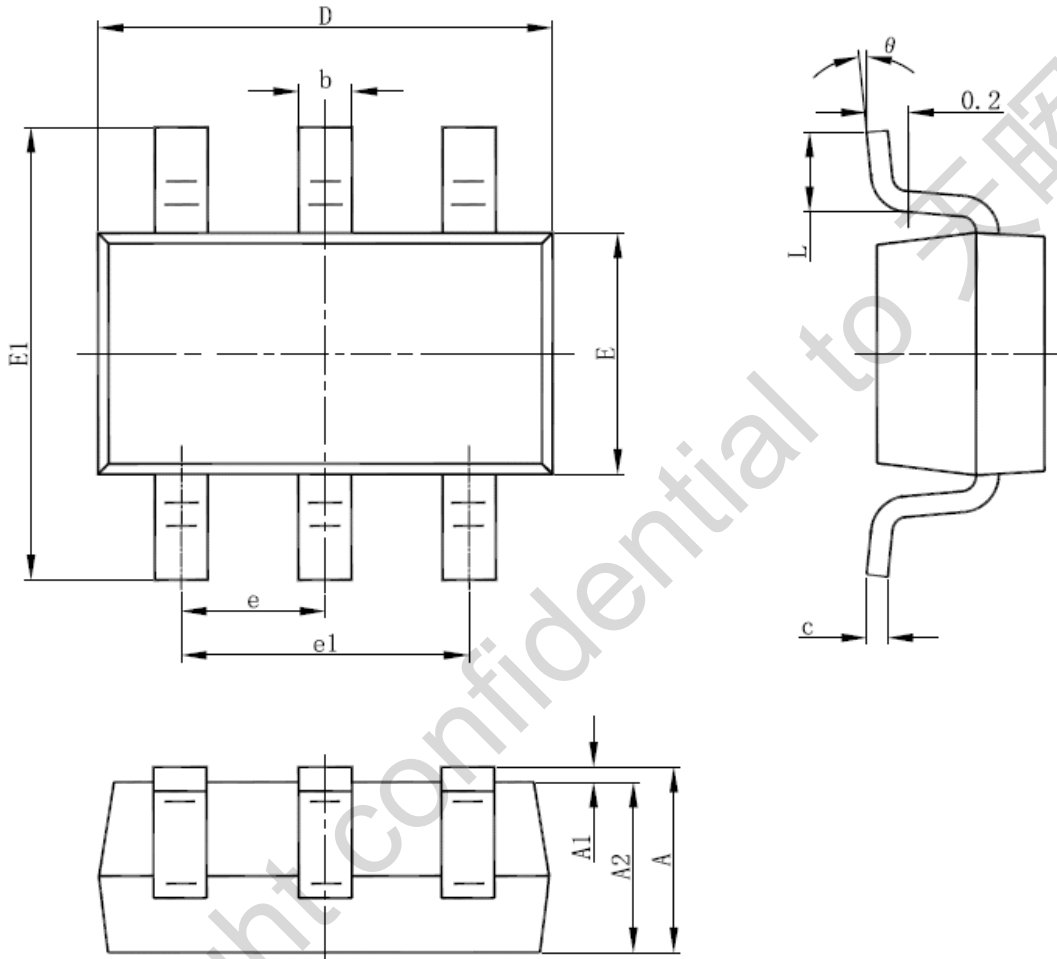

Symbol	Dimensions In Millimeters		Dimensions In Inches	
	Min	Max	Min	Max
A	1.000	1.450	0.039	0.057
A1	0.000	0.150	0.000	0.006
A2	0.900	1.300	0.035	0.051
b	0.300	0.500	0.012	0.020
c	0.080	0.220	0.003	0.009
D	2.800	3.020	0.110	0.119
E	1.500	1.726	0.059	0.068
E1	2.600	3.000	0.102	0.118
e	0.950 (BSC)		0.037 (BSC)	
e1	1.800	2.000	0.071	0.079
L	0.300	0.600	0.012	0.024
θ	0°	8°	0°	8°

## **IMPORTANT NOTICE**

### **RIGHT TO MAKE CHANGES**

On-Bright Electronics Corp. reserves the right to make corrections, modifications, enhancements, improvements and other changes to its products and services at any time and to discontinue any product or service without notice. Customers should obtain the latest relevant information before placing orders and should verify that such information is current and complete.

### **WARRANTY INFORMATION**

On-Bright Electronics Corp. warrants performance of its hardware products to the specifications applicable at the time of sale in accordance with its standard warranty. Testing and other quality control techniques are used to the extent it deems necessary to support this warranty. Except where mandated by government requirements, testing of all parameters of each product is not necessarily performed.

On-Bright Electronics Corp. assumes no liability for application assistance or customer product design. Customers are responsible for their products and applications using On-Bright's components, data sheet and application notes. To minimize the risks associated with customer products and applications, customers should provide adequate design and operating safeguards.

### **LIFE SUPPORT**

On-Bright Electronics Corp.'s products are not designed to be used as components in devices intended to support or sustain human life. On-bright Electronics Corp. will not be held liable for any damages or claims resulting from the use of its products in medical applications.

### **MILITARY**

On-Bright Electronics Corp.'s products are not designed for use in military applications. On-Bright Electronics Corp. will not be held liable for any damages or claims resulting from the use of its products in military applications.