

Single Operational Amplifier



General Description

The FP703 is a single chip composed of one op-amp (OPA) with open collector output. It offers space and low cost in many applications such as the secondary feedback control of power supply, AC to DC converter or adaptor.

The FP703 is designed to act as OCP detector with few external components. The circuit diagram for typical application example is shown as below.

Features

- Wide Operating Voltage from 3.0V~25V
- Open Collector Output
- Sink Current up to 20mA
- Low Input Offset Voltage: 1mV
- Package: SOT23-5L

Typical Application Circuit

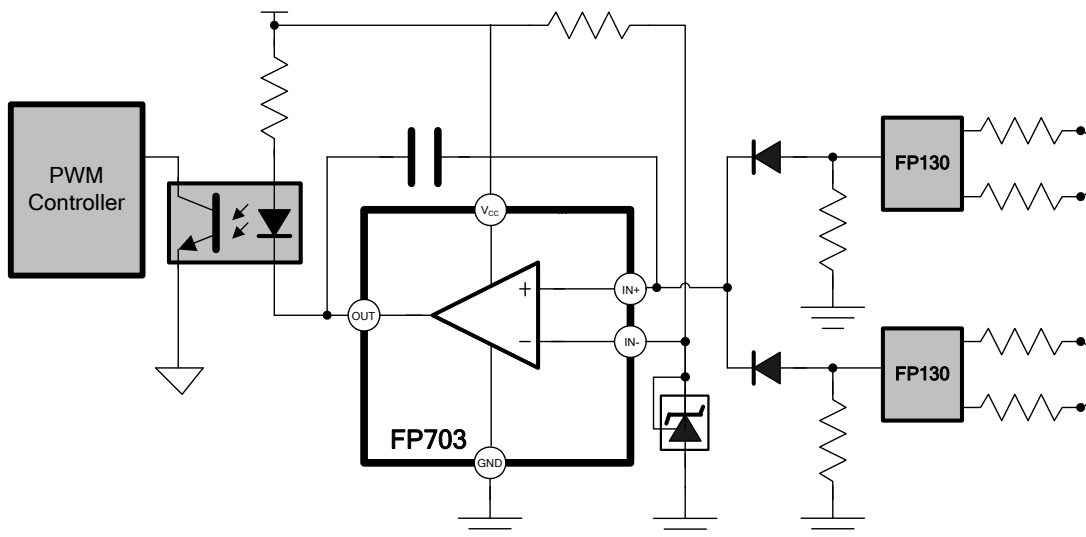

Function Block Diagram

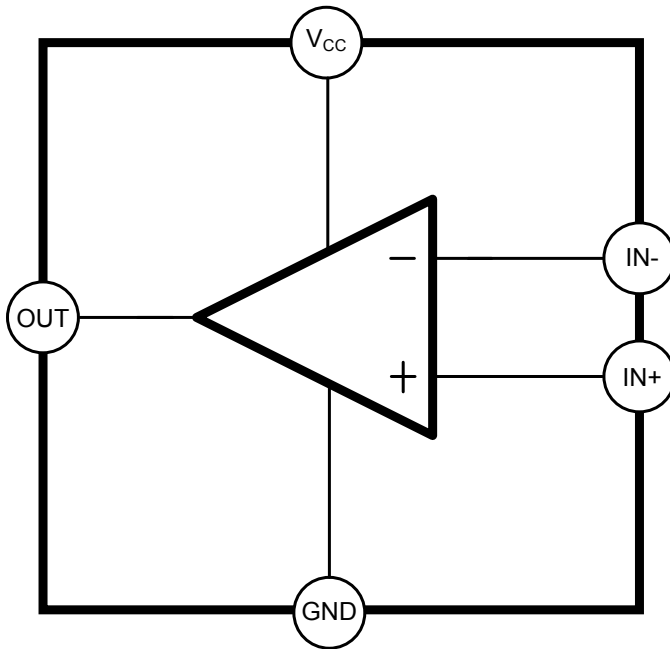

Pin Descriptions

SOT23-5L

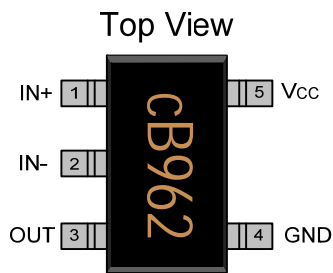

Name	No.	I / O	Description
IN+	1	I	OPA Non-Inverting Input
IN-	2	I	OPA Inverting Input
OUT	3	O	OPA Open Collector Output
GND	4	P	IC Ground
V _{CC}	5	P	IC Power Supply

Marking Information

SOT23-5L

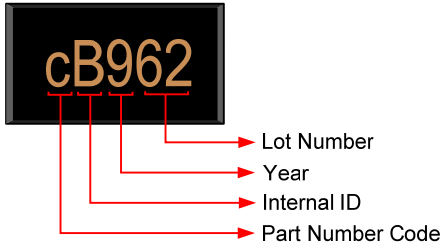

Lot Number: Wafer lot number's last two digits

For Example: 132362TB → 62

Year: Production year's last digit

Internal ID: Internal Identification Code

Part Number Code: Part number identification code for this product. It should be always "c".

Ordering Information

Part Number	Operating Temperature	Package	MOQ	Description
FP703KR-LF	-20°C ~ +85°C	SOT23-5L	2500EA	Tape & Reel

Absolute Maximum Ratings

Parameter	Symbol	Conditions	Min.	Typ.	Max.	Unit
Input Voltage			-0.3		V_{CC}	V
Differential Input Voltage	V_{ID}				± 20	V
Output Voltage					25	V
Output Sink Current					30	mA
Maximum Junction Temperature		SOT23-5L			+150	°C
Thermal Resistance Junction to Ambient	θ_{JA}				+400	°C / W
Power Dissipation	P_D				250	mW
Storage Temperature Range			-65		+150	°C
Lead Temperature (soldering, 10 sec)					+260	°C

IR Re-flow Soldering Curve

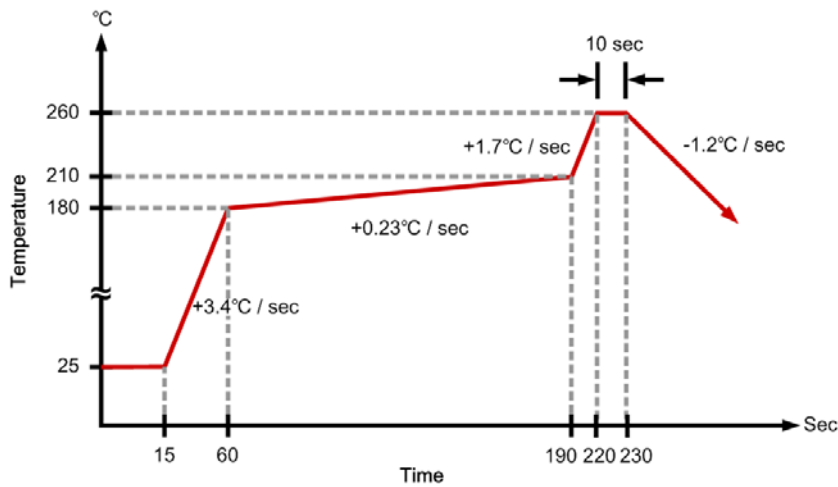

This datasheet contains new product information. Feeling Technology reserves the rights to modify the product specification without notice. No liability is assumed as a result of the use of this product. No rights under any patent accompany the sales of the product.

Recommended Operating Conditions

Parameter	Symbol	Conditions	Min.	Typ.	Max.	Unit
Supply Voltage	V_{CC}		3		25	V
Operating Temperature			-20		+85	°C

DC Electrical Characteristics

($V_{CC}=12V$, $T_A=25^{\circ}C$, unless otherwise noted)

Parameter	Symbol	Conditions	Min.	Typ.	Max.	Unit
Operating Amplifier						
Input Offset Voltage	V_{IO}	$T_{AMB}=25^{\circ}C$		1	3	mV
		$T_{MIN} \leq T_{AMB} \leq T_{MAX}$			5	
Input Offset Voltage Drift	DV_{IO}			7		$\mu V / ^{\circ}C$
Input Bias Current	I_{ib}	$T_{AMB}=25^{\circ}C$		-80	-250	nA
		$T_{MIN} \leq T_{AMB} \leq T_{MAX}$			-500	
Large Signal Voltage Gain	A_{vd}			50		V / mV
Output Sink Current	I_{SINK}	$V_{IN-}=0.8V$, $V_{OUT}=1.2V$		30		mA
Low Level Output Voltage	V_{OL}	$V_{IN-}=0.8V$, $I_{SINK}=20mA$		0.9	1	V
Output Leakage Current	I_{LEAK}	$V_{OUT}=25V$, $V_{ID-}=0.8V$		0.1	1	μA
Total Supply Current						
IC Supply Current	I_{CC}	$V_{CC}=25V$		0.4		mA

Typical Operating Characteristics

($V_{CC}=12V$, $T_A=25^{\circ}C$, unless otherwise noted)

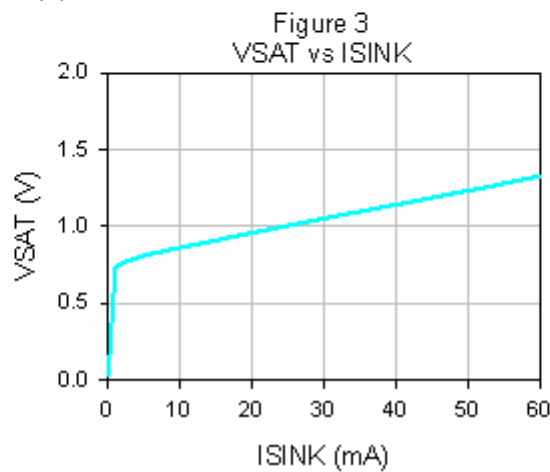
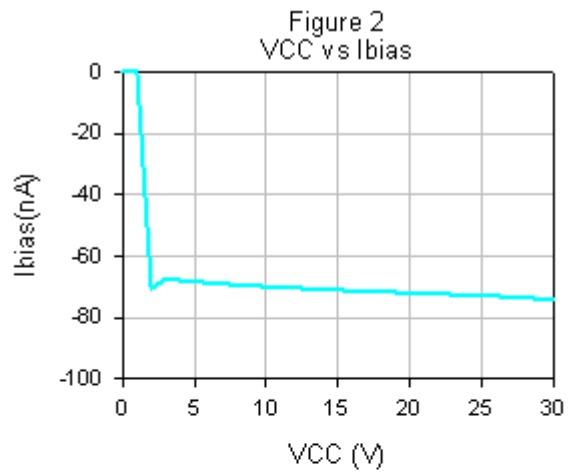
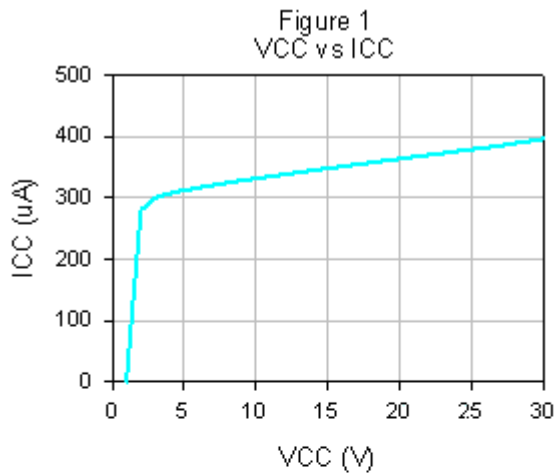

IN- to V_{OUT} Delay Time (T_A=25°C, V_{CC}=12V, R_{OUT}=2K)

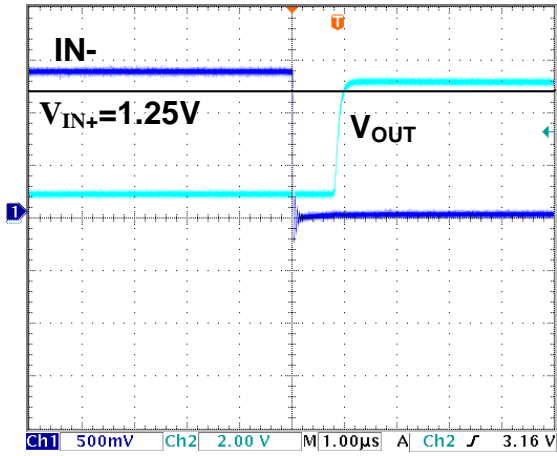

Figure 4

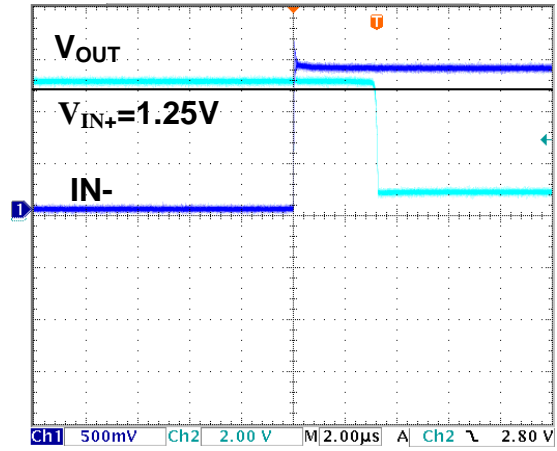
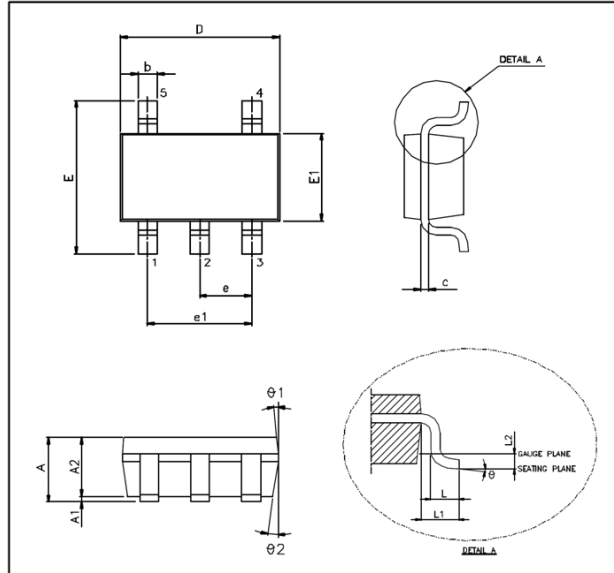

Figure 5

Package Outline SOT23-5L

UNIT: mm

Symbols	Min. (mm)	Max.(mm)
A	1.050	1.350
A1	0.050	0.150
A2	1.000	1.200
b	0.250	0.500
c	0.080	0.200
D	2.700	3.000
E	2.600	3.000
E1	1.500	1.700
e	0.950 BSC	
e1	1.900 BSC	
L	0.300	0.550
L1	0.600 REF	
L2	0.250 BSC	
θ°	0°	10°
$\theta1^\circ$	3°	7°
$\theta2^\circ$	6°	10°

Note:

1. Package dimensions are in compliance with JEDEC outline: MO-178 AA.
2. Dimension "D" does not include molding flash, protrusions or gate burrs.
3. Dimension "E1" does not include inter-lead flash or protrusions.

This datasheet contains new product information. Feeling Technology reserves the rights to modify the product specification without notice. No liability is assumed as a result of the use of this product. No rights under any patent accompany the sales of the product.