

1.0A Output, 2.5MHz Synchronous Buck-Boost DC/DC Converter

FEATURES

- Regulated Output with Input Voltage Above, Below, or Equal to the Output.
- 1A Output Current at 3.3V in Step Down Mode ($V_{IN} = 3.6V$ to $5.5V$).
- Up to 800mA Output Current at 3.3V in Boost Mode ($V_{IN} > 2.8V$).
- Single Inductor.
- 2.5V to 5.5V Input Voltage Range.
- Fixed and Adjustable Output Voltage Options from 1.8V to 5.5V.
- Up to 95% Efficiency.
- Stable with Low ESR Ceramic Capacitors.
- No Schottky Diode Required.
- Output Disconnect in Shutdown.
- $<1\mu A$ Shutdown Current.
- $<60\mu A$ Quiescent Current.
- Power Saving Mode for Improved Light Efficiency Operation.
- Forced Fixed Frequency Operation Mode.
- Load Disconnect During Shutdown.
- Undervoltage Lockout Protection.

APPLICATIONS

- All Three-Cell Alkaline, NiCd or NiMH or Single-Cell Li Battery
- MP3 Players
- Handheld Instruments
- Digital Cameras
- Smart Phones
- Portable GPS Units
- Miniature Hard Disk Drive Power

TYPICAL APPLICATION CIRCUIT

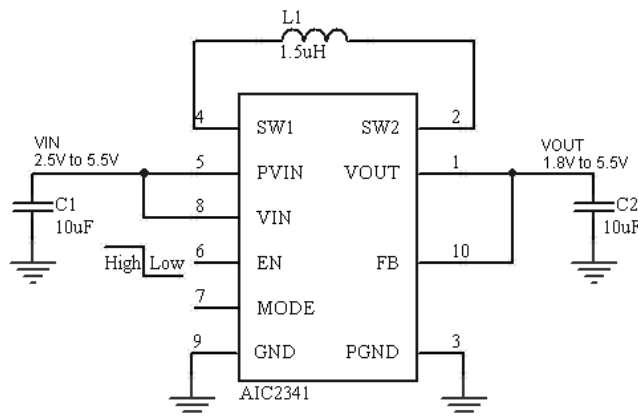

Fig.1 Application Circuit

DESCRIPTION

The AIC2341 is a 1.0A output, low-noise, pulse-width-modulated (PWM) buck-boost DC-DC converter that operates from input voltage above, below, or equal to the output voltage.

The device features two internal synchronous rectifiers for high efficiency; it requires no external Schottky diode. Internally fixed-frequency 2.5MHz operation provides easy post-filtering and allows the use of small inductors and capacitors. At low load currents the converter enters the Power Saving Mode to maintain a high efficiency over a wide load range. The Power Saving Mode could be disabled, forcing AIC2341 to operate at PWM mode. The AIC2341 is ideally suited for single Li-Ion battery applications. It is also useful for three-cell alkaline, NiMH, or NiCd applications. Shutdown mode places the device in standby, reducing quiescent supply current to under $1\mu A$.

Other features of the AIC2341 include internal soft-start, internal compensation, short circuit protection, current limit, and over temperature protection. The device is packaged in a 10-pin DFN package measuring 3 mm x 3 mm.

ORDERING INFORMATION

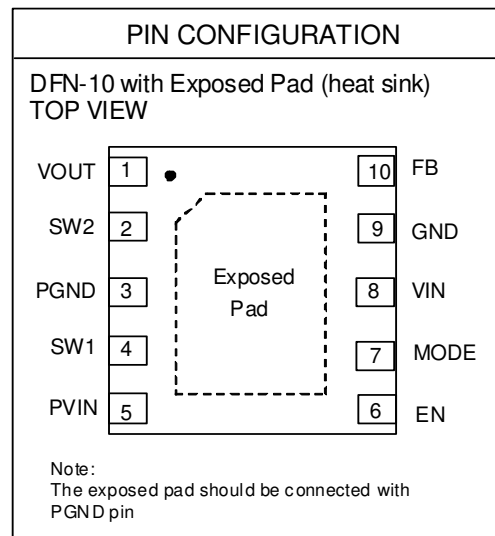
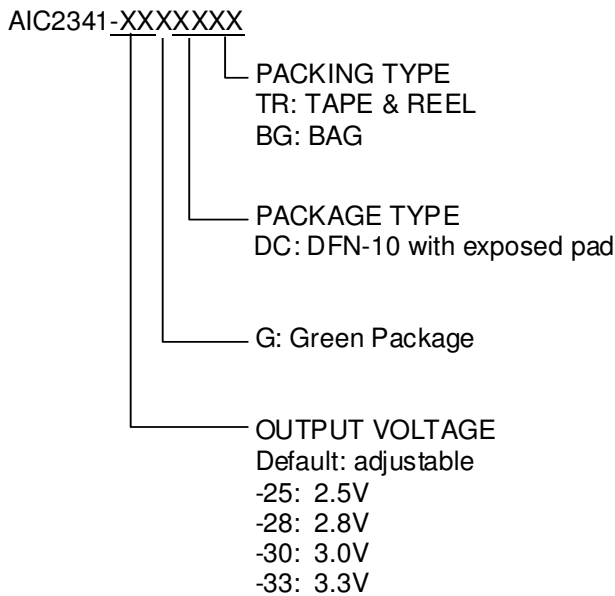

Example: AIC2341-33GDCTR
 → 3.3V Output Version,
 in Green DFN-10 With Exposed Pad
 Package and Tape & Reel Packing
 Type

AIC2341GDCTR
 → Adjustable Version,
 in Green DFN-10 With Exposed Pad
 Package and Tape & Reel Packing
 Type

ABSOLUTE MAXIMUM RATINGS

Input Voltage Range on PVIN, VIN, SW1, SW2, VOUT, MODE, EN, FB	-0.3V to 6V
PGND to GND	-0.3V to 0.3V
Operating Ambient Temperature Range T_A	-40°C~85°C
Operating Maximum Junction Temperature T_J	150°C
Storage Temperature Range T_{STG}	-65°C~150°C
Lead Temperature (Soldering 10 Sec.)	260°C
Thermal Resistance Junction to Case DFN-10L 3x3 (with heat-sink)*	20°C/W
Thermal Resistance Junction to Ambient DFN-10L 3x3 (with heat-sink)*.....	50°C/W

(Assume no Ambient Airflow)

Absolute Maximum Ratings are those values beyond which the life of a device may be impaired.

*The package is place on a two layers PCB with 2 ounces copper and 2 square inch, connected by 8 vias.

ELECTRICAL CHARACTERISTICS

($V_{IN} = 3.6V$, $V_{out} = 3.3V$, unless otherwise specified. Typical values are at $T_A = 25^\circ C$) (Note1)

PARAMETER	SYMBOL	CONDITIONS	MIN	TYP	MAX	UNITS
Input Voltage Range	V_{IN}		2.5		5.5	V
Output Adjustment Range	V_{OUT}		1.8		5.5	V
Feedback Voltage	V_{FB}		0.495	0.5	0.505	V
Feedback Input Impedance	Z_{FB}	$V_{OUT}=3.3V$		1.0		$M\Omega$
High Side Switch On Resistance	R_{DSSH_ON}			200		$m\Omega$
Low Side Switch On Resistance	R_{DSL_ON}			200		$m\Omega$
Switch Current-Limit Threshold	I_{sw}			1.8		A
Quiescent Current	I_Q	$I_{OUT}= 0mA$			60	μA
Shutdown Supply Current	I_{SHDN}	$V_{EN} = 0V$			1	μA
Oscillator Frequency	f_{OSC}		2.2	2.5	2.8	MHz
Line Regulation		$V_{IN}=2.5$ to $3.6V$, $I_{OUT}=0$ to $500mA$,		0.5		%
Load Regulation		PWM mode		0.5		%
Under Voltage Lockout Threshold	V_{UVLO_R}	V_{IN} Rising	2.1		2.4	V
	V_{UVLO_F}	V_{IN} Falling	2.0		2.3	V
EN Low-Level Input Voltage	V_{EN_L}				0.4	V
EN High-Level Input Voltage	V_{EN_H}		1.2			V
Over Temperature Protection				150		$^\circ C$
Over Temperature Protection Hysteresis				30		$^\circ C$

Note 1: Specifications are production tested at $T_A=25^\circ C$. Specifications over the $-40^\circ C$ to $85^\circ C$ operating temperature range are assured by design, characterization and correlation with Statistical Quality Controls (SQC).

■ BLOCK DIAGRAMS

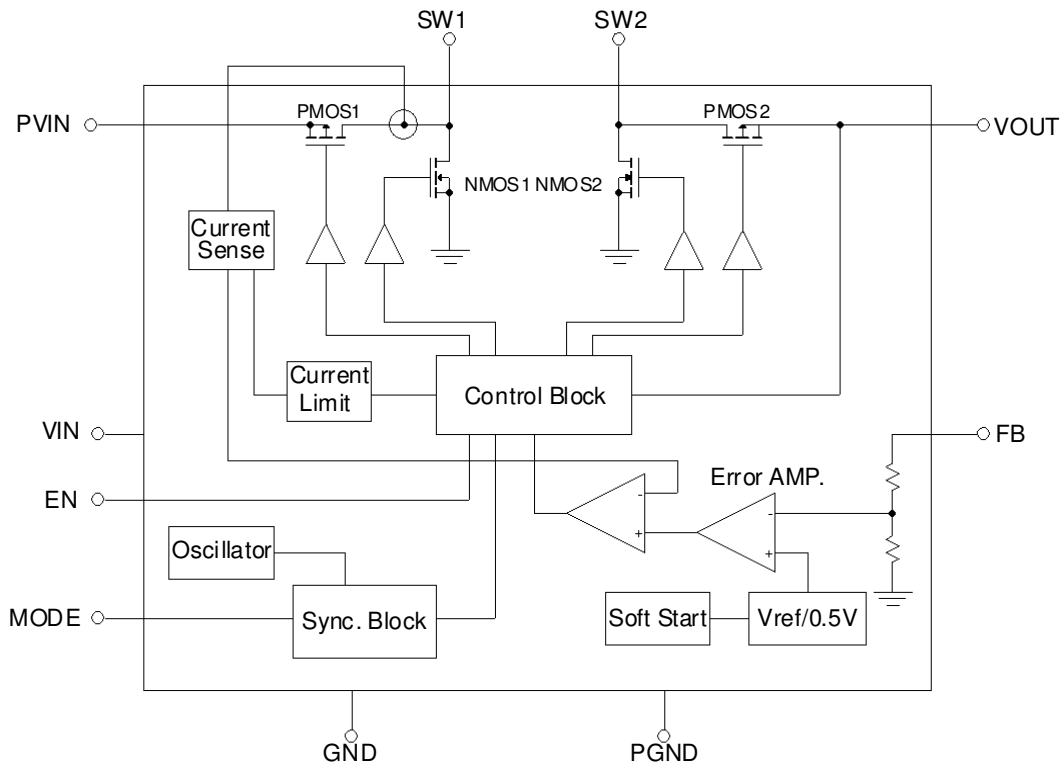

Fig.2 Fixed Output Voltage Version

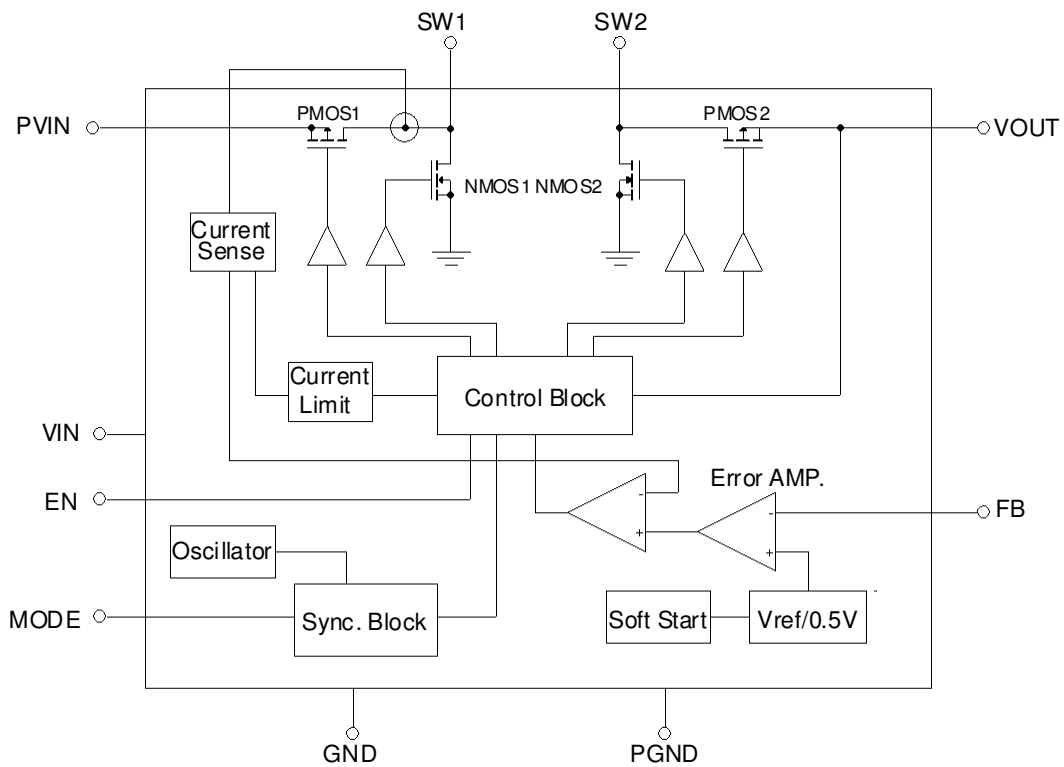

Fig.3 Adjustable Output Voltage Version

■ PIN DESCRIPTIONS

PIN 1: VOUT – Buck-boost converter output.
 PIN 2: SW2 – Connection for inductor.
 PIN 3: PGND – Power ground.
 PIN 4: SW1 – Connection for inductor.
 PIN 5: PVIN – Supply voltage for power stage.
 PIN 6: EN – Enable input (1 enabled, 0 disabled).

PIN 7: MODE – Enable/Disable power save mode (1 disabled, 0 enabled, clock signal for synchronization).
 PIN 8: VIN – Supply voltage for control stage.
 PIN 9: GND – Control / logic ground.
 PIN 10: FB – Voltage feedback of adjustable version, must be connected to VOUT at fixed output voltage version.

■ TYPICAL PERFORMANCE CHARACTERISTICS

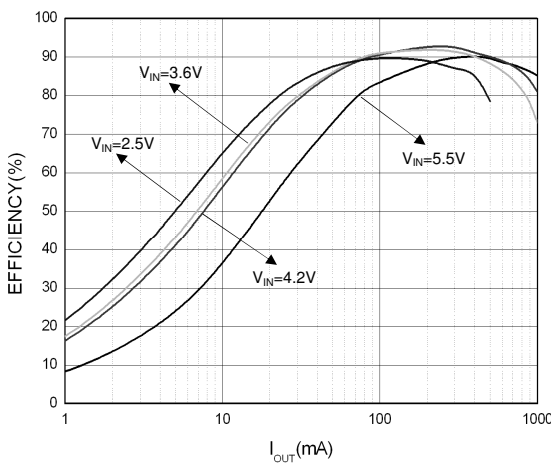

Fig.4 Efficiency vs. Output Current $V_{OUT} = 3.3V$ (PWM Mode)

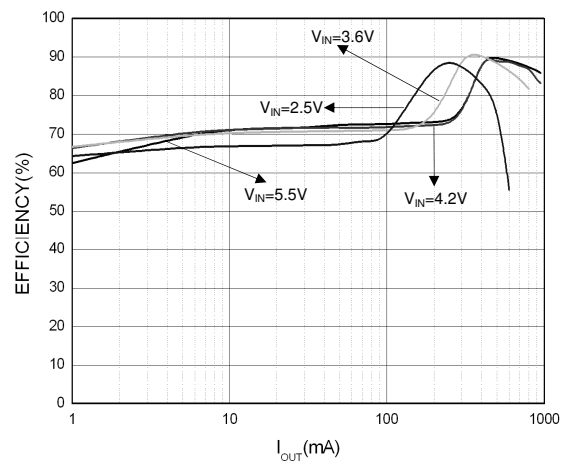

Fig.5 Efficiency vs. Output Current $V_{OUT} = 3.3V$ (PSM Mode)

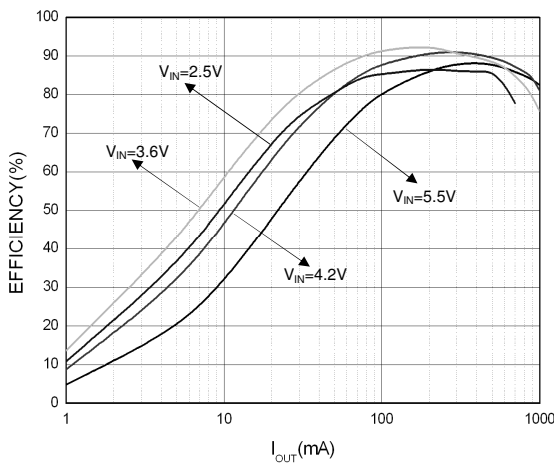

Fig.6 Efficiency vs. Output Current $V_{OUT} = 2.8V$ (PWM Mode)

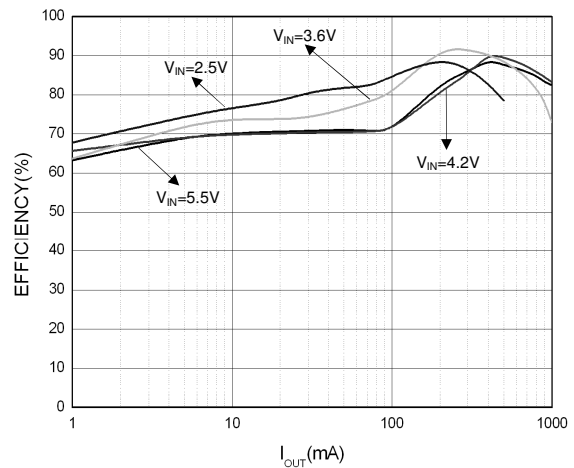

Fig.7 Efficiency vs. Output Current $V_{OUT} = 2.8V$ (PSM Mode)

TYPICAL PERFORMANCE CHARACTERISTICS (Continued)

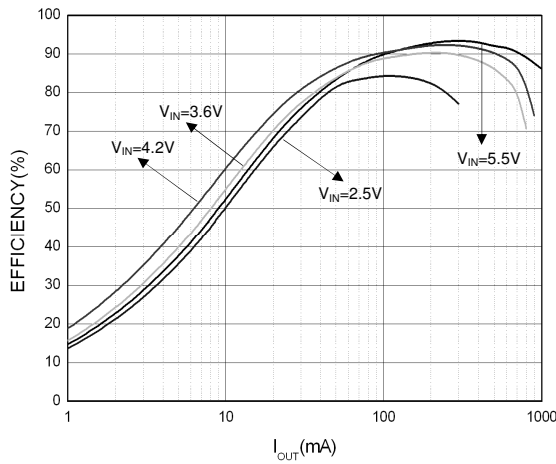

Fig.8 Efficiency vs. Output Current $V_{OUT} = 5V$ (PWM Mode)

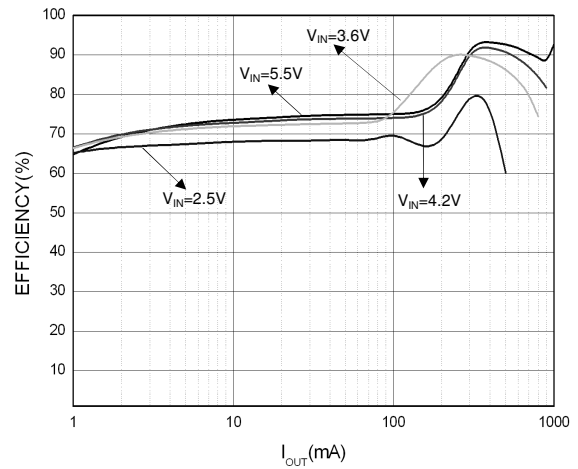

Fig.9 Efficiency vs. Output Current $V_{OUT} = 5V$ (PSM Mode)

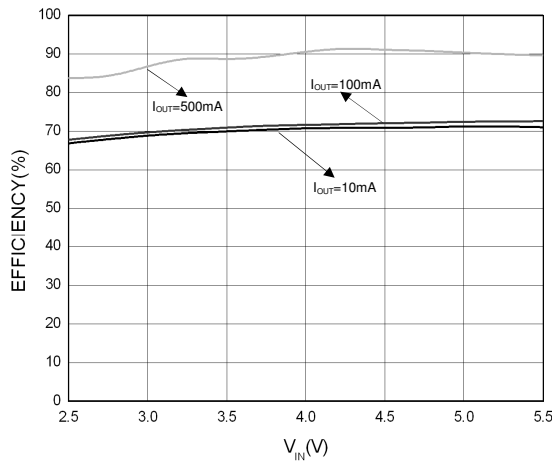

Fig.10 Efficiency vs. Input Voltage $V_{OUT} = 3.3V$ (PSM Mode)

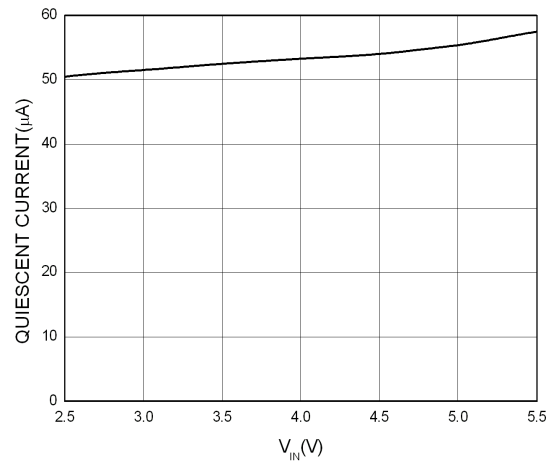

Fig.11 Quiescent Current vs. Input Voltage $V_{OUT} = 3.3V$

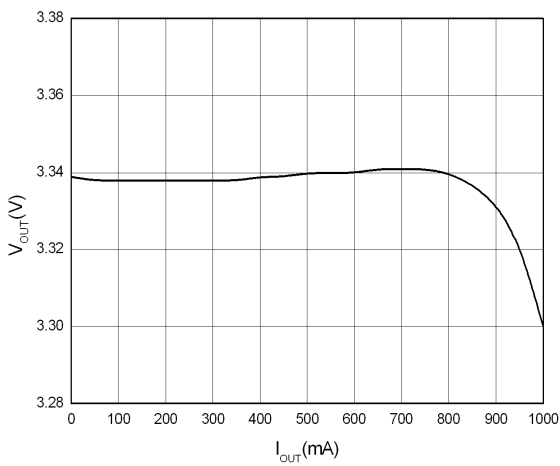

Fig.12 Load Regulation $V_{IN} = 3.6V$ $V_{OUT} = 3.3V$ (PWM Mode)

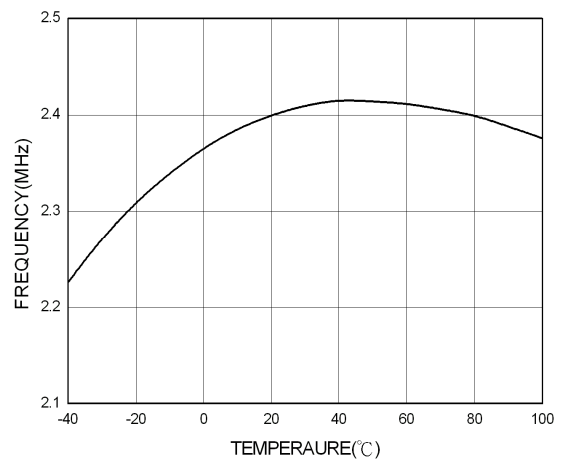

Fig.13 Frequency vs. Temperature ($V_{IN} = 3.6V$)

TYPICAL PERFORMANCE CHARACTERISTICS (Continued)

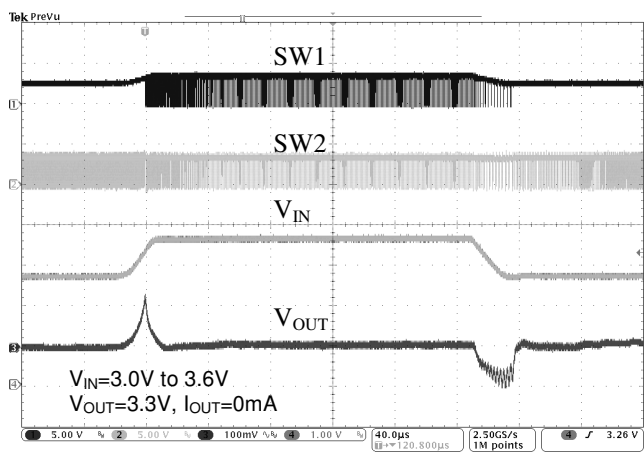

Fig. 14 Line transient (PWM mode)

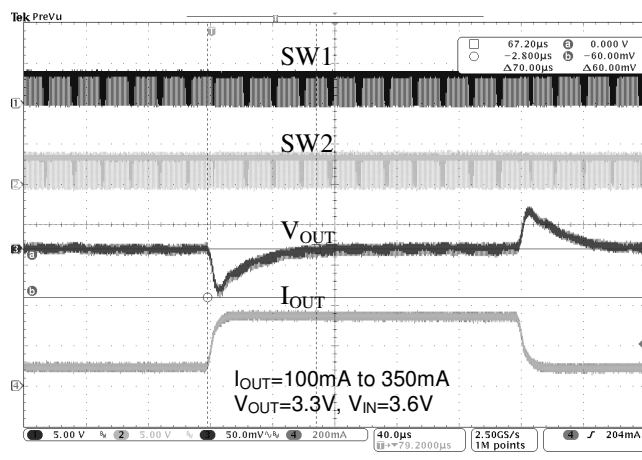

Fig. 15 Load transient (PWM)

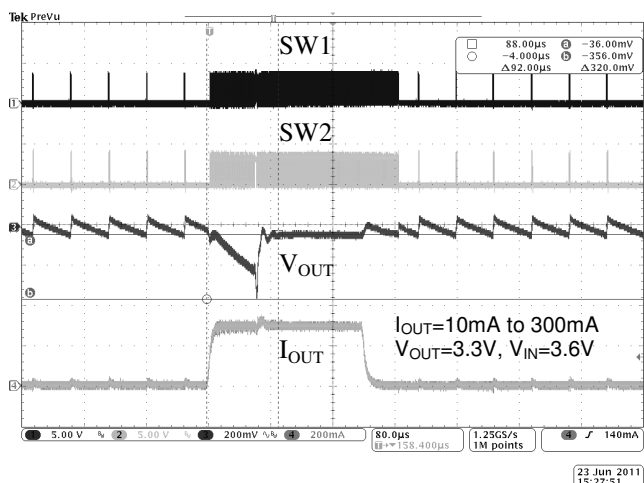

Fig. 16 Load transient (PSM)

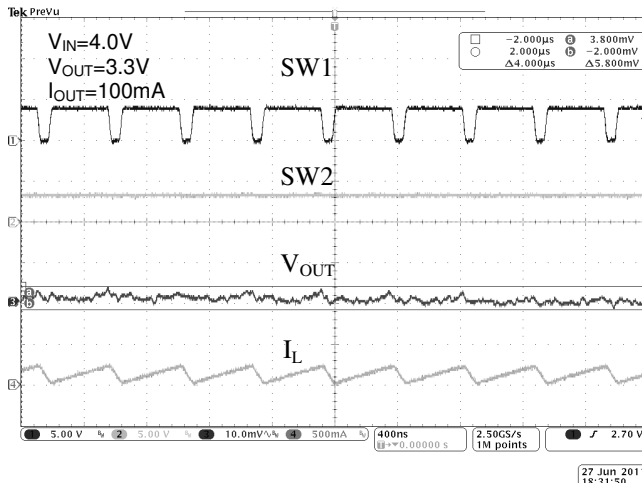

Fig. 17. Buck operation

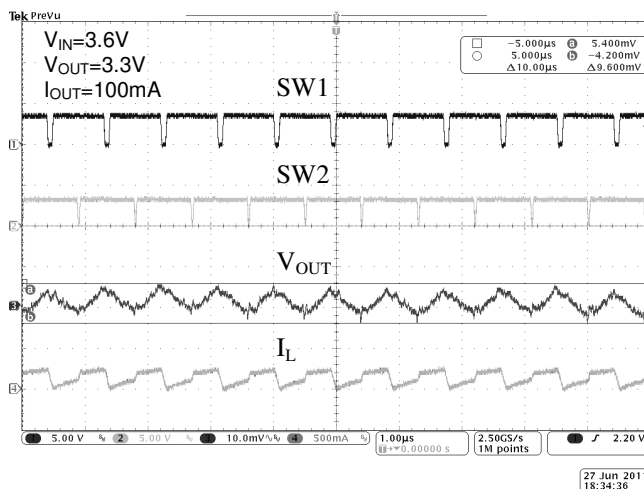

Fig. 18 Buck-Boost Operation

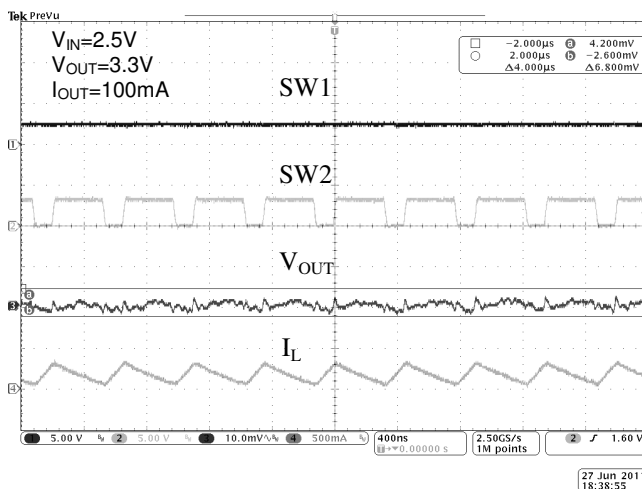

Fig. 19 Boost Operation

TYPICAL PERFORMANCE CHARACTERISTICS (Continued)

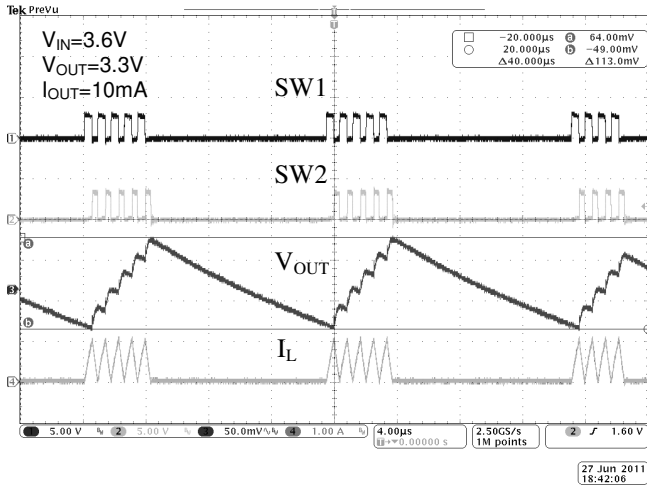

Fig.20 PSM Operation

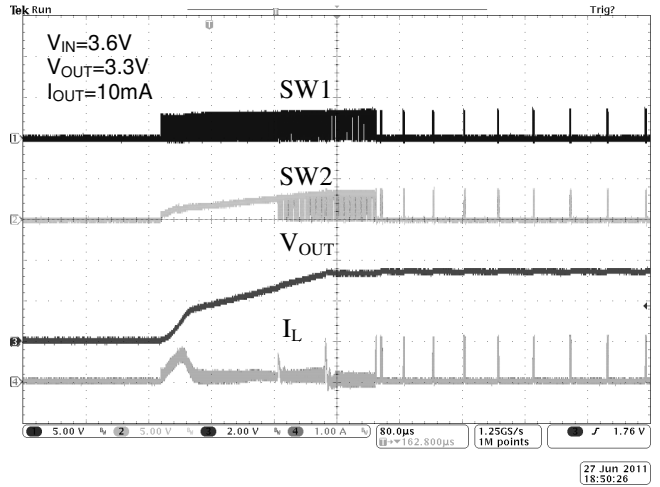

Fig.21 Power ON (PSM)

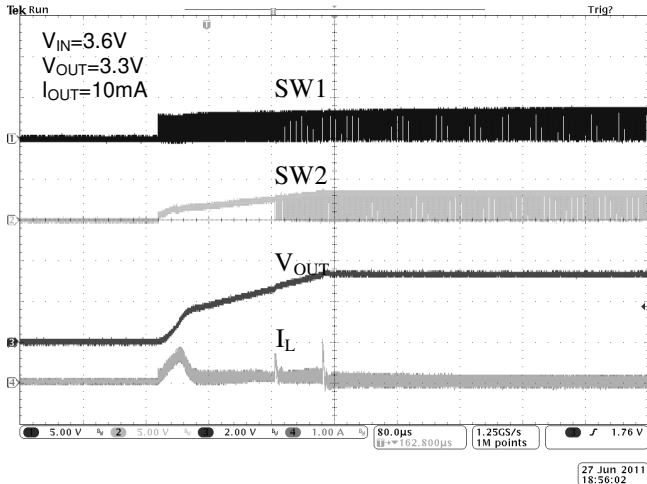

Fig.22 Power ON (PWM)

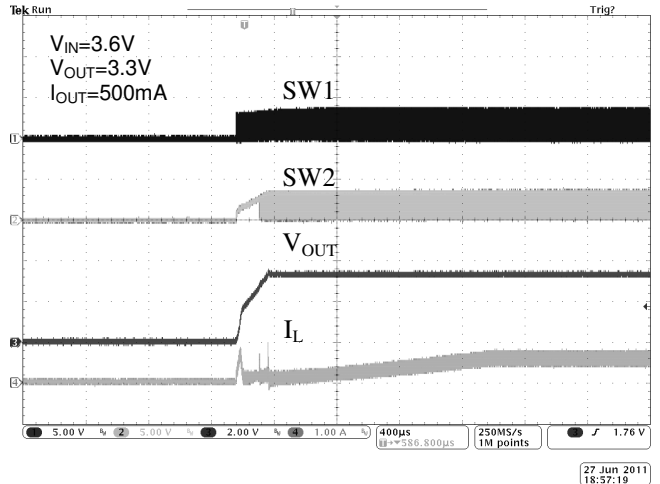

Fig.23 Power ON (PWM)

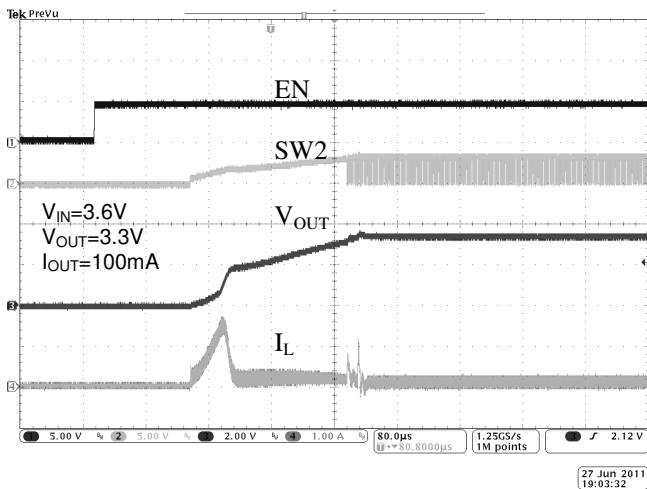

Fig.24 Start-up (PWM)

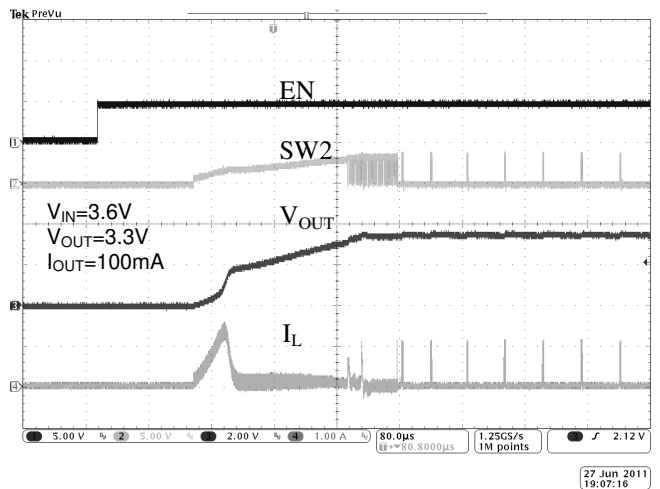

Fig.25 Start-up (PSM)

■ APPLICATION INFORMATION

Operation

The buck-boost DC-DC converter operates in a synchronous current mode with a low-noise effect, which obtains the good regulation of output voltage from different input voltages. When the input voltage is higher than the output voltage, the synchronous switches PMOS1 and NMOS1 construct the step-down mode (Buck) while the PMOS2 is always turned on and the NMOS2 is always turned off. When the input voltage is lower than the output voltage, the synchronous switches PMOS2 and NMOS2 construct the step-up mode (Boost) while the PMOS1 is always turned on and the NMOS1 is always turned off. When the input voltage approaches the output voltage, the device can automatically operate at Buck-Boost mode.

Enable

The device can be enabled when the voltage at EN pin is higher than 1.2V. It can go into the shutdown mode when the voltage at EN pin is lower than 0.4V. In shutdown mode, the PMOS1 and PMOS2 are switched off and the NMOS1 and NMOS2 are turned on.

Power Saving Mode and Synchronization

The AIC2341 can work at three different operation modes: the power saving mode, the forced fixed frequency mode and the external synchronization mode. When the voltage at MODE pin is low level, the AIC2341 can enter the power saving mode (PSM) at light load condition. The PSM can improve the efficiency at light load condition. When the voltage at MODE pin is high level, the AIC2341 can work at forced fixed frequency mode for all load conditions. Besides, by applying a 2.2MHz to 2.8MHz clock signal to the MODE pin, the AIC2341 internal oscillator frequency can be synchronized to the external clock.

Soft Start

The AIC2341 provides the soft start function to avoid the overshoot of output voltage. During start-

up period, an internal voltage ramp will clamp the rising slope of output voltage. In order to avoid the inrush current during the start-up process, the output capacitance value should be considered.

Current Limit

The AIC2341 provides current limit function to limit the output power to protect the internal power switches. When the peak inductor current reaches 1.8A, the PMOS1 and the PMOS2 would be turned off.

Inductor Selection

The component value of inductor and inductor current ripple are dependent. The calculation of inductance value uses the maximum input voltage in Buck mode and the minimum input voltage in Boost mode. The recommended minimum inductance value is greater than both of $L(Buck)$ and $L(Boost)$.

$$L(Buck) \geq D \cdot \frac{(V_{IN_MAX} - V_{OUT})}{f_{SW} \cdot \Delta I_L}, \quad D = \frac{V_{OUT}}{V_{IN_MAX}}$$

$$L(Boost) \geq D \cdot \frac{V_{IN_MIN}}{f_{SW} \cdot \Delta I_L}, \quad D = \frac{V_{OUT} - V_{IN_MIN}}{V_{OUT}}$$

where the switching frequency f_{SW} is 2.5MHz (Typically). The ΔI_L is inductor current ripple and the D is duty cycle.

The efficiency of ferrite core is well. The saturation current of the inductor core must be higher than both of $I_{peak}(Buck)$ and $I_{peak}(Boost)$. If the output current is fixed, the maximum peak current of inductor will appear while the AIC2341 works at the boost mode.

$$I_{peak}(Buck) = 1.25 \cdot I_{OUT} + \frac{\Delta I_L}{2}$$

$$I_{peak}(Boost) = 1.25 \cdot I_{OUT} \cdot \frac{V_{OUT}}{V_{IN}} + \frac{\Delta I_L}{2}$$

Capacitor Selection

The input capacitor should be put as close as possible to input terminal to avoid noise. The

recommend input capacitor is the 10μF X5R/X7R ceramic capacitor. For output capacitor, it's recommended to use low ESR ceramic capacitors. The output ripple voltage is given by

$$\Delta V_{OUT}(Buck) = D \cdot \frac{V_{IN_MAX} - V_{OUT}}{8 \cdot L \cdot C_{OUT} \cdot f_{SW}^2}, \quad D = \frac{V_{OUT}}{V_{IN_MAX}}$$

$$\Delta V_{OUT}(Boost) = D \cdot \frac{I_{OUT}}{C_{OUT} \cdot f_{SW}}, \quad D = \frac{V_{OUT} - V_{IN_MIN}}{V_{OUT}}$$

Output Voltage Programming

The AIC2341 has two versions: one is fixed output voltage version, and another is adjustable version. The external resistors R1 and R2 are connected between output, FB and GND for the adjustable

output voltage version. The reference voltage of the feedback loop is 500mV. The recommended value of the feedback resistor R2 is 10kΩ. R1 is given by

$$R1 = R2 \cdot \left(\frac{V_{OUT}}{V_{FB}} - 1 \right)$$

Layout Considerations

Placing the input capacitor, output capacitor and inductor as close to the AIC2341 as possible and using short traces. The feedback resistor should be placed as close to the IC as possible. In order to get better performance, the wide and short trace should be used for large current loop.

APPLICATION EXAMPLES

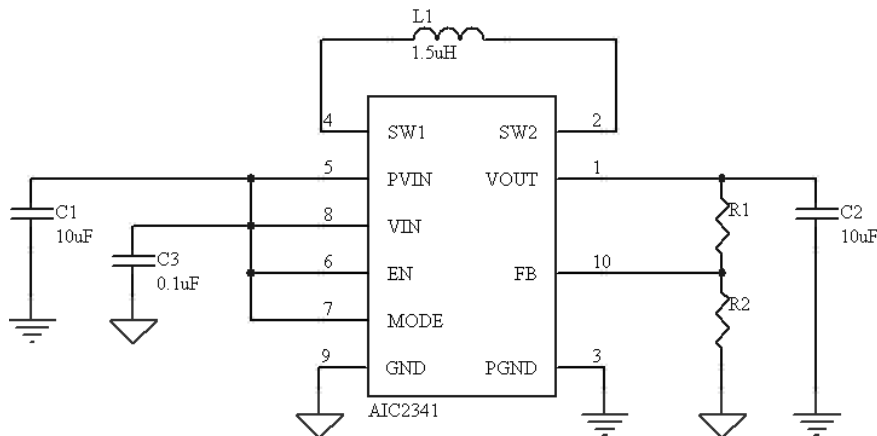
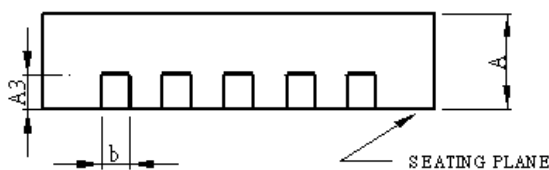
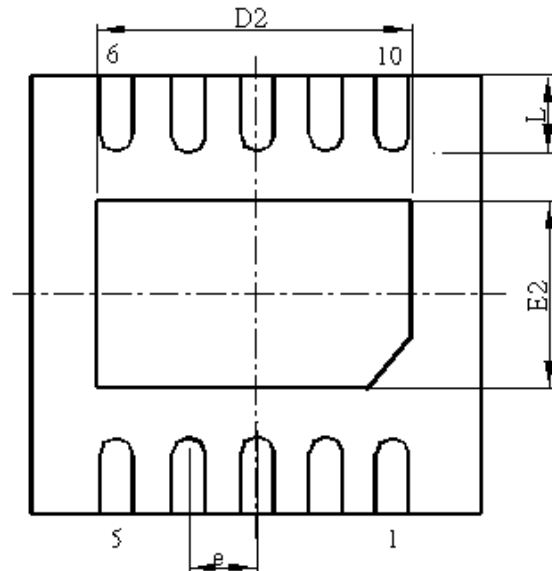
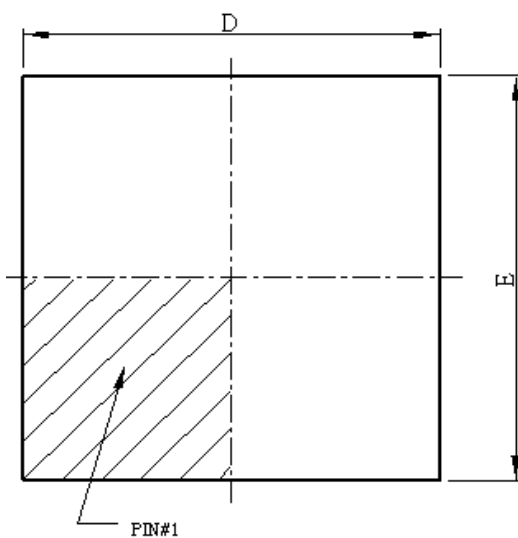

Fig.26 Adjustable Output Voltage

PHYSICAL DIMENSIONS (unit: mm)
DFN-10L-3X3

- Note :
1. Refer to JEDEC MS-012E.
 2. Dimension "D" does not include mold flash, protrusions or gate burrs. Mold flash, protrusion or gate burrs shall not exceed 6 mil per side .
 3. Dimension "E" does not include inter-lead flash or protrusions.
 4. Controlling dimension is millimeter, converted inch dimensions are not necessarily exact.

SYMBOL	DFN 10L-3x3x0.75-0.5mm	
	MILLIMETERS	
	MIN.	MAX.
A	0.70	0.80
A3	0.20 BSC	
b	0.18	0.30
D	2.90	3.10
D2	2.20	2.70
E	2.90	3.10
E2	1.40	1.80
e	0.5 BSC	
L	0.30	0.50

Note:

Information provided by AIC is believed to be accurate and reliable. However, we cannot assume responsibility for use of any circuitry other than circuitry entirely embodied in an AIC product; nor for any infringement of patents or other rights of third parties that may result from its use. We reserve the right to change the circuitry and specifications without notice.

Life Support Policy: AIC does not authorize any AIC product for use in life support devices and/or systems. Life support devices or systems are devices or systems which, (i) are intended for surgical implant into the body or (ii) support or sustain life, and whose failure to perform, when properly used in accordance with instructions for use provided in the labeling, can be reasonably expected to result in a significant injury to the user.