

DESCRIPTION FM76651

The FM76651 is a high-efficiency step-down controller. It is designed to operate in continuous current mode (CCM) to power LEDs of high-brightness with a wide input voltage range of 6V to 60V.

The FM76651 employs a hysteretic control architecture that accurately regulates LED current with a feedback coming from an external high-side current-sense resistor. This control scheme optimizes circuit stabilization and fast response time without loop compensation. Its low 200mV average feedback voltage reduces power loss and improves the converter's efficiency.

The FM76651 implements PWM and analog dimming together through the EN/DIM pin.

The FM76651 includes thermal overload protection in case of output overload.

The FM76651 is available in TSOT6 package.

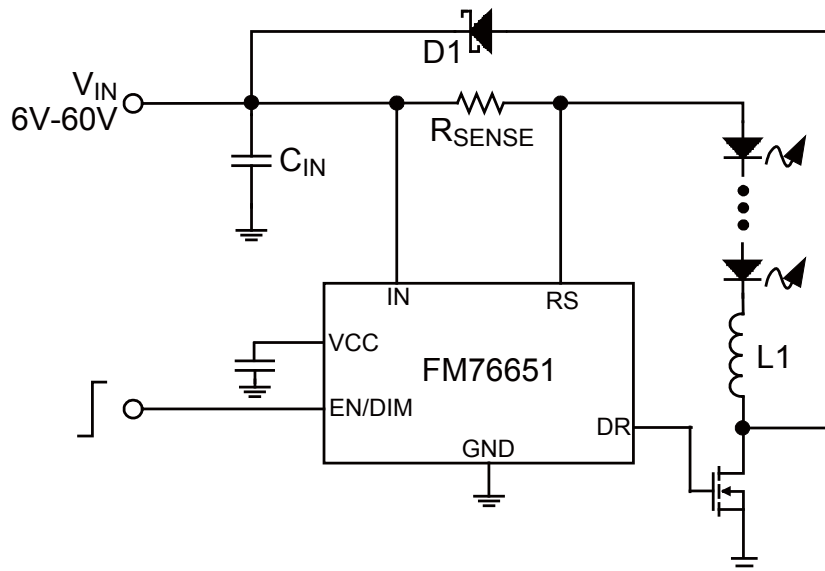
FEATURES

- Wide 6V to 60V Input Range
- Able to Drive >1A LED Load
- Hysteresis Control
- High Efficiency (>95%)
- 2500:1 PWM Dimming Ratio
- Open LED Protection
- Short LED Protection
- Thermal Shutdown

APPLICATIONS

- Low Voltage Halogen Replacement
- Low Voltage General Illumination
- Automotive/Decorative LED Lighting
- Signs/Emergency Lighting
- LED Backlighting

TYPICAL APPLICATION

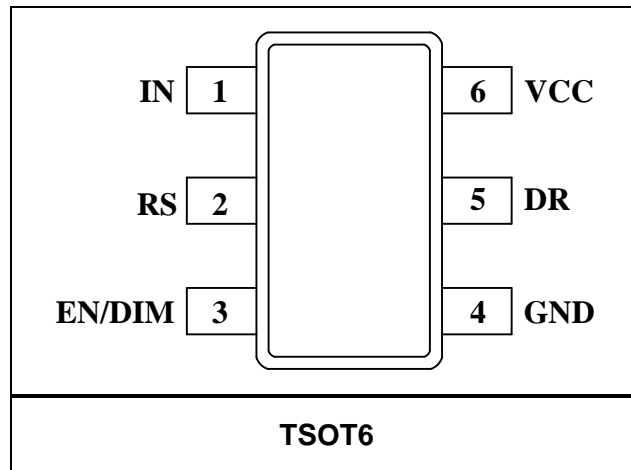


ORDERING INFORMATION

Part Number*	Package	Top Marking
FM76651D	TSOT6	1AYWW

YWW:Manufacturers of water code changes

PACKAGE REFERENCE



ABSOLUTE MAXIMUM RATINGS ⁽¹⁾

V _{IN}	-0.3V to +65V
V _{RS}	(V _{IN} - 5V) to V _{IN}
All Other Pins	-0.3V to +6.5V
Continuous Power Dissipation (T _A = 25°C) ⁽²⁾	
TSOT6	1.25W
Junction Temperature	150°C
Lead Temperature	260°C
Storage Temperature.....	-65°C to +150°C

Recommended Operating Conditions ⁽³⁾

Supply Voltage V _{IN}	6V to 60V
Operating Junction Temp. (T _J)	-40°C to +125°C

Thermal Resistance ⁽⁴⁾

	θ_{JA}	θ_{JC}
TSOT6	100	55 ... °C/W

Notes:

- 1) Exceeding these ratings may damage the device.
- 2) The maximum allowable power dissipation is a function of the maximum junction temperature T_J(MAX), the junction-to-ambient thermal resistance θ_{JA} , and the ambient temperature T_A. The maximum allowable continuous power dissipation at any ambient temperature is calculated by P_D(MAX)=(T_J(MAX)-T_A)/ θ_{JA} . Exceeding the maximum allowable power dissipation will cause excessive die temperature, and the regulator will go into thermal shutdown. Internal thermal shutdown circuitry protects the device from permanent damage.
- 3) The device is not guaranteed to function outside of its operation conditions.
- 4) Measured on JESD51-7, 4-layer PCB.

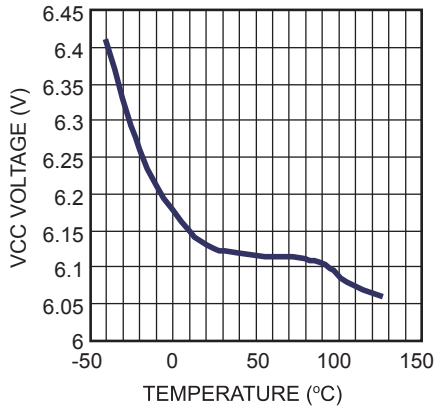
ELECTRICAL CHARACTERISTICS

$V_{IN} = 24V$, $T_A = 25^{\circ}C$, unless otherwise noted.

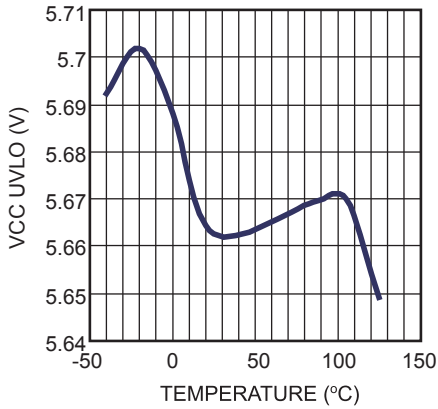
Parameter	Symbol	Condition	Min	Typ	Max	Units
Input voltage	V_{IN}		6		60	V
Shutdown supply current	I_{SD}			80	108	μA
Quiescent supply current	I_Q	No Switching		0.3	0.5	mA
VCC voltage	VCC	$V_{EN/DIM} = 3.5V$	5.5	6		V
Feedback average voltage (with respect to V_{IN})	$V_{IN}-V_{RS}$	$V_{EN/DIM} = 3.5V$	194	200	206	mV
Feedback reference voltage hysteresis	V_{FB_HYS}			± 30		mV
EN/DIM enable high voltage	V_{EN_HIGH}	V_{EN} Rising		0.29	0.34	V
EN/DIM enable hysteresis	V_{EN_HYS}		20	50	80	mV
EN/DIM pull-up current		Pull up to 5V		2.8		μA
EN/DIM pull-down current		Pull down to GND		25		μA
Min recommended pwm dimming frequency	F_{PWMmin}			0.1		kHz
Max recommended pwm dimming frequency	F_{PWMmax}			20		kHz
Gate driver source resistor	R_{source}	$V_{GS} = 5.5V$		6		Ω
Gate driver sink resistor	R_{sink}			2		Ω
Gate driver output-voltage high	V_{OH}	$I_{DRV} = 10mA$	5.5			V
Gate driver output-voltage low	V_{OL}	$I_{DRV} = 10mA$			0.5	V
Minimum on time	T_{ON_MIN}	Guarantee by Designer		100		ns
Minimum off time	T_{OFF_MIN}	Guarantee by Designer		100		ns
Recommended maximum operating frequency	F_{MAX}			1		MHz
UVLO threshold voltage(VCC)	V_{UVLOTH}	VCC Rising		5.6		V
UVLO hysteresis	$V_{UVLOHYS}$			0.4		V
Thermal shutdown threshold		Temp Rising		150		$^{\circ}C$
Thermal shutdown hysteresis		Guarantee by Designer		20		$^{\circ}C$

TYPICAL CHARACTERISTICS

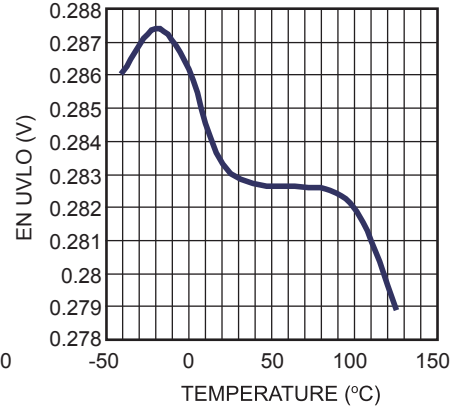
VCC Voltage vs. Temperature



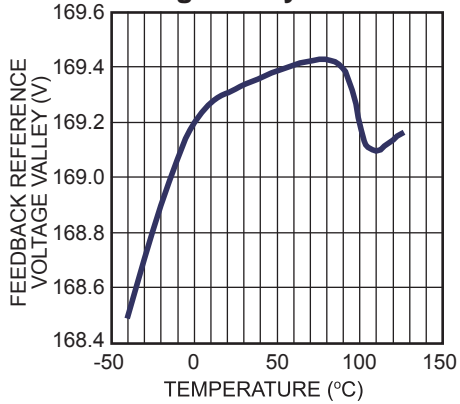
VCC UVLO vs. Temperature



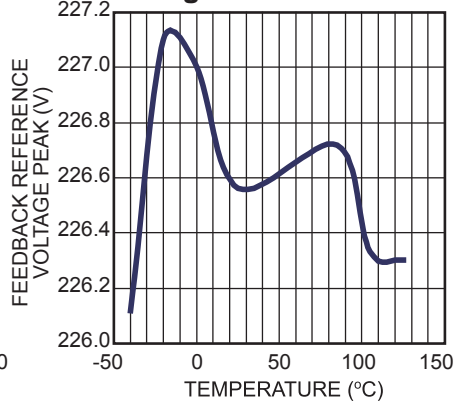
EN UVLO vs. Temperature



Feedback Reference Voltage Valley



Feedback Reference Voltage Peak

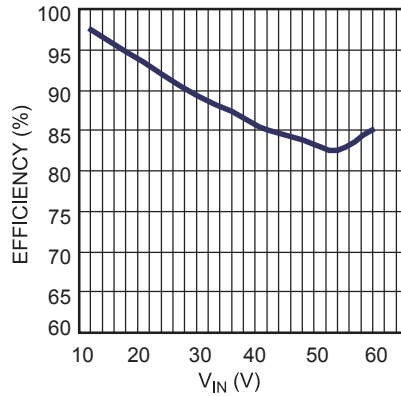


TYPICAL PERFORMANCE CHARACTERISTICS

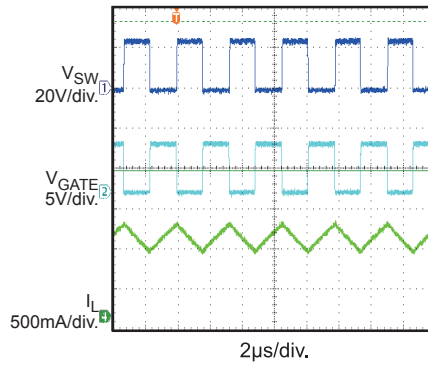
Performance waveforms are tested on the evaluation board of the Design Example section.

$V_{IN} = 24V$, 3LEDs, $I_{OUT} = 1A$, $T_A = 25^\circ C$, unless otherwise noted.

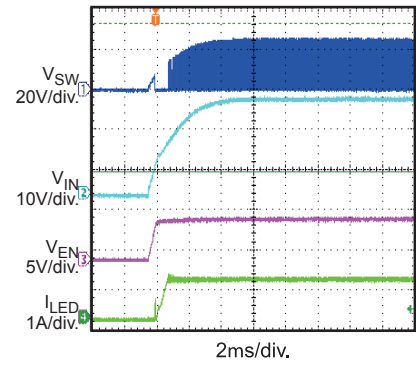
Efficiency



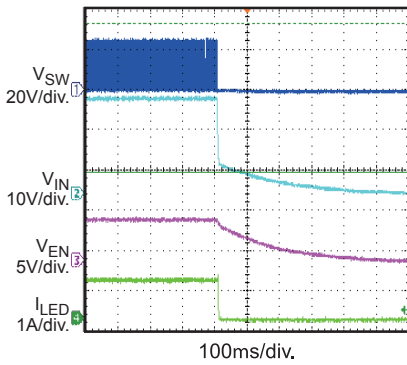
Steady State



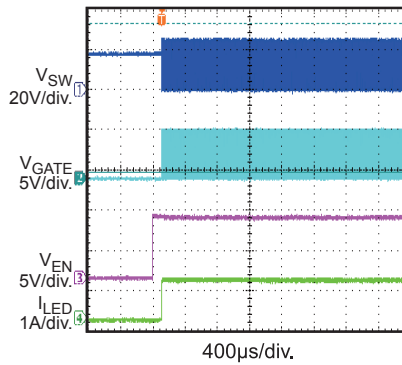
Input Power On



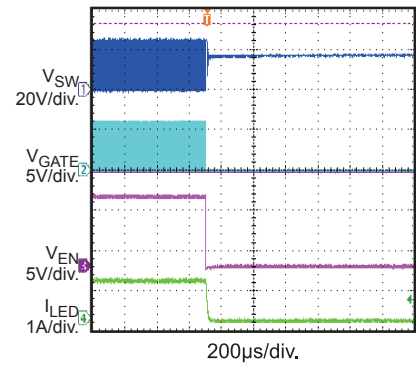
Input Power Off



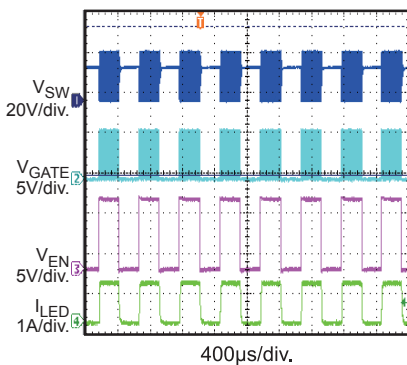
EN Power On



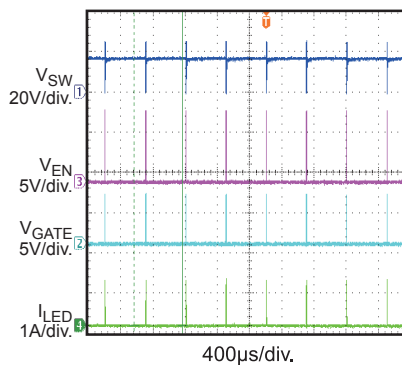
EN Power Off



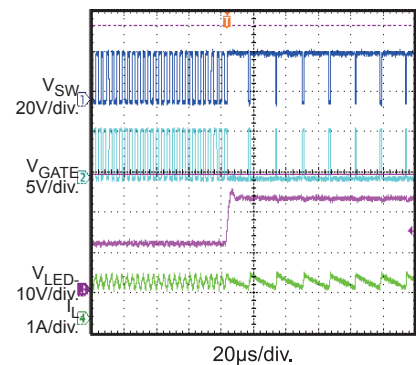
**PWM Dimming
(2kHz, 50%)**



**PWM Dimming
(2kHz, 1%)**



**Short LED+ to
LED- Protection**

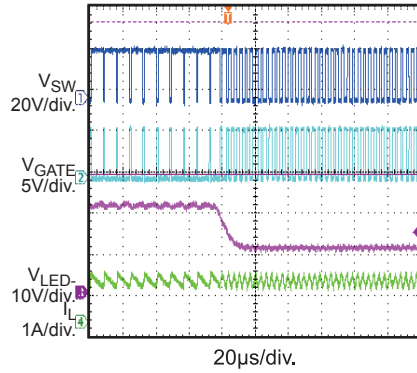


TYPICAL PERFORMANCE CHARACTERISTICS *(continued)*

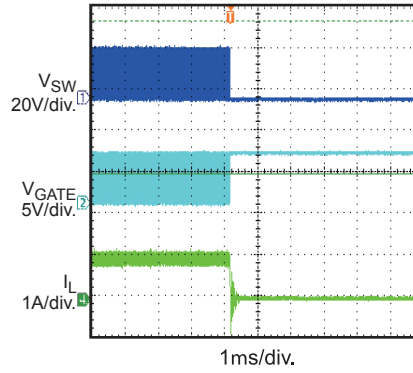
Performance waveforms are tested on the evaluation board of the Design Example section.

$V_{IN} = 24V$, 3LEDs, $I_{OUT} = 1A$, $T_A = 25^\circ C$, unless otherwise noted.

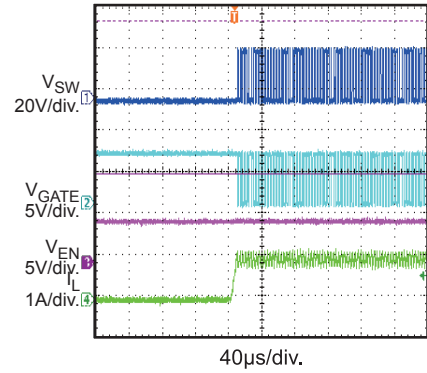
Short LED+ to LED- Recovery



Open LED Load Protection



Open LED Load Recovery



PIN FUNCTIONS

TSOT6 Pin#	Name	Description
1	IN	Input Supply Pin. Connect a decoupling capacitor from IN pin to GND.
2	RS	LED Current Sense Input. Connect a current-sense resistor that programs LED average current to the IN pin.
3	EN/DIM	Enable/Dimming Command Input. A voltage greater than 0.3V turns on the chip. To use PWM dimming, apply a square wave signal to this pin. If dimming-off time is larger than 20ms, the IC shuts down. For analog dimming, the EN/DIM pin voltage rises from 0.3V to 2.7V and LED current will change from 20% to 100% of the maximum LED current.
4	GND	Ground.
5	DR	Gate-Driver Output. Connect this pin to the gate of the external MOSFET.
6	VCC	Internal Regulator Output. Connect a 1 μ F decoupling cap from this pin to ground.

FUNCTIONAL BLOCK DIAGRAM

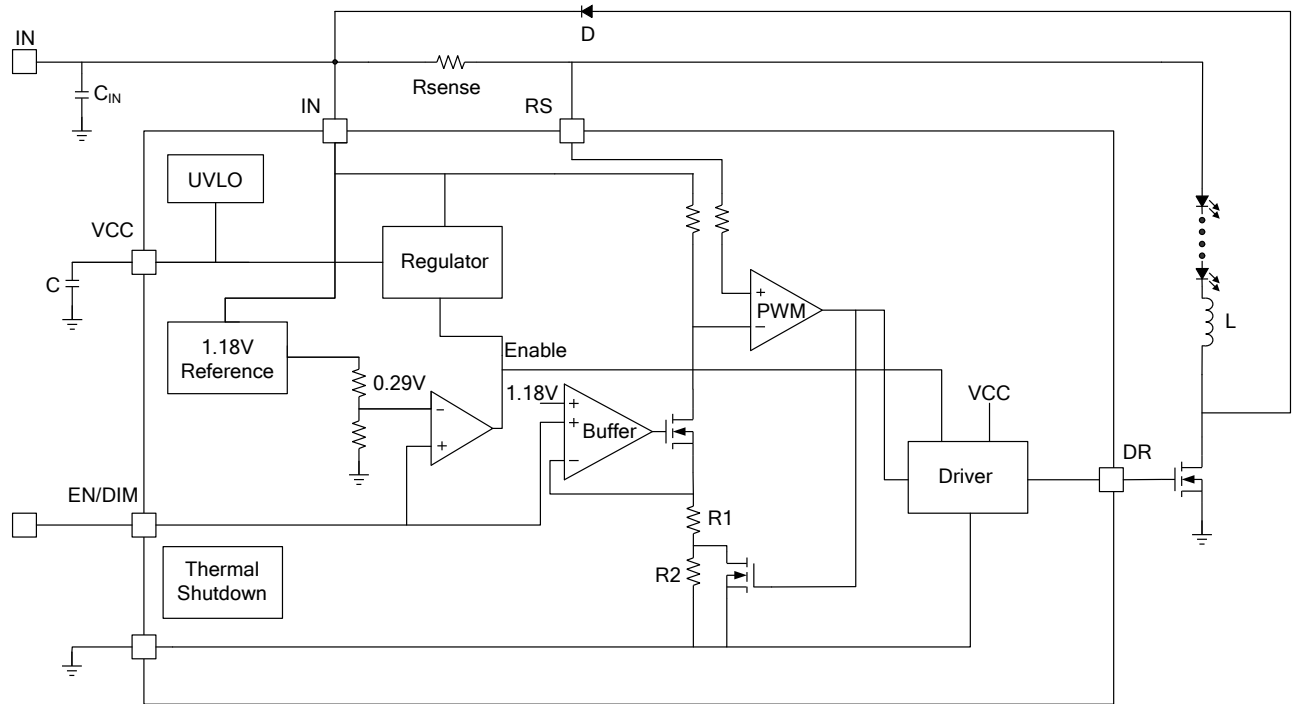


Figure 1—FM76651 Functional Block Diagram

OPERATION

Steady State

The FM76651 is a step-down LED-current controller with hysteresis control that is easily configured for a wide input that ranges from 6V to 60V input. The FM76651 uses a high-side current-sense resistor to detect and regulate LED current. The voltage across the current-sense resistor is measured and regulated in the 200mV±30mV range.

The internal 1.18V reference voltage provides a 0.3V reference to enable the part. When $V_{EN} > 0.3V$, the output of the comparator goes high and enables the other blocks. The FM76651 also provides a 5V pull-up voltage as current reference voltage when EN/DIM pin is float.

The inductor current is sensed through the high-side resistor, R_{sense} . When the switch is on, R2 (see Figure 1) is shorted and inductor current upper-threshold is fixed by R1. When the switch is off, inductor current lower-threshold is fixed by R1 and R2. The ratio of R1 and R2 determines the current hysteresis.

System Soft Start

The voltage on the EN/DIM pin provides the inductor current reference. An external capacitor from the EN/DIM pin to ground provides a soft-start delay. When V_{IN} starts, internal voltage source charges the capacitor from 0V to 5V to fulfill soft-start function.

Dimming Control

The FM76651 allows the EN/DIM pin to control both Analog and PWM dimming. Whenever the voltage on DIM is less than 0.25V, the chip turns off. For analog dimming, when the voltage on DIM is from 0.3V to 2.7V, the LED current will change from 20% to 100% of the maximum LED current. If the voltage on EN pin is higher than 2.9V, output LED current will equal the maximum LED current. For PWM dimming, the signal amplitude must exceed 3V. Choose a PWM frequency in range of 100Hz to 20kHz for good dimming linearity.

APPLICATION INFORMATION

Setting the LED Current

The LED current is identical and set by the current sense resistor between the IN pin and RS pin.

$$R_{\text{SENSE}} = 200\text{mV}/I_{\text{LED}}$$

For $R_{\text{SENSE}} = 0.2\Omega$, the LED current is set to 1A

Selecting the Inductor

Lower value of inductance can result in a higher switching frequency, which causes a larger switching loss. Choose a switch frequency between 100kHz to 600kHz for most application. According to switching frequency, inductor value can be estimated as:

$$L = \frac{\left(1 - \frac{V_{\text{OUT}}}{V_{\text{IN}}}\right) \times V_{\text{OUT}}}{0.3 \times I_{\text{LED}} \times f_{\text{SW}}}$$

For higher efficiency, choose an inductor with a DC resistance as small as possible.

Selecting the Input Capacitor

The input capacitor reduces the surge current drawn from the input supply and the switching noise from the device. Choose a capacitor value between 10 μ F and 22 μ F for most applications. The voltage rating should be greater than the input voltage. Use a low ESR capacitor for input decoupling.

Selecting the Output Capacitor

For most applications, the output capacitor is not necessary. For applications that require that the peak-to-peak LED ripple current falls below 30% of the average current, add a capacitor across the LEDs. Higher capacitor values will result in proportionally lower ripple. A value of 2.2 μ F will meet most requirements.

Selecting Soft-Start Capacitor

When selecting a soft-start capacitor, the delay time can be estimated as 0.2ms/nF. For PWM dimming, select $C < 2.2\text{nF}$ to eliminate its effect on the average LED current.

Dimming Control

FM76651 provides 1:2500 high-ratio PWM dimming. Apply a 100Hz to 20kHz square waveform to the EN/DIM pin. The average LED current is proportional to PWM duty cycle.

Layout Consideration

Pay careful attention to the PCB layout and component placement. R_{SENSE} should be placed close to the IN pin and RS pin in order to minimize current sense error. The input loop—including input capacitor, Schottky diode, and Mosfet—should be as short as possible.

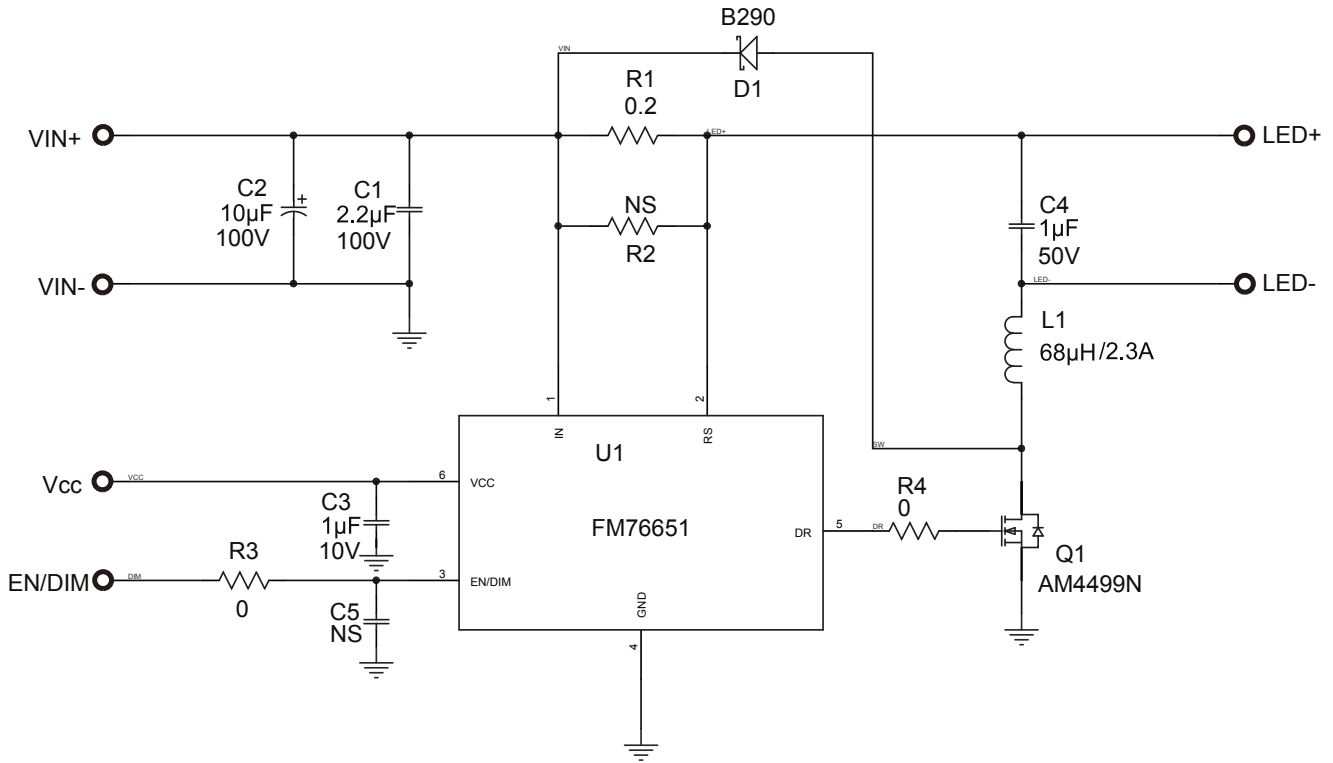
Design Example

Below is a design example following the application guidelines for the specifications:

Table 1: Design Example

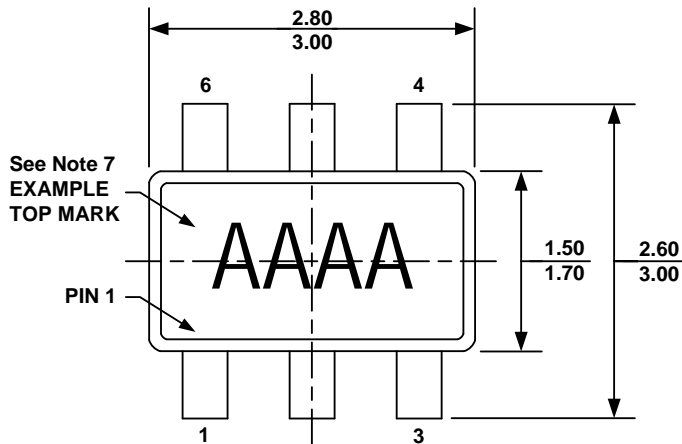
V_{IN}	24V
V_{OUT}	10V
I_{out}	1A

The detailed application schematic is shown in Figure 2. The typical performance and circuit waveforms have been shown in the Typical Performance Characteristics section. For more device applications, please refer to the related Evaluation Board Datasheets.

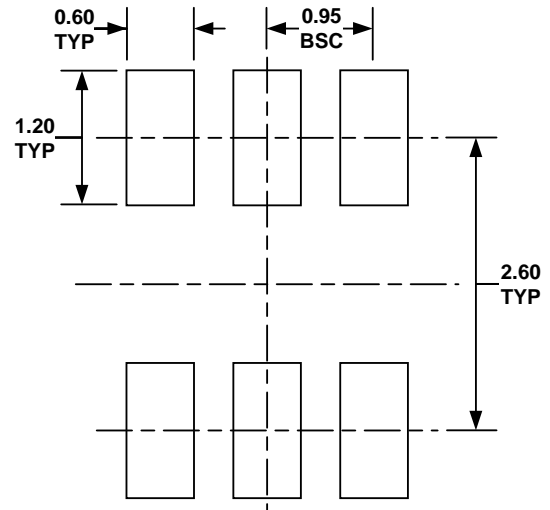

Figure 2: Application Circuit

PACKAGE INFORMATION

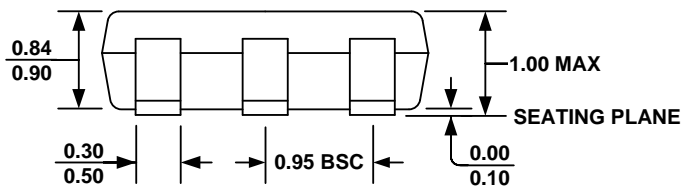
TSOT6



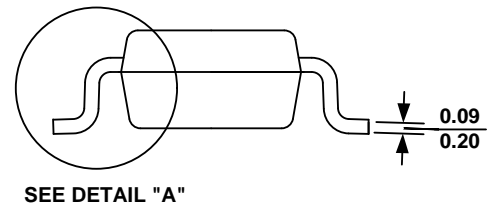
TOP VIEW



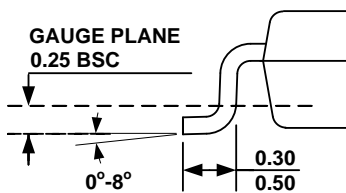
RECOMMENDED LAND PATTERN



FRONT VIEW



SIDE VIEW



DETAIL "A"

NOTE:

- 1) ALL DIMENSIONS ARE IN MILLIMETERS.
- 2) PACKAGE LENGTH DOES NOT INCLUDE MOLD FLASH, PROTRUSION OR GATE BURR.
- 3) PACKAGE WIDTH DOES NOT INCLUDE INTERLEAD FLASH OR PROTRUSION.
- 4) LEAD COPLANARITY (BOTTOM OF LEADS AFTER FORMING) SHALL BE 0.10 MILLIMETERS MAX.
- 5) DRAWING CONFORMS TO JEDEC MO-193, VARIATION AB.
- 6) DRAWING IS NOT TO SCALE.
- 7) PIN 1 IS LOWER LEFT PIN WHEN READING TOP MARK FROM LEFT TO RIGHT, (SEE EXAMPLE TOP MARK)