



General Description

AP2359 is a current mode PWM power switch IC. It combines a current mode PWM controller and a power MOSFET. It is optimized for high performance off-line flyback converter application in sub 24 W range. For lower the standby power and higher RoHS compliant, the IC offers a Burst Mode control feature and ultra-low start-up current and operating current, that is, at the condition of no load or light load, AP2359 can reduce the switch frequency linearly which minimize the switching power loss; the ultra-low startup current and operating current make a reliable power for startup design, and also large resistor can be used in the startup circuit to improve switching efficiency. The internal synchronous slope compensation circuit reduces the possible subharmonic oscillation at high PWM duty cycle output. Leading-edge blanking on current sense (CS) input removes the signal glitch due to snubber diode circuit reverse recovery and thus greatly reduces the external component count and system cost in the design. AP2359 offers comprehensive protection coverage with automatic self-recovery feature, including cycle by cycle over current protection (OCP), over load protection (OLP), under voltage lockout (UVLO). The gate-driven output is clamped to maximum 18V to protect the internal MOSFET.

Excellent EMI performance is achieved by using the frequency jittering at the totem-pole-gate-drive output. The tone energy at below 20KHZ is minimized in the design and audio noise is eliminated during operation. The AP2359 is the ideal substitute of the linear power supply, for a better

performance of the whole switch power system and a lower cost. AP2359 is available in DIP-8 package.

Features

- ▼ Burst Mode control
- ▼ 4uA ultra-low startup current
- ▼ 1.4mA Low operating current
- ▼ Built-in Leading-edge blanking
- ▼ Built-in synchronous slope compensation circuit
- ▼ Current Mode operates
- ▼ Fixed frequency 65kHz
- ▼ Cycle by cycle over current protection (OCP)
- ▼ VDD over voltage clamp & under voltage lockout (UVLO)
- ▼ Maximum Gate-driven output voltage clamped at 18V
- ▼ Frequency jittering
- ▼ Constant limited output power
- ▼ Over load protection (OLP)
- ▼ Free audio noise operation
- ▼ Build in high voltage power MOSFET

Applications

Universal switch power supply equipment and offline AC/DC flyback power converter

Power Adapter STB

Power Supplies

Open-frame SMPS

Battery Charger





Typical Application Circuit

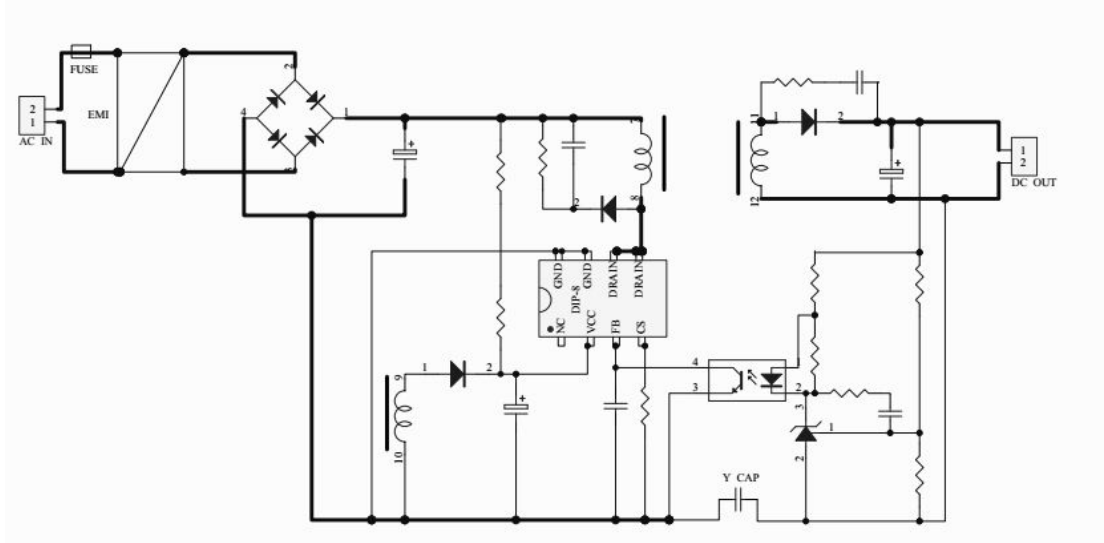

Output table

Product	230VAC±15%	85-265VAC
AP2359	Open Frame1	Open Frame1
	24W	18W

Note1:Maximum practical continuous power in an open frame design with sufficient drain pattern as a heat sink,at 50°C





Pin Definition and Device Marking

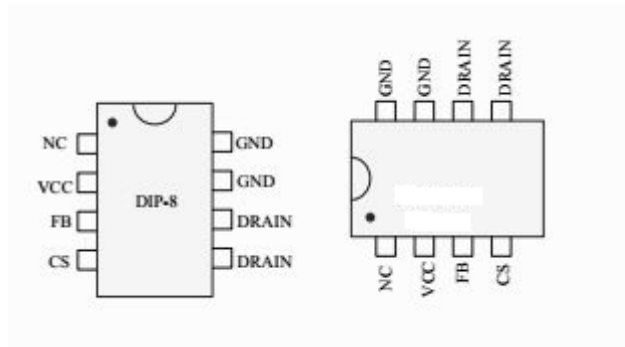

Pin function description

Pin name	Pin number	Pin type	Function description
NC	1	NC	NC
VDD	2	Power	Power Supply
FB	3	Feedback Input	Feedback Input Pin. The PWM duty cycle is determined by this pin voltage level and current-sense signal at Pin 4. The internal circuit will automatically shutdown when the FB voltage level exceeds a present threshold voltage.
CS	4	Current Monitoring	Current Sensing
Drain	5,6	Internal MOSFET Drain	Internal HV MOSFET Drain. Connected to the primary lead of the transformer
GND	7,8	GND	ground





AP2359

Current Mode PWM Controller

Block Diagram

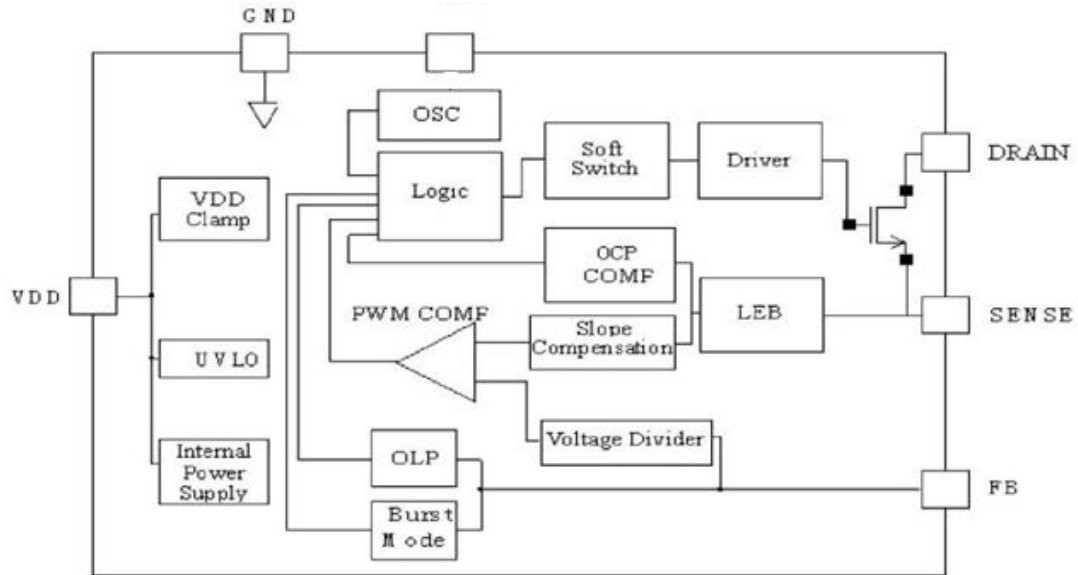



Absolute maximum ratings

Symbol	Parameter	Value	Unit
Drain voltage(off-state)	Internal HV MOS Drain voltage	-0.3~650	V
VDD	DC supply voltage	30	V
VFB	FB Input Voltage	-0.3~7	V
VCS	Current-sense Input Voltage	-0.3~7	V
Tj	Operating Junction Temperature	-20~150	°C
Tstg	Storage Temperature	-40~150	°C
Vev	VDD Clamp Voltage	34	V
Icc	VDD DC Clamp Current	10	mA

Note: Stresses above those list under absolute maximum ratings may cause permanents damage to the device., These are stress ratings only. functional operation of the device at these or any other conditions beyond those indicated in the recommended operating conditions section are not implied. Exposure to absolutely maximum-rated conditions for extended periods may affects device reliability.

Recommended operating condition

Symbol	Parameter	Value	Unit
VDD	VDD supply voltage	10.5~25	V
Tj	Operating temperature	-20~80	°C

ESD information

Symbol	Parameter	Value	Unit
Vesd-HBD	Human Model	3	KV
Vesd-MM	Machine Model	150	V





AP2359

Current Mode PWM Controller

Electrical characteristics

VDD						
Symbol	Parameter	Test Condition	MIN	Type	MAX	Unit
VDD-Op	Operation Voltage		11		26	V
UVLO-On	Turn-Off threshold		6.8		10.5	V
UVLO-Off	Turn-on threshold		13		16.5	V
I_VDD-ST	Start-up Current	VDD=12V		3		uA
I_VDD-Op	Operation Current	VDD=16V;FB=2.0V		1.5		mA
VDD-Clamp	VDD Zener Clamp Voltage	I_Vdd=10mA				V
FB						
VFB_Open	V_FB Open Loop Voltage			5.7		V
IFB_Short	FB Pin Short Current	FB Shorted to GND	0.75	0.865	0.98	mA
VTH_PL	Power limiting FB Threshold			3.0		V
TD_PL	Power limiting Debounce			65		ms
ZFB_IN	Input Impedance			20		kΩ
Max_Duty	Maximum duty cycle			75		%
CS						
TLEB	Leading edge Blanking Time			1200		ns
Zsense	Input impedance			40		kΩ
TD_OC	OCP control delay			120		ns
VTH_OC	OCP threshold			0.7		V
Oscillator Section						
Fosc	Frequency	Oscillation	50	65	80	khz
Fosc_BM	Burst mode frequency			25		khz
HV MOSFET						
BVdss	breakdown voltage		650			V
Ron	Static Drain to Source on resistance				2.2	Ω





Typical Operating Characteristics

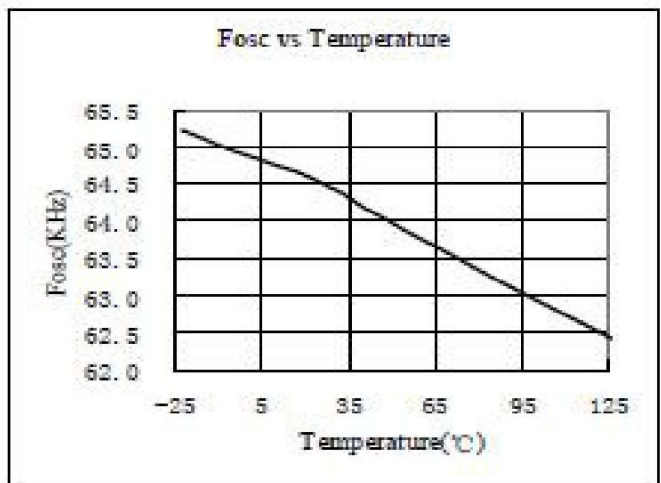
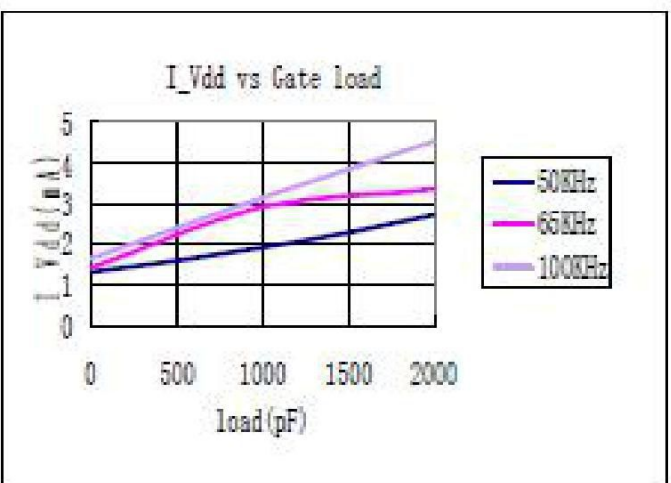
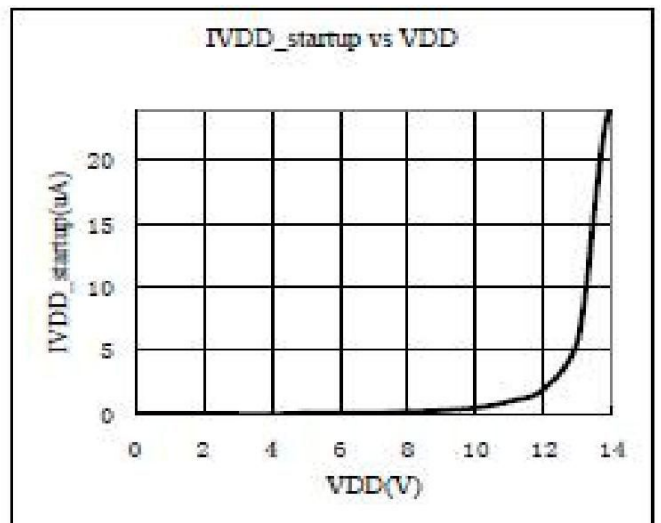
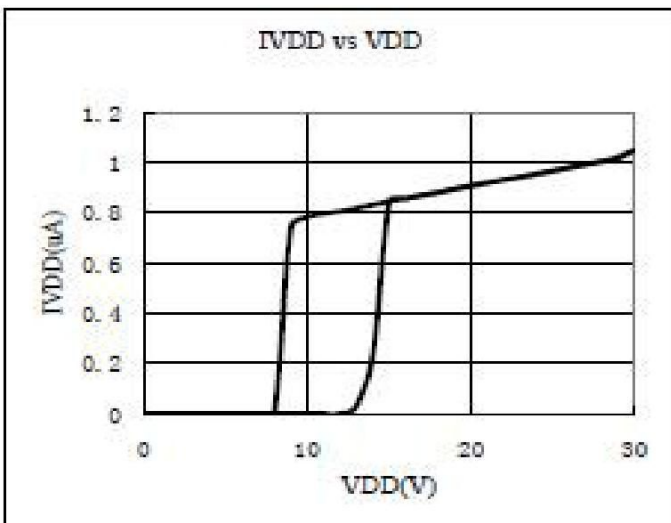
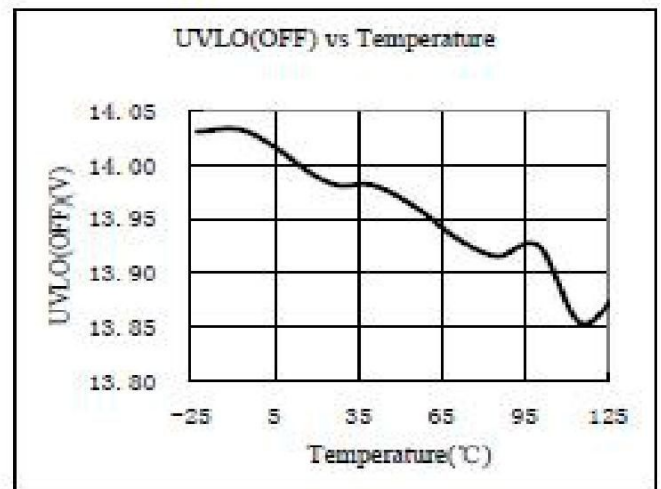
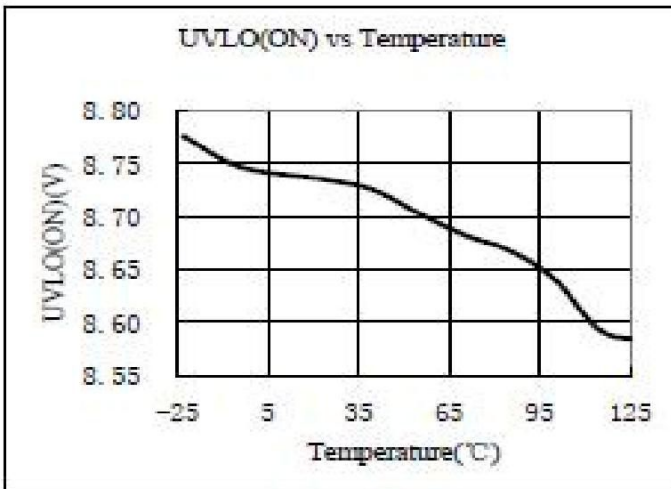



Function Description

AP2359 combines a dedicated current mode PWM controller with a high voltage power MOSFET. It is optimized for high performance off-line flyback converter application in sub 18W range. Ultra low startup current and operating current together with burst mode feature minimize the standby power consumption and improve the switching efficiency. In addition to reduce the external component count, the internal synchronous slope compensation combines with the leading-edge blanking improves system large stability and reduce. The possible subharmonic oscillation. AP2359 also have multiform general recovery protection mode. The main function is described as below.

Start-up current and start-up control

Startup current of AP2359 is designed to be extremely low at 3uA, so that VDD could be charged up above UVLO threshold level and device starts up quickly. A large value startup resistor can therefore be used to minimize the power loss, predigest the design of startup circuit and provides reliable startup in application. For the design of

AC/DC adaptor with universal input range, a startup resistor of 2 MΩ, 1/8 W could be used together with a VDD capacitor to provide a fast startup and low power dissipation solution.

Operation Current

The operating current of AP2359 is low at 1.5mA. Excellent efficiency is achieved with low operating current together and extended burst mode control circuit.

Extended Burst mode

Operation

At zero load or light load, most of the power dissipation of the switching power supply comes from the MOSFET switching loss, the core loss of the transformer and the loss on the snubber circuit. The magnitude of power loss is in proportion to the number of switching events within a period of time. Therefore reducing the switch event leads to reduction on the power loss and thus saving the energy. For the burst mode control circuit, AP2359 self adjusts the switching mode according to the loading condition. At the condition of no load or light/medium load, the FB input voltage drops below burst mode threshold level. Device enters Burst





AP2359

Current Mode PWM Controller

Mode control on the basis of the judgment. The gate drive output switches only when VDD voltage drops below a preset level and FB input is active. Otherwise the gate drive remains at off to minimize the switching loss and power consumption to the greatest extent. The frequency control also eliminates the audio noise at any loading conditions.

Internal Synchronized Slope

Compensation

Built-in slope compensation circuit adds slope voltage onto the current sense input voltage for PWM generation. This greatly enhances the close loop stability at CCM and prevents possible subharmonic

oscillation and thus reduces the output ripple voltage.

Protection Control

Excellent system stability is achieved by the comprehensive protection of AP2359 Including Cycle-by-Cycle current limiting (OCP), Over Load Protection (OLP) and over voltage clamp, Under Voltage Lockout on VDD (UVLO). The average of the PWM signal is detected by the built-in OCP protection circuit effectively. At overload condition when FB input voltage exceeds power limit threshold value for more than TD_PL, control circuit reacts to shut down the output power MOSFET. Device restarts when VDD voltage drops below UVLO limit. It is clamped when VDD is higher than threshold value. The power MOSFET is shut down when VDD drops below UVLO limit and device enters power on start-up sequence thereafter.





AP2359

Current Mode PWM Controller

Package Information

8 PIN Plastic DIP

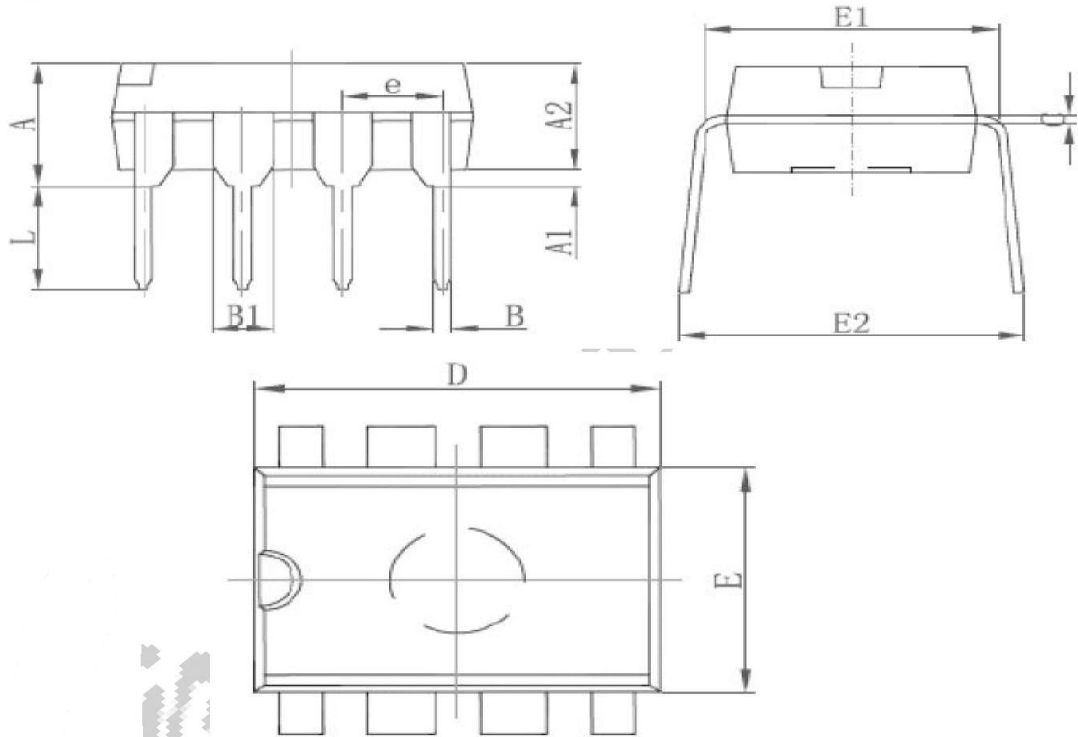

Symbol	Dimensions In Millimeters		Dimensions In Inches	
	Min	Max	Min	Max
A	3.710	4.310	0.146	0.170
A1	0.500		0.020	
A2	3.200	3.600	0.126	0.142
B	0.350	0.650	0.014	0.026
B1	1.524(BSC)		0.060(BSC)	
C	0.204	0.360	0.008	0.014
D	9.000	9.500	0.354	0.374
E	6.200	6.600	0.244	0.260
E1	7.320	7.920	0.288	0.312
e	2.540(BSC)		0.100(BSC)	
L	3.000	3.600	0.118	0.142
E2	8.200	9.000	0.323	0.354

