

QC3.0 & NT6008 Introduction

2015/10/06



EOSMEM Confidential, Prepared for

QC3.0 vs. QC2.0

- QC3.0 defines continuous mode as $D+ = 0.6$, $D- = 3.3V$
- Output voltage increases/decreases 200mV upon each $D+/D-$ toggle
- Output voltage range: 3.6V ~ 20V (12V for class A)

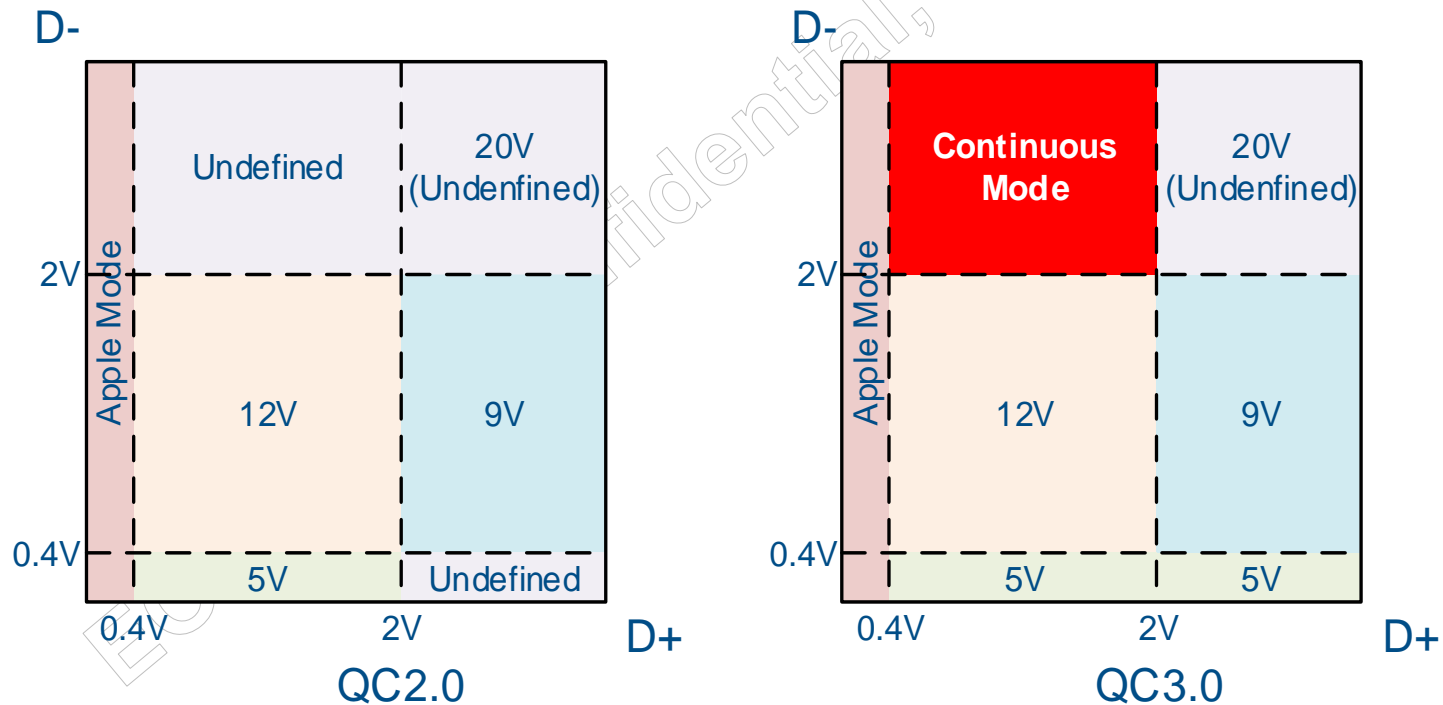

Output Voltage Increment/Decrement

- $D+ > 2.0V$ pulse increases output voltage by 200mV
- $D- < 2.0V$ pulse decreases output voltage by 200mV
- Pulses $< 150\mu s$ will be skipped
- Once entering QC3.0, stay at QC3.0 unless $D+ \text{ or } D- < 0.4V$

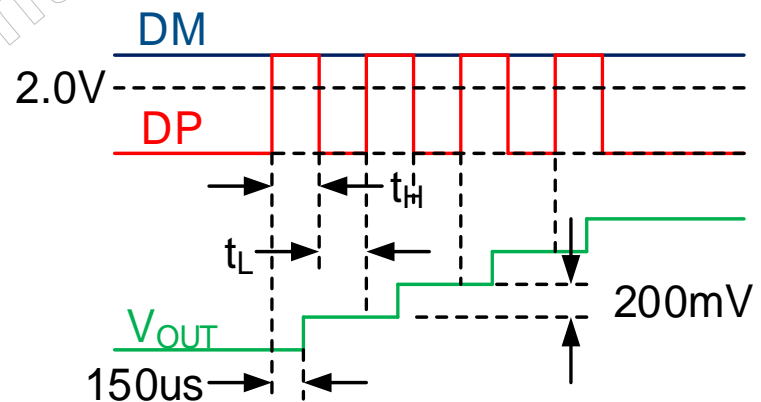
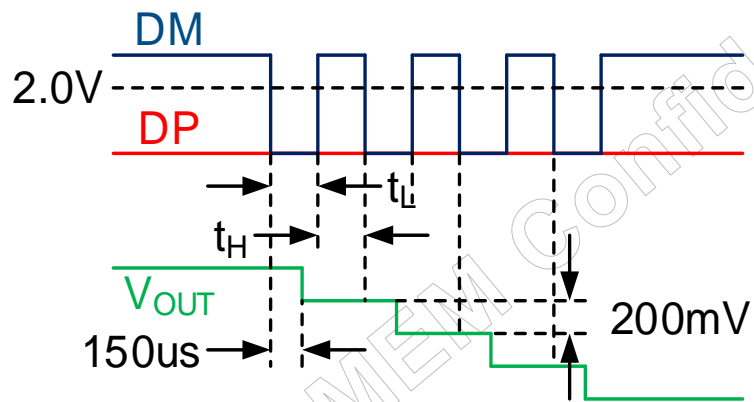

Application Circuit

- OUT pin sinks/sources current to adjust output voltage of HVDCP according to QC2.0/3.0 protocol
- MSOP-10L easy to co-layout with other QC2.0 parts

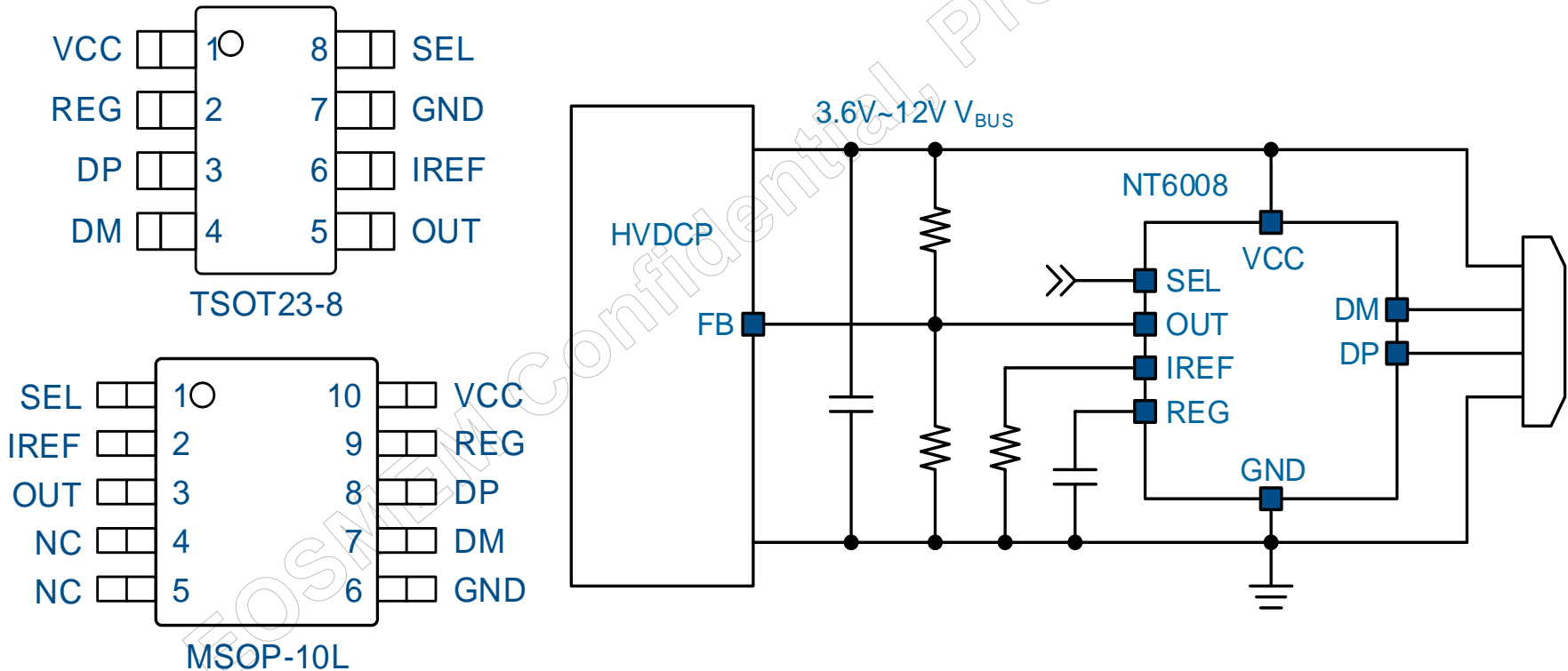

Features

- **3.3V ~ 13.5V Single Supply Operation**
- **Smart USB Charger Identification Circuit**
 - **Compliant with QC2.0/3.0 Class A**
 - **Selectable Apple iPad 2.4A/2.1A Applications**
 - **Support Samsung Galaxy Note 2.0A Applications**
 - **Support BC1.2 & YD/T 1591 Battery Charging Specifications**
- **8kV High ESD**
- **Smooth Voltage Transition**
- **OVP Protection**
- **Discharge Function**
- **-40°C ~ +125°C Operating Ambient Temperature**
- **TSOT23-8L or MSOP-10L Package**
- **RoHS Compliant and Halogen-Free**

Operation Mode I – Apple Mode

- Enter mode 2 if data line detection, primary detection
 - $V_{DP} > 2.875V$ for 2ms
 - $V_{DM} < 2.0V$ (1.5V if Apple 2.1A selected) for 10ms
 - $V_{DP} < 2.0V$ for 10ms



Operation Mode II – Samsung Mode

- Enter mode 3 if $0.4 < V_{DP} < 1.05V$ for one second
- Otherwise enters mode 1 when the 3-second counter expires

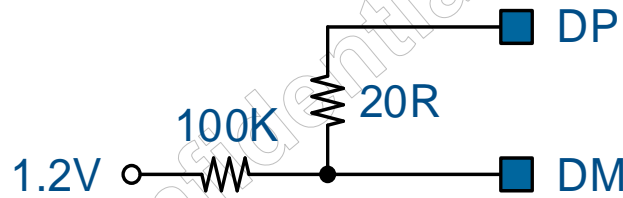

Operation Mode III – BC1.2 Mode

- Enters mode 4 (QC2.0 mode) if $0.4V < V_{DP} < 1.05V$ for 0.2s.
- Otherwise enters mode 1 when the 3-second counter expires

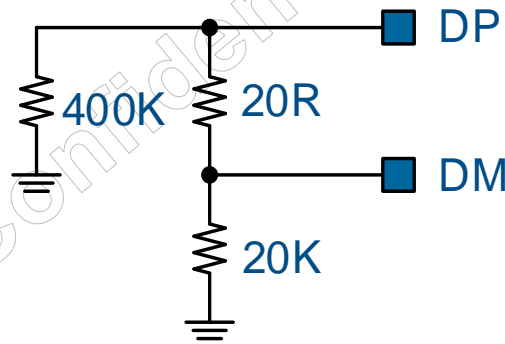

Operation Mode IV – QC Mode

- Leaves mode 4 and enter mode 1 if $V_{DP} < 0.4V$ 2ms or V_{CC} overvoltage protection is triggered
- QC2.0 is confirmed if $V_{DM} < 0.4V$ for 2ms
- NT6008 adjusts output voltage according to QC2.0/3.0 protocol

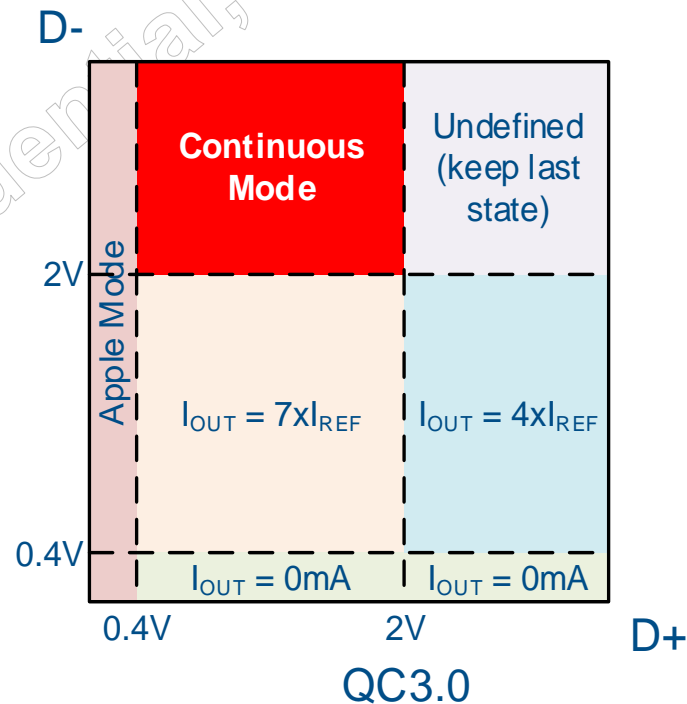
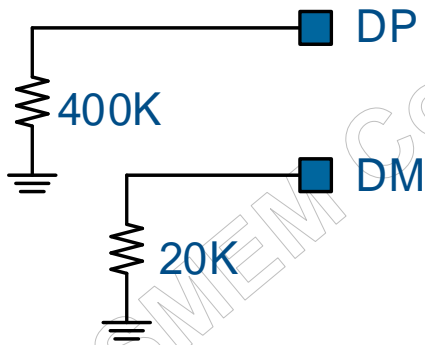

Output Voltage Adjustment

- $I_{REF} = V_{REF} / R_{REF} = 1V/R_{REF}$
- $\Delta V_{BUS} = \Delta K \times I_{REF} * R_{REF} = \Delta K (V)$
- $K = 0$ for 5V; $= 4$ for 9V; $K = 7$ for 12V
- $0.1 \times I_{REF}$, 50us per step to ensure smooth voltage transition
- When voltage decreasing, discharges with 10mA/500ms

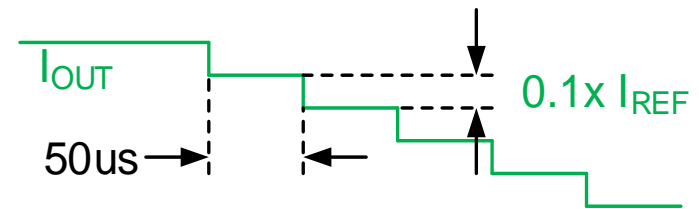
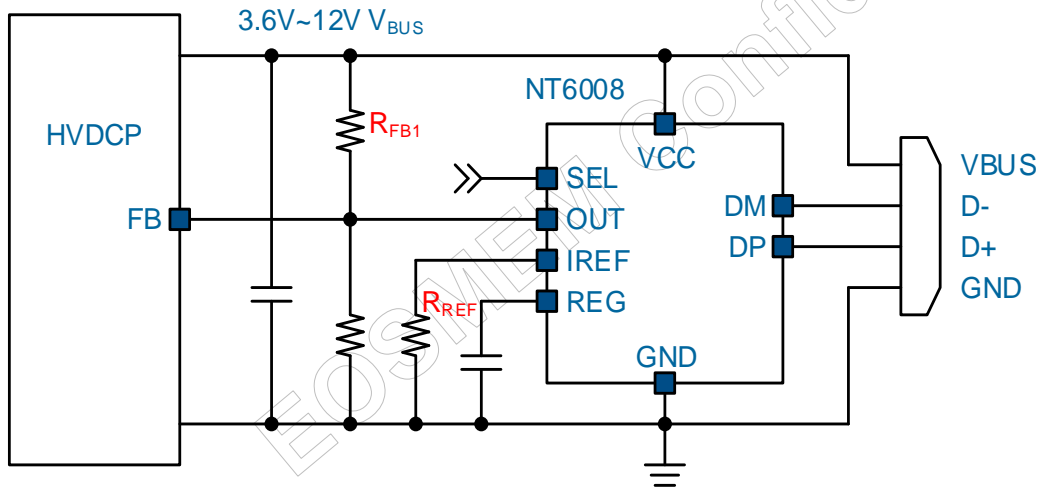

EVB BOM Schematic

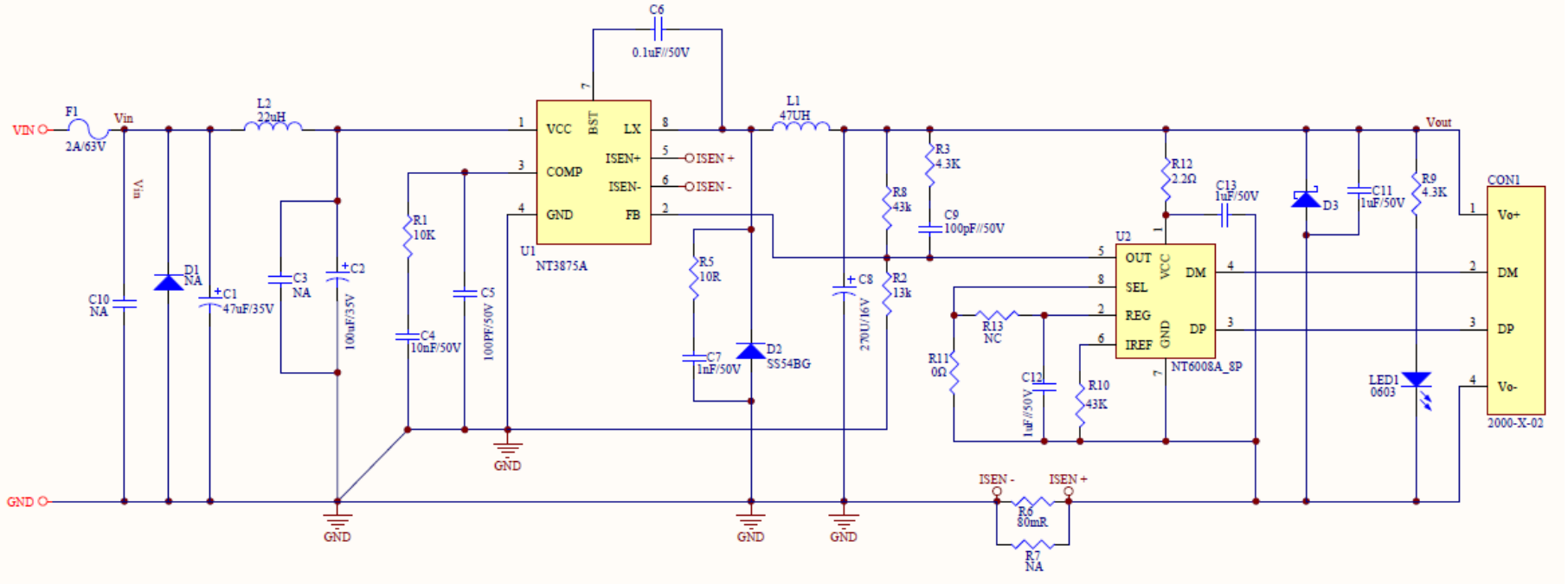

- $V_{IN} = 20V$ to ensure 12V output

EOSMEM CONFIDENTIAL

NT6008 vs. QC2.0 Supporting Phone

- Smooth voltage transition w/o overshoot

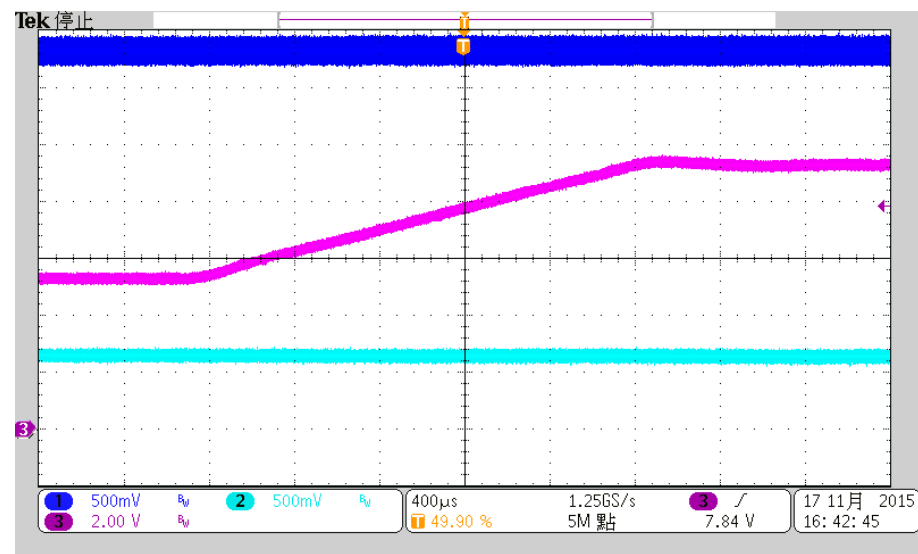
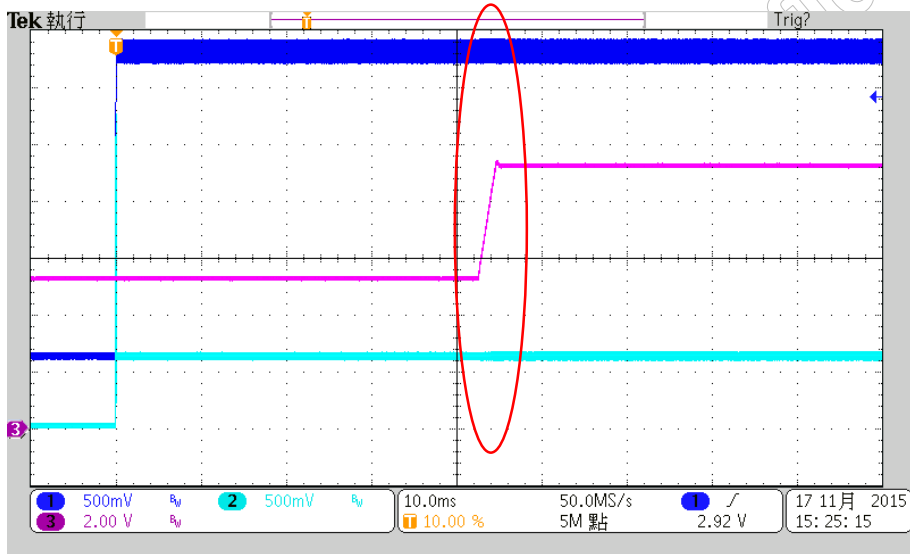
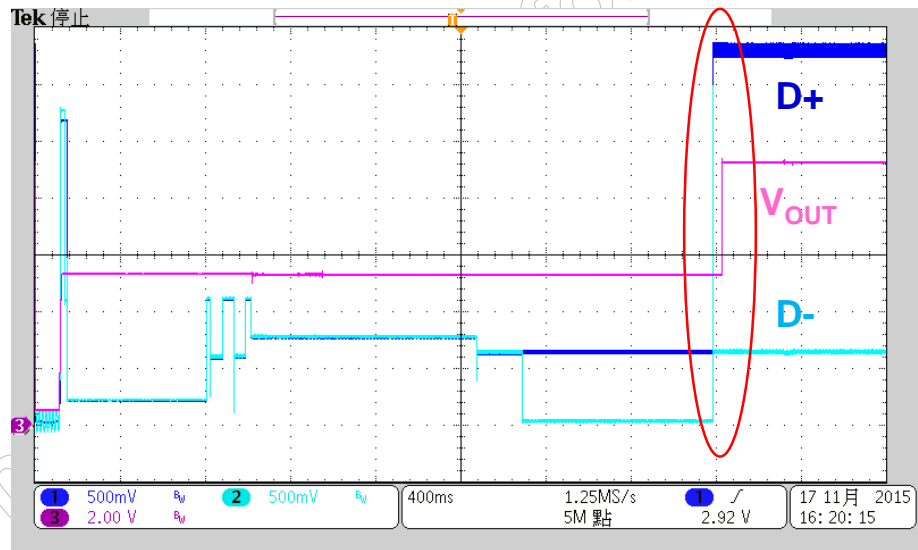

NT6008 vs. QC3.0 Supporting Phone

