



Design Example Report

Title	<i>3W Non-Isolated Buck-Boost Converter using LNK305P</i>
Specification	Input: 108–265 VAC Output: -12 V / 250 mA
Application	Home Appliance
Author	Power Integrations Applications Department
Document Number	DER-49
Date	April 20, 2005
Revision	1.0

Summary and Features

- Non-Isolated Topology - no direct path from input to output
- Low cost off the shelf inductor – no custom transformer required
- 15 components including EMI filter
- Loop Fault Protection
- Short Circuit Protection
- Hysteretic Thermal Shutdown
- Output Referenced to Neutral
- Precise Output Voltage control
- Frequency Jitter
- Excellent Conducted EMI (>10dB margin across spectrum)
- Extremely low standby power consumption (<200mW!)

The products and applications illustrated herein (including circuits external to the products and transformer construction) may be covered by one or more U.S. and foreign patents or potentially by pending U.S. and foreign patent applications assigned to Power Integrations. A complete list of Power Integrations' patents may be found at www.powerint.com.

Table Of Contents

1	Introduction	3
2	Power Supply Specification.....	4
3	Schematic	5
4	Circuit Description	5
5	PCB Layout.....	6
6	Bill Of Materials.....	7
7	Performance Data	8
7.1	Efficiency.....	8
7.2	No-load Input Power	8
7.3	Regulation.....	9
7.3.1	Load.....	9
7.3.2	Line	9
8	Waveforms.....	10
8.1	Source Voltage and Current, Normal Operation	10
8.2	Output Voltage Start-up Profile	10
8.3	Load Transient Response (75% to 100% Load Step).....	11
8.4	Output Ripple Measurements	12
8.4.1	Ripple Measurement Technique	12
8.4.2	Measurement Results.....	13
9	Conducted EMI	14
10	Revision History.....	15

Important Note:

Although this board is designed to satisfy safety requirements, the engineering prototype has not been agency approved. In addition, as the output is not electrically isolated from the input, all testing should be performed using an isolation transformer to provide the AC line input to the prototype board.

Design Reports contain a power supply design specification, schematic, bill of materials, and transformer documentation. Performance data and typical operation characteristics are included. Typically only a single prototype has been built.



1 Introduction

This document is an engineering prototype report describing a non-isolated -12 V, 250mA power supply utilizing a LNK305P.

The document contains the power supply specification, schematic, bill-of-materials, printed circuit layout, and performance data.



Figure 1 –Populated Circuit Board Photograph.

2 Power Supply Specification

Description	Symbol	Min	Typ	Max	Units	Comment
Input						
Voltage	V_{IN}	108		265	VAC	2 Wire – No Protective Earth
Frequency	f_{LINE}	47	50/60	64	Hz	
No-load Input Power (240 VAC)				0.2	W	
Output						
Output Voltage 1	V_{OUT}	10.8	12	13.2	V	±10% 20 MHz Bandwidth 3.5 mA pre-load fitted on board
Output Ripple Voltage 1	$V_{RIPPLE1}$			200	mV	
Output Current 1	I_{OUT}	0		250	mA	
Total Output Power						
Continuous Output Power	P_{OUT}		3		W	
Efficiency	η	50			%	Measured at 85 VAC, 25 °C
Ambient Temperature	T_{AMB}	-20		50/85	°C	Free convection, sea level. For operation at >70 °C substitute D1 for a diode with $t_{rr} \leq 35$ ns

Table 1 - Specifications



3 Schematic

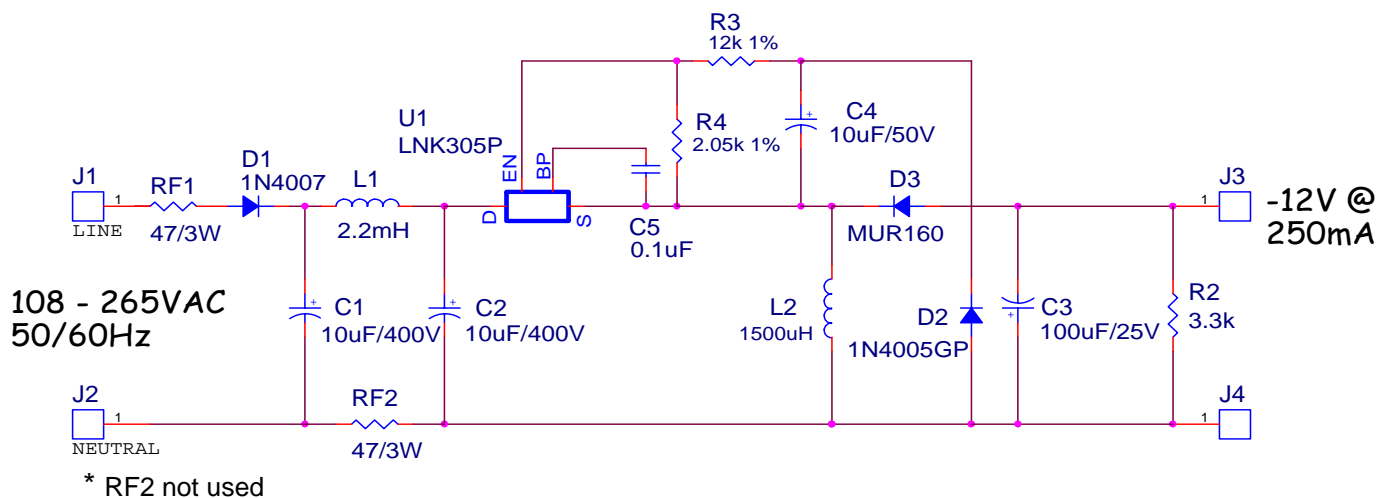

Figure 2 –Schematic.

4 Circuit Description

The circuit shown in Figure 2 is a non-isolated buck-boost (inverting) topology. The input voltage range is 108 to 265VAC 50/60Hz and provides a regulated -12V at 250mA. The buck-boost topology is essentially the non-isolated version of the Flyback Converter, in that the transformer is replaced with a single low cost inductor (L2).

RF1 is a fusible link resistor. The input AC is half-wave rectified and filtered by D1 and C1. C1, L1 and C2 form a pi-filter network to reduce common-mode emissions imposed to the input line, this in conjunction with the built-in frequency jitter of the LinkSwitch-TN (U1) ensure sufficient conducted EMI margins. U1, D2 and L2 form the buck-boost switching cell, which converts the rectified bulk positive DC voltage on C2 into a negative voltage on C3 (w/r/t Neutral/GND). D2 samples the output voltage onto C4 as a positive voltage with respect to the source of U1. The EN pin of U1 is internally set to 1.65V (w/r/t pins 1,2, 7 and 8) this in conjunction with resistors R3 and R4 form a simple voltage divider to precisely set the output voltage to the desired level. C5 is a bypass capacitor that serves as high frequency decoupling and energy storage. This capacitor provides power to the IC as well as controls the auto-restart mechanism in the LinkSwitch-TN. Resistor R2 serves to reduce peak charging effects on C3 which tend to increase the output voltage, its static power dissipation is limited to less than 30mW. Without this additional resistor the standby power consumption would be less than 100mW.



5 PCB Layout

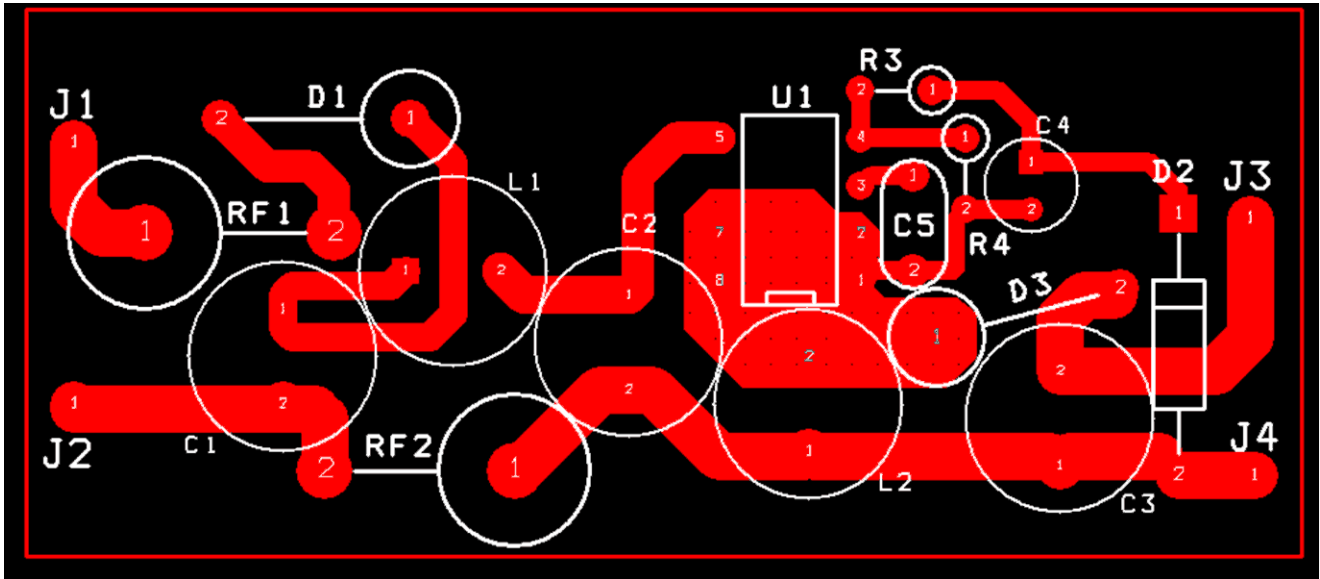

Figure 3 – Printed Circuit Layout



6 Bill Of Materials

<i>Item</i>	<i>QTY</i>	<i>Ref Des</i>	<i>Value</i>	<i>Manufacturer</i>	<i>P/N</i>
1	2	C1, C2	10uF/400V		
2	1	C3	100uF/25V		
3	1	C4	10uF/50V		
4	1	C5	0.1uF/50V		
5	1	D1	Standard Rec. 1A/1000V	Diodes, Inc.	1N4007
6	1	D2	Standard Rec. 1A/600V	Diodes, Inc.	1N4005GP
7	1	D3	Ultrafast 1A/600V	Diodes, Inc.	MUR160
8	1	L1	2.2mH	Toko	262LY-222K
9	1	L2	1500uH	Toko	824MY-152K
10	1	R2	3.3k 5% 1/4W		
11	1	R3	12k 1% 1/8W		
12	1	R4	2.05k 1% 1/8W		
13	1	RF1	47 ohm/3W	RCD Components	
14	1	U1	PWM +MOSFET	Power Integrations	LNK305P



7 Performance Data

All measurements performed at room temperature, 60 Hz input frequency.

7.1 Efficiency

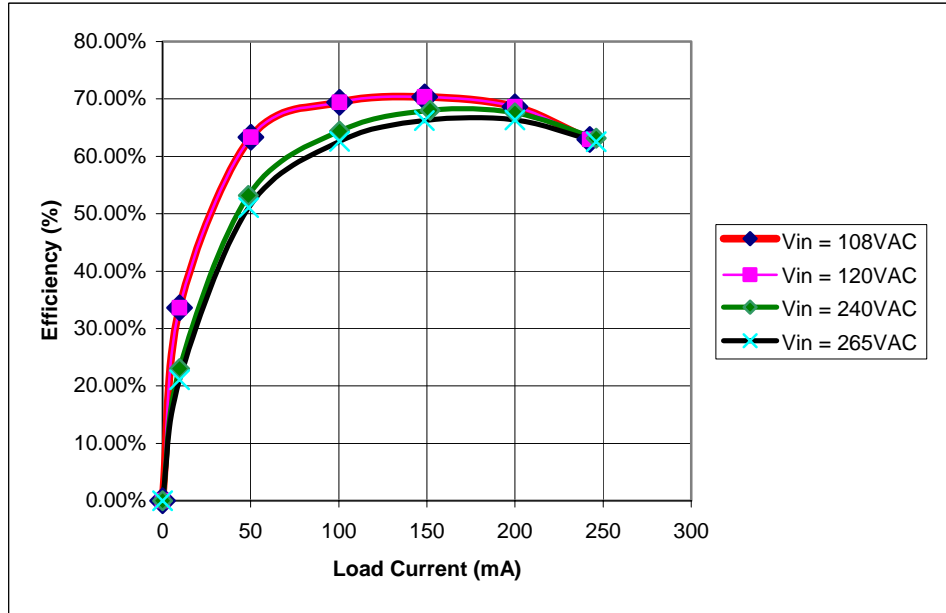

Figure 4 - Efficiency vs. Output Current, Room Temperature, 60 Hz.

7.2 No-load Input Power

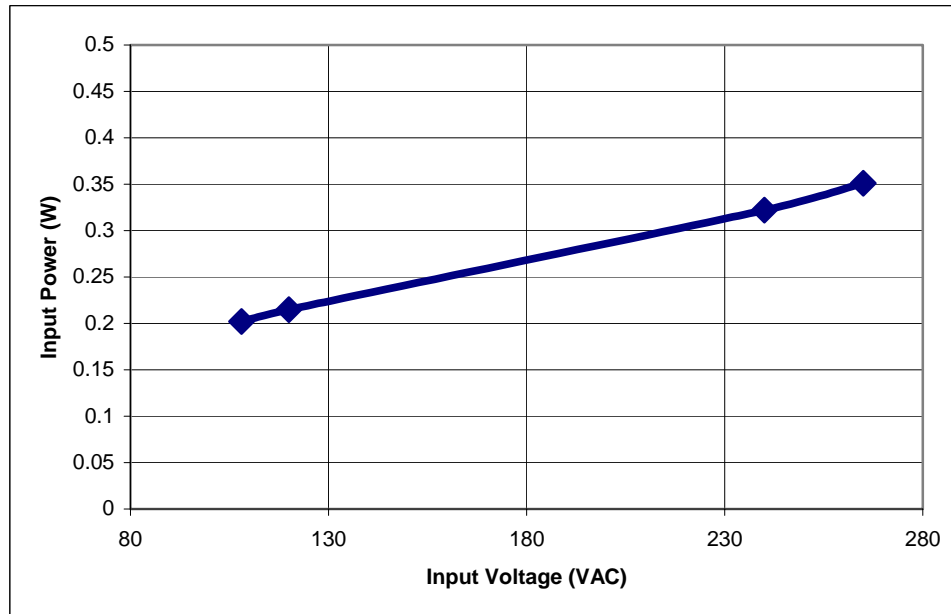

Figure 5 - Zero Load Input Power vs. Input Line Voltage, Room Temperature, 60 Hz.



7.3 Regulation

7.3.1 Load

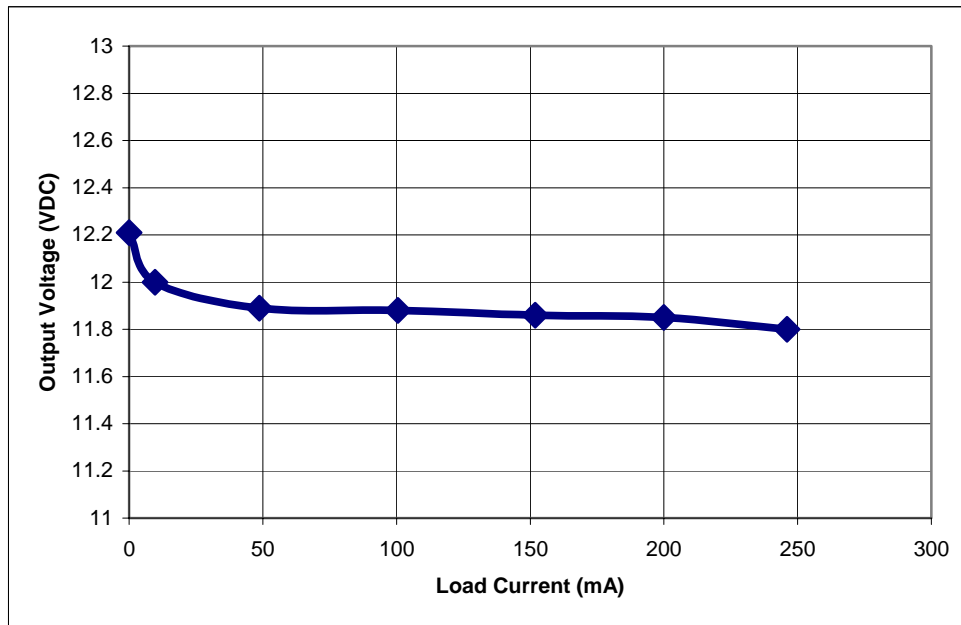

Figure 6 - Load Regulation, $V_{in} = 120VAC$, Room Temperature.

7.3.2 Line

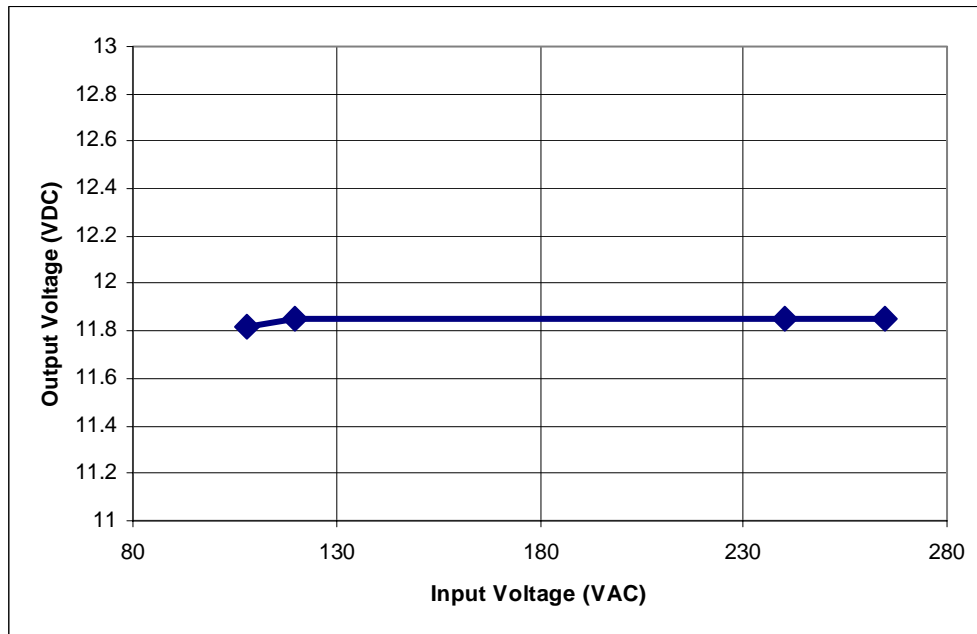

Figure 7 - Line Regulation, Full Load, Room Temperature.



8 Waveforms

8.1 Source Voltage and Current, Normal Operation

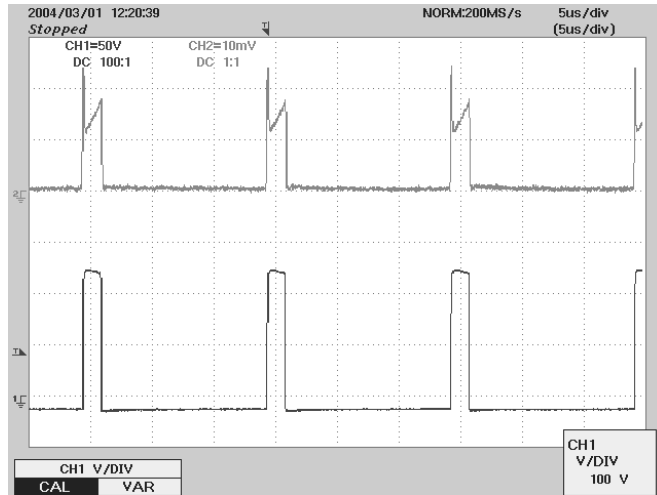

Figure 8 - 108 VAC, Full Load.
 Upper: I_{DRAIN} , 0.2 A / div
 Lower: V_{SOURCE} , 50 V, 5 μ s / div

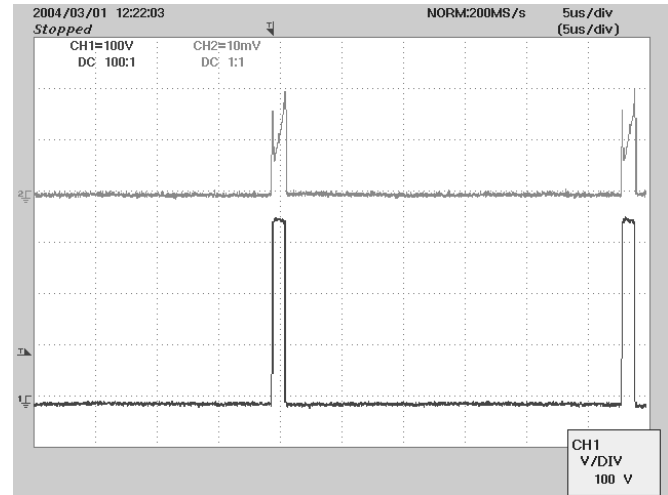

Figure 9 - 265 VAC, Full Load.
 Upper: I_{DRAIN} , 0.2 A / div
 Lower: V_{SOURCE} , 100 V / div

8.2 Output Voltage Start-up Profile



Figure 10 - 108 VAC Input and Maximum Load.
 5 V / div, 10 ms

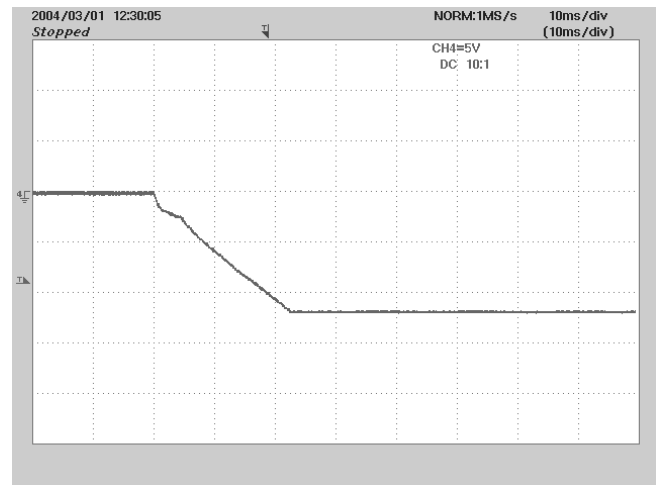

Figure 11 - 265 VAC Input and Maximum Load.
 5 V / div, 10 ms



8.3 Load Transient Response (75% to 100% Load Step)

The oscilloscope was triggered using the load current step as a trigger source.

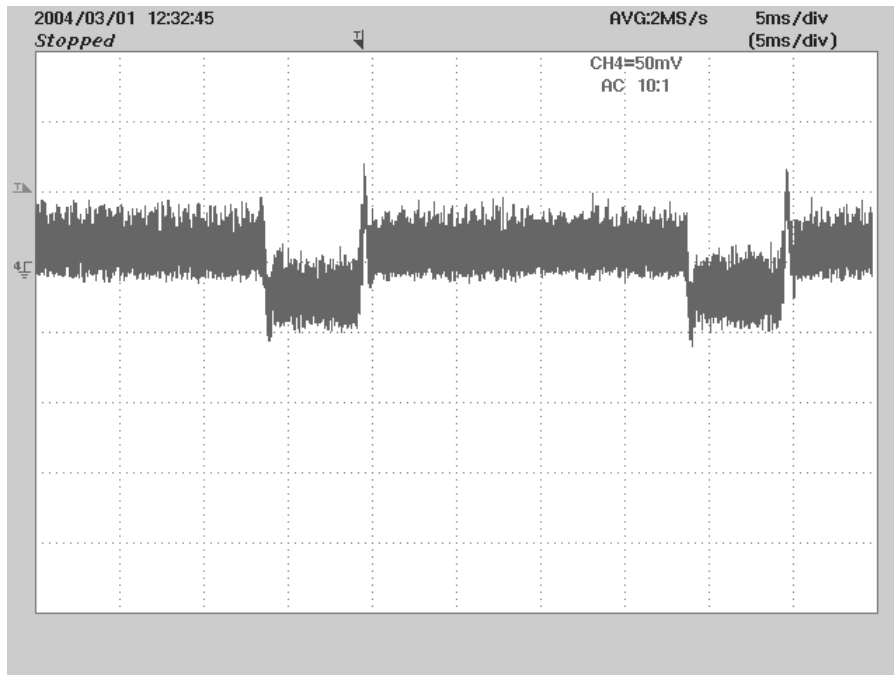

Figure 12 -120 VAC Input and Maximum Load.

50 mV / div, 5 ms / div

8.4 Output Ripple Measurements

8.4.1 Ripple Measurement Technique

For DC output ripple measurements, a modified oscilloscope test probe must be utilized in order to reduce spurious signals due to pickup. Details of the probe modification are provided in Figure 13 and Figure 14.

The 5125BA probe adapter is affixed with two capacitors tied in parallel across the probe tip. The capacitors include one (1) 0.1 $\mu\text{F}/50\text{ V}$ ceramic type and one (1) 1.0 $\mu\text{F}/50\text{ V}$ aluminum electrolytic. **The aluminum electrolytic type capacitor is polarized, so proper polarity across DC outputs must be maintained (see below).**

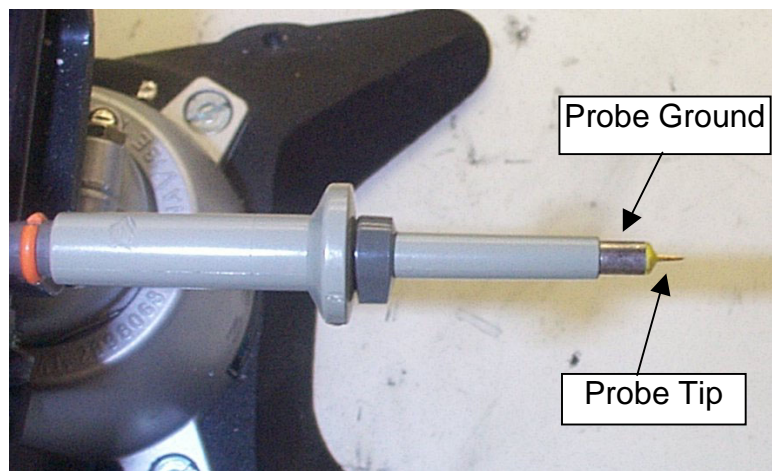

Figure 13 - Oscilloscope Probe Prepared for Ripple Measurement. (End Cap and Ground Lead Removed).

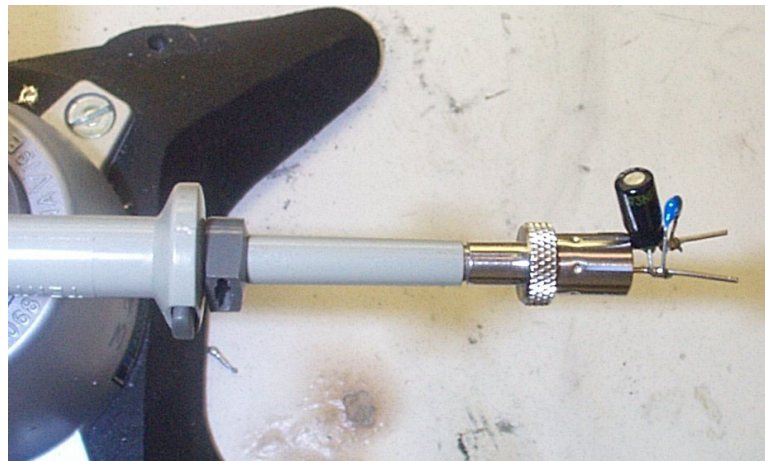

Figure 14 - Oscilloscope Probe with Probe Master 5125BA BNC Adapter (Modified with Wires for Probe Ground for Ripple Measurement and Two Parallel Decoupling Capacitors Added).

8.4.2 Measurement Results

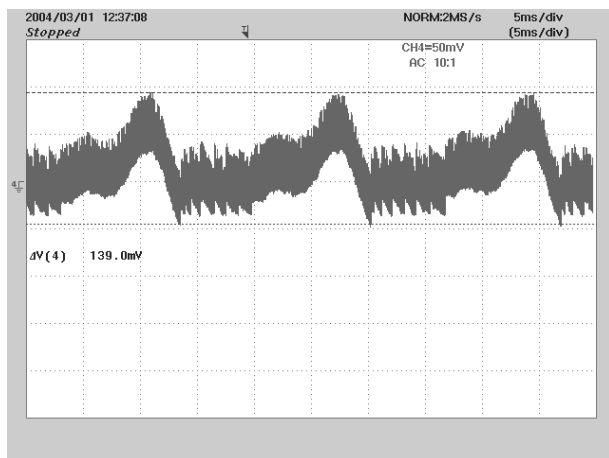

Figure 15 - Ripple, 108 VAC, Full Load.
5 ms, 50 mV / div

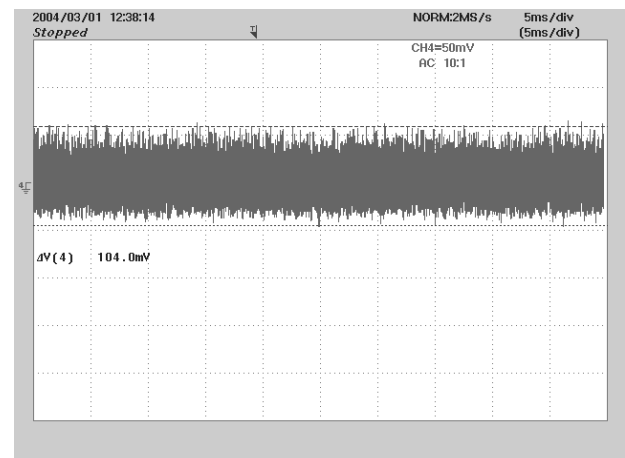

Figure 16 - Ripple, 265 VAC, Full Load.
5 ms, 50 mV / div



9 Conducted EMI

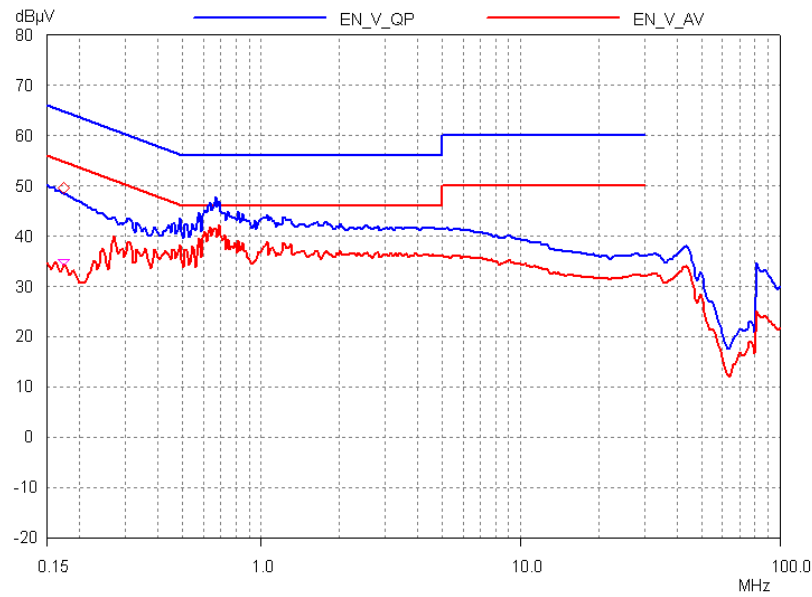

Figure 17- Conducted EMI EN55022 B Limits - 120 VAC/60Hz Maximum Steady State Load (**LINE**)

Note: If more EMI margin is desired, an additional 1N4007 can be added in series with the NEUTRAL input

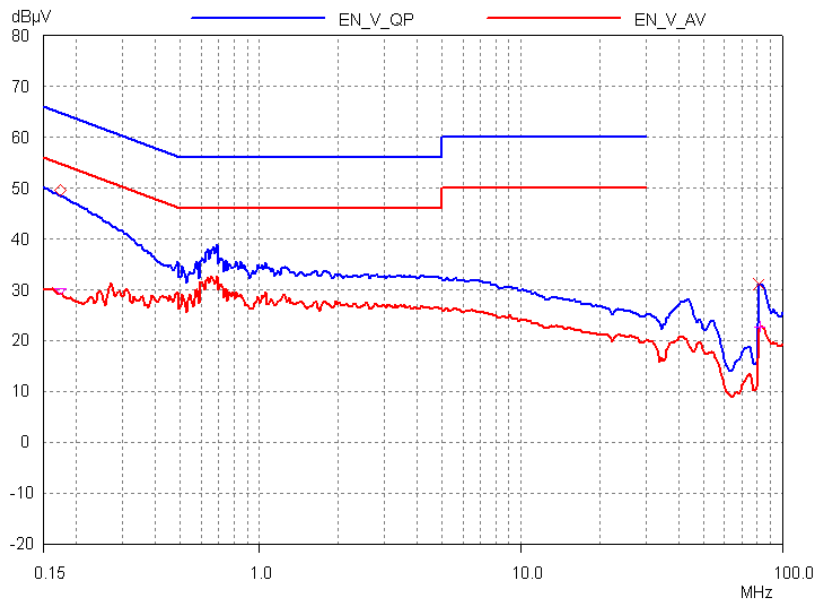

Figure 18- Conducted EMI EN55022 B Limits - 120 VAC/60Hz Maximum Steady State Load (**Neutral**)



10 Revision History

Date	Author	Revision	Description & changes	Reviewed
April 20, 2005	RSP	1.0	Initial Release	VC/JC / AM



NOTES



For the latest updates, visit our Web site: www.powerint.com

Power Integrations may make changes to its products at any time. Power Integrations has no liability arising from your use of any information, device or circuit described herein nor does it convey any license under its patent rights or the rights of others. POWER INTEGRATIONS MAKES NO WARRANTIES HEREIN AND SPECIFICALLY DISCLAIMS ALL WARRANTIES INCLUDING, WITHOUT LIMITATION, THE IMPLIED WARRANTIES OF MERCHANTABILITY, FITNESS FOR A PARTICULAR PURPOSE, AND NON-INFRINGEMENT OF THIRD PARTY RIGHTS.

PATENT INFORMATION

The products and applications illustrated herein (including circuits external to the products and transformer construction) may be covered by one or more U.S. and foreign patents or potentially by pending U.S. and foreign patent applications assigned to Power Integrations. A complete list of Power Integrations' patents may be found at www.powerint.com.

The PI Logo, **TOPSwitch**, **TinySwitch**, **LinkSwitch**, and **EcoSmart** are registered trademarks of Power Integrations. **PI Expert** and **DPA-Switch** are trademarks of Power Integrations.

© Copyright 2004, Power Integrations.

Power Integrations Worldwide Sales Support Locations

WORLD HEADQUARTERS

5245 Hellyer Avenue,
San Jose, CA 95138, USA
Main: +1-408-414-9200
Customer Service:
Phone: +1-408-414-9665
Fax: +1-408-414-9765
e-mail:
usasales@powerint.com

CHINA (SHANGHAI)

Rm 807, Pacheer,
Commercial Centre,
555 Nanjing West Road,
Shanghai, 200041, China
Phone: +86-21-6215-5548
Fax: +86-21-6215-2468
e-mail:
chinasales@powerint.com

CHINA (SHENZHEN)

Rm# 1705, Bao Hua Bldg.
1016 Hua Qiang Bei Lu,
Shenzhen, Guangdong,
518031, China
Phone: +86-755-8367-5143
Fax: +86-755-8377-9610
e-mail:
chinasales@powerint.com

APPLICATIONS HOTLINE

World Wide +1-408-414-9660

GERMANY

Rueckertstrasse 3,
D-80336, Munich, Germany
Phone: +49-895-527-3910
Fax: +49-895-527-3920
e-mail: eurosales@powerint.com

INDIA (TECHNICAL SUPPORT)

Innovatech
261/A, Ground Floor
7th Main, 17th Cross,
Sadashivanagar
Bangalore, India, 560080
Phone: +91-80-5113-8020
Fax: +91-80-5113-8023
e-mail: indiasales@powerint.com

ITALY

Via Vittorio Veneto 12, Bresso,
Milano,
20091, Italy
Phone: +39-028-928-6001
Fax: +39-028-928-6009
e-mail: eurosales@powerint.com

APPLICATIONS FAX

World Wide +1-408-414-9760

JAPAN

Keihin-Tatemono 1st Bldg.
12-20 Shin-Yokohama,
2-Chome,
Kohoku-ku, Yokohama-shi,
Kanagawa 222-0033, Japan
Phone: +81-45-471-1021
Fax: +81-45-471-3717
e-mail:
japansales@powerint.com

KOREA

8th Floor, DongSung Bldg.
17-8 Yoido-dong,
Youngdeungpo-gu,
Seoul, 150-874, Korea
Phone: +82-2-782-2840
Fax: +82-2-782-4427
e-mail:
koreasales@powerint.com

SINGAPORE

51 Newton Road,
#15-08/10 Goldhill Plaza,
Singapore, 308900
Phone: +65-6358-2160
Fax: +65-6358-2015
e-mail:
singaporesales@powerint.com

TAIWAN

17F-3, No. 510,
Chung Hsiao E. Rd., Sec. 5,
Taipei, Taiwan 110, R.O.C.
Phone: +886-2-2727-1221
Fax: +886-2-2727-1223
e-mail:
taiwansales@powerint.com

UK (EUROPE & AFRICA HEADQUARTERS)

1st Floor, St. James's House
East Street
Farnham, Surrey GU9 7TJ
United Kingdom
Phone: +44-1252-730-140
Fax: +44-1252-727-689
e-mail: eurosales@powerint.com

ER or EPR template – Rev 3.6 – Single sided

