

## Data Sheet

---

---

|                    |                   |
|--------------------|-------------------|
| Type Description : | E2930A-30W12-L01  |
| Product Name :     | RM8 <b>6*6PIN</b> |
| Reversion :        | 1.1.0             |
| Reversion Date :   | 2015.08.20        |
| Page :             | 3 Pages           |

# E2930A-30W12-L01

## RM8 6\*6PIN

### 變壓器規格 Transformer Specification

#### 1 外形尺寸 Mechanical Dimensions :

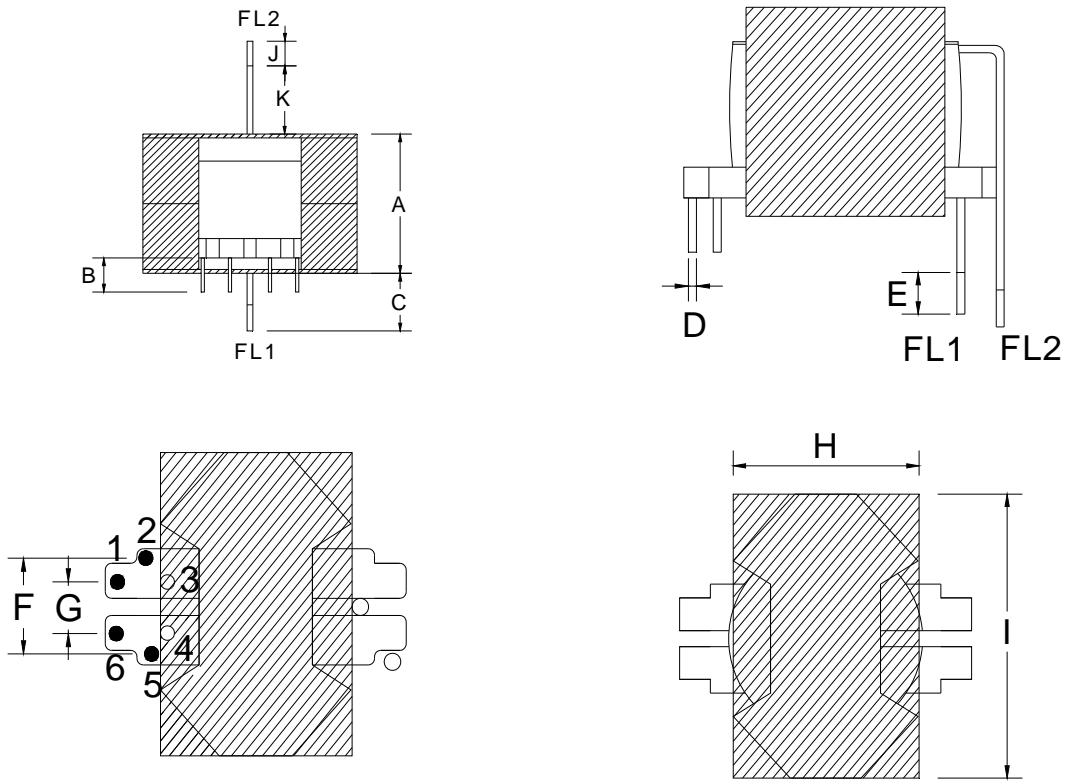

外觀圖：



# E2930A-30W12-L01

## RM8 6\*6PIN

NOTE:

1. 進出線全部皆加 TFL 套管。
2. NS 為三層絕緣線,飛線需絞線鍍錫。
3. FB 穿透明套管,由無 PIN 端頂部出線,飛線長度從頂部 CORE 量起,套管長 35±1,裸線長 5+2/-0,
4. FA 穿黑色套管,由無 PIN 端底部進線,飛線長度從底部 CORE 量起套管長 10±1,裸線長 5+2/-0,
5. 繞線需平整緊密,
6. 產品需含浸,
7. 剪掉PIN3、4脚,
8. 繞完裝磁芯后需用膠紙包2Ts,磁芯線包不能有外露,如外觀圖示,
9. NP1 和 NP2 之 A 線為抽頭;待 NP2 結束再絞線鍍錫穿套管折回線包內,

### 2 绕组数据 Winding Data :

| Winding                                   | Wire Size                     | Start | Finish | Turns | UL Tape | Tube | Note    |
|---|-------------------------------|-------|--------|-------|---------|------|---------|
| NP1                                       | Φ0.35*1P 2UEW (含漆<br>0.37 mm) | 6     | A      | 23Ts  | /       | /    | 2 层绕满   |
| Tape                                      | /                             |       |        |       | 2Ts     | /    |         |
| CP  | 0.025t*7m m寬                  | 5     |        |       | 1.1 Ts  |      | 0.25 引線 |
| Tape                                      | /                             |       |        |       | 2Ts     | /    |         |
| NS  | 三層絕緣線內徑0.55mm*2P              | LF1   | LF2    | 5Ts   | /       | /    | 1 层绕满   |
| Tape                                      | /                             |       |        |       | 2Ts     | /    |         |
| CP  | 0.025t*7m m寬                  | 5     |        |       | 1.1 Ts  |      | 0.25 引線 |
| Tape                                      | /                             |       |        |       | 2Ts     | /    |         |
| NP2                                       | Φ0.35*1P 2UEW (含漆<br>0.37 mm) | A     | 2      | 23Ts  | /       | /    | 1 层绕满   |
| Tape                                      | /                             |       |        |       | 2Ts     | /    |         |
| NA  | Φ0.20*2 2UEW (含漆<br>0.22 mm)  | 1     | 5      | 7 Ts  | /       | /    | 1 层疏绕   |
| Tape                                      | /                             |       |        |       | 2Ts     | /    |         |
| NP1 和 NP2 之 A 線為抽頭;待 NP2 結束再絞線鍍錫穿套管折回線包內. |                               |       |        |       |         |      |         |

# E2930A-30W12-L01

## RM8 6\*6PIN

### 3 原理图 Schematic:

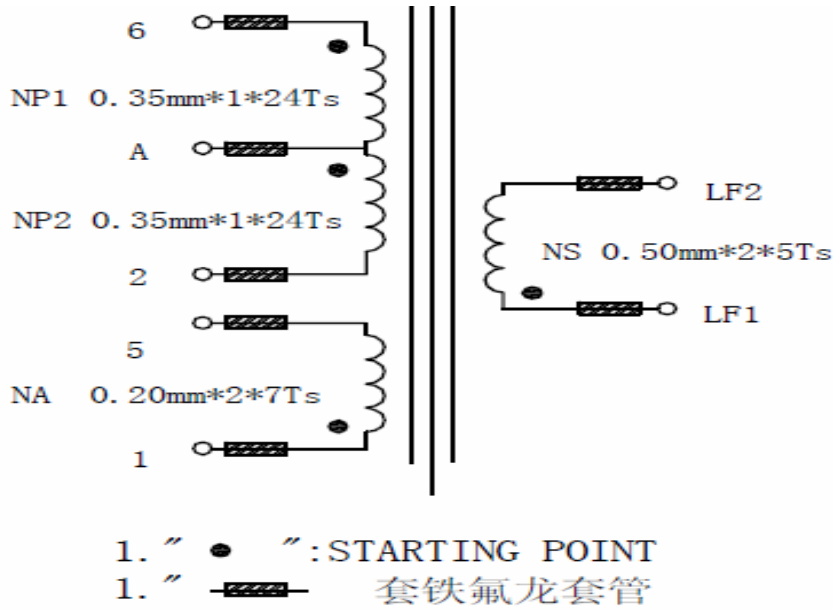

### 4 电气特性 Electrical Characteristics:

| No | DESCRIPTION        | PIN NO.     |         | SPEC              | TEST CONDITION        |
|----|--------------------|-------------|---------|-------------------|-----------------------|
| 1  | INDUCTANCE         | L           | 6-2     | 700UH $\pm$ 30 uH | 10KHz/1V              |
| 2  | Leakage inductance | 10KHz/1V    | 6-2     | 10UH              | Short pin LF1 LF2 2 6 |
| 3  | DC RESISTANCE      | RDC         | 2-6     | 50 M $\Omega$ Max | 25°C                  |
|    |                    |             | 5-1     | 50 M $\Omega$ Max | 25°C                  |
|    |                    |             | LF1-LF2 | 50 M $\Omega$ Max | 25°C                  |
| 4  | HI-POT TEST        | PRI to SEC  |         | 3.0KVac           | 20MA/1分鐘              |
| 5  |                    | PRI to CORE |         | 3.0KVac           |                       |
| 6  |                    | SEC to CORE |         |                   |                       |
| 7  |                    |             |         |                   |                       |

### 5 材料清单 Material List

| Item | Name            | Description    | Class | 安規         |
|------|-----------------|----------------|-------|------------|
| 1    | Core 磁芯         | PC44 or 同等級    | /     |            |
| 2    | Bobbin 骨架       | RM8 6*6PIN骨架尺寸 | 150°C | E59481     |
| 3    | Magnet wire 漆包線 | UEW-U, MW#75   | 130°C | E142108    |
| 4    | Mylar Tape      | #1350NO.44     | 130°C | E17385(N)  |
| 5    | Margin Tape     | #44            | 130°C | E17385(N)  |
| 6    | Copper          | 0.025T*8mmW    | 130°C | /          |
| 7    | Epoxy           | G-8500A/B      | /     | E216733    |
| 8    | Sleeving        | TFL            | 200°C | E156256(S) |