

## LED Controller for LLC converters

### Features

- Advanced LED Controller IC for high efficiency low-cost LLC converters with bipolar transistors and integrated PFC
- PSR - +/-5% Primary Side Regulation of LED current and voltage
- 50% duty cycle, variable frequency control of resonant half-bridge
- Automatic dead-time control and capacitive mode protection
- Protection modes:
  - Overload
  - No-Load
  - Over-temperature
  - Control Loop Fault protection
- Low output capacitance allows live LED connection
- Very low output current ripple
- Small SO8N IC package



SO8N

### Applications

- Low Flicker PFC LED drivers 5-70W
- High Efficiency APFC LED drivers 50-150W

### Order code

Part Number	Package	Packaging
RED2501AD-TR13	SO8N	Tape and reel

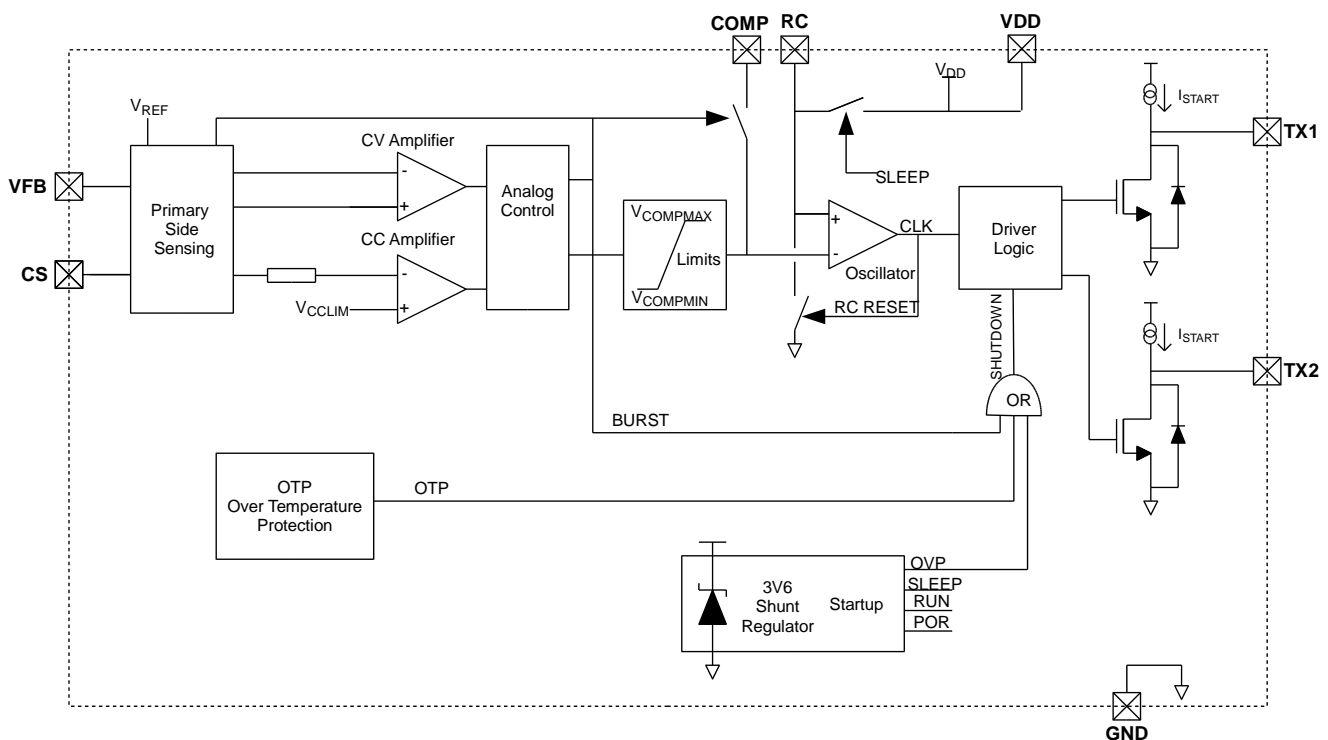

Figure 1: Block diagram

## Device Pins

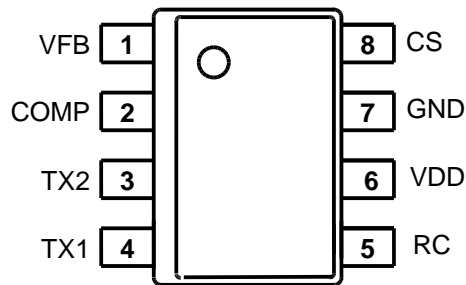

Figure 2: SO8N pin connections (top view)

## Pin Functions

Pin #	Name	Function
1	VFB	PSR Feedback input for output voltage regulation. Connect to primary sense winding.
2	COMP	Buffered output of the control amplifiers. A loop compensation network connected between this pin and the VFB input defines CV mode loop response.
3	TX2	Output to control transformer.
4	TX1	Output to control transformer.
5	RC	External RC network sets the minimum [full power] switching frequency.
6	VDD	IC Power Supply pin – nominally 3.45V
7	GND	Chip ground.
8	CS	PSR Current Sense input provides output current regulation and cycle-by-cycle over-current protection. The CS pin is connected to the half-bridge current sense resistor

## Typical Application

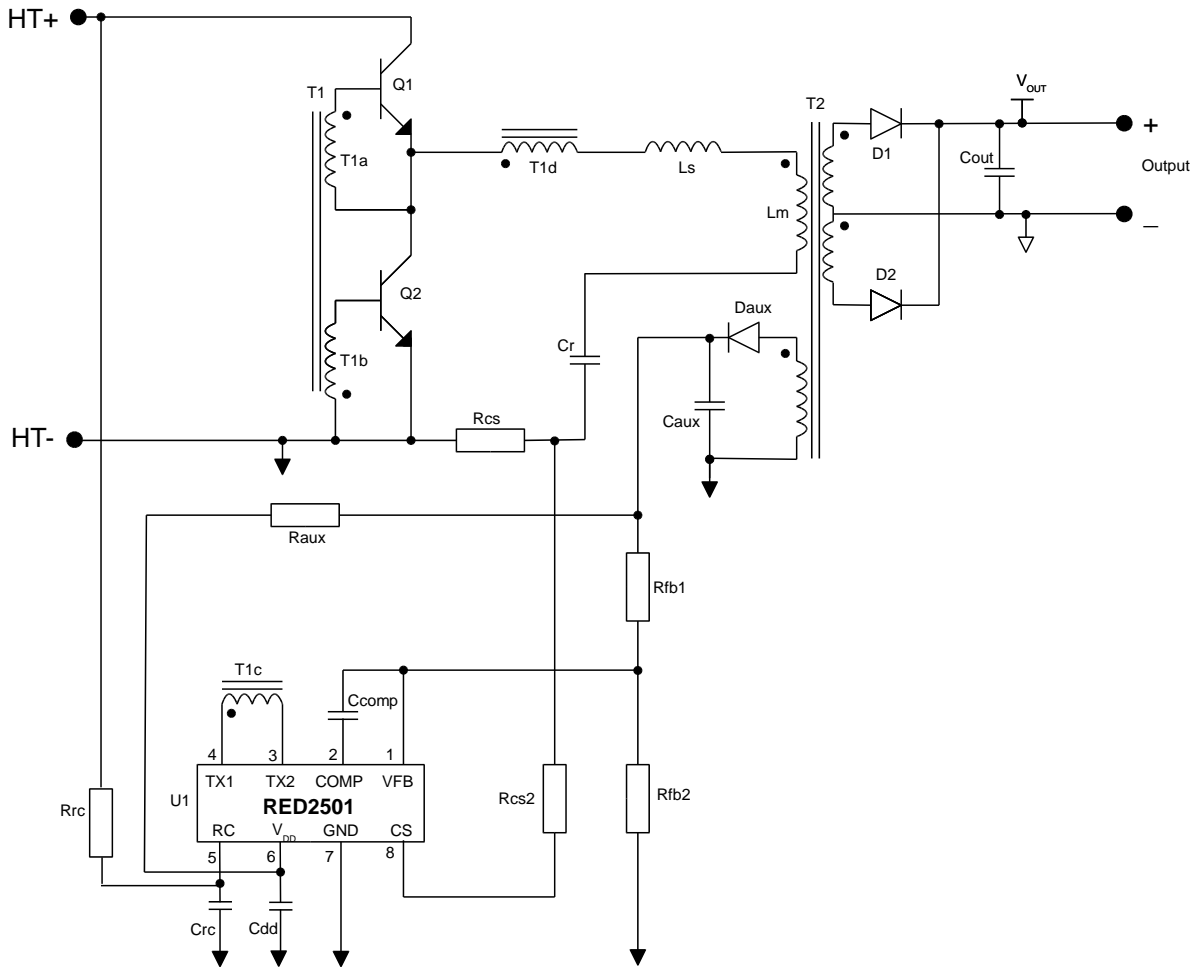

Figure 3: Typical Application Schematic: LLC converter with RED2501 PSR controller

## Features

RED2501 is an advanced CMOS control IC for resonant LLC converters. The RED2501 Primary Side Regulation (PSR) control scheme accurately controls the LED current and removes the need for secondary side opto-coupler feedback, reducing cost and complexity.

RED2501 uses the CSOC (Controlled Self-Oscillating Converter) scheme to drive two low-cost bipolar transistors in a half-bridge configuration. RED2501 is optimized to work with RediSem's LLC converter topology with integrated Power Factor Correction.

Please contact RediSem for application design information for LED drivers with PFC.

### Accurate Primary Side Regulation

The RED2501 PSR scheme regulates the LED drive current by modulating the converter frequency. Primary side current control enables +/-5% LED current regulation. With the LED

disconnected, the RED2501 controls the maximum output voltage and enters controlled burst-mode operation to keep the output voltage from rising and to keep the power consumption low.

### Protection Features

If the output voltage rises too high (no load) RED2501 enters CV burst mode of operation.

If the output is short-circuit, the auxiliary power to the IC fails and the IC shuts down. From this condition the IC automatically cyclically re-starts until the short-circuit has been removed.

The IC also has an instantaneous cycle-by-cycle over-current protection (OCP) level that will terminate any cycle instantaneously should the current exceed a pre-set level.

The PSR control's Feedback Protection Feature (FBP) shuts down the controller if the feedback signal to the VFB pin is lost.



### ***Over-temperature Protection***

The RED2501 Over-temperature protection (OTP) feature shuts down the controller if the IC temperature exceeds 125°. The IC will restart the converter when the IC temperature drops by 25°C.

### ***Automatic Dead-Time Control***

An important feature of the Controlled Self Oscillating Converter is that the dead-time is controlled naturally. Unlike MOSFET half-bridge converters, it is not necessary to program the dead-time on RED2501. The bipolar switching

transistors are turned on correctly through the self-oscillation of the converter and turned off by RED2501. This greatly simplifies the design process and improves the robustness of the LLC converter.

### ***Capacitive Mode Protection***

RED2501 includes a capacitive mode protection feature which prevents the converter from entering capacitive switching mode on a cycle-by-cycle basis by limiting the minimum frequency. This always ensures the Controlled Self Oscillating Converter continues to oscillate correctly.

## IC Operation

### Startup, Shutdown and re-start

Figure 4 shows typical startup waveforms for RED2501. In SLEEP mode the  $I_{DD}$  current is approximately 8uA ( $I_{DD\text{SLEEP}}$ ). Once VDD reaches 3.6V ( $V_{DD\text{START}}$ ) the IC goes into RUN mode. The controlled Zener clamp inside the IC turns on and regulates the VDD voltage to 3.45V ( $V_{DD\text{REG}}$ ). The IC current is now approximately 650uA ( $I_{DD\text{REG}}$ ) plus any excess current required

to clamp VDD to 3.45V. If VDD falls below 3.45V ( $V_{DD\text{REG}}$ ) the Zener clamp turns off and  $I_{DD}$  reduces to 650uA ( $I_{DD\text{REG}}$ ) only. If VDD falls by 570mV ( $\Delta V_{DD\text{SA}}$ ) below  $V_{DD\text{REG}}$ , the IC tries to keep itself alive by entering RUN mode and issuing start pulses. If VDD falls by 1.05V ( $\Delta V_{DD\text{SLEEP}}$ ) below  $V_{DD\text{REG}}$ , the IC enters SLEEP mode. In this condition  $I_{DD}$  reduces to 8uA. ( $I_{DD\text{SLEEP}}$ ).

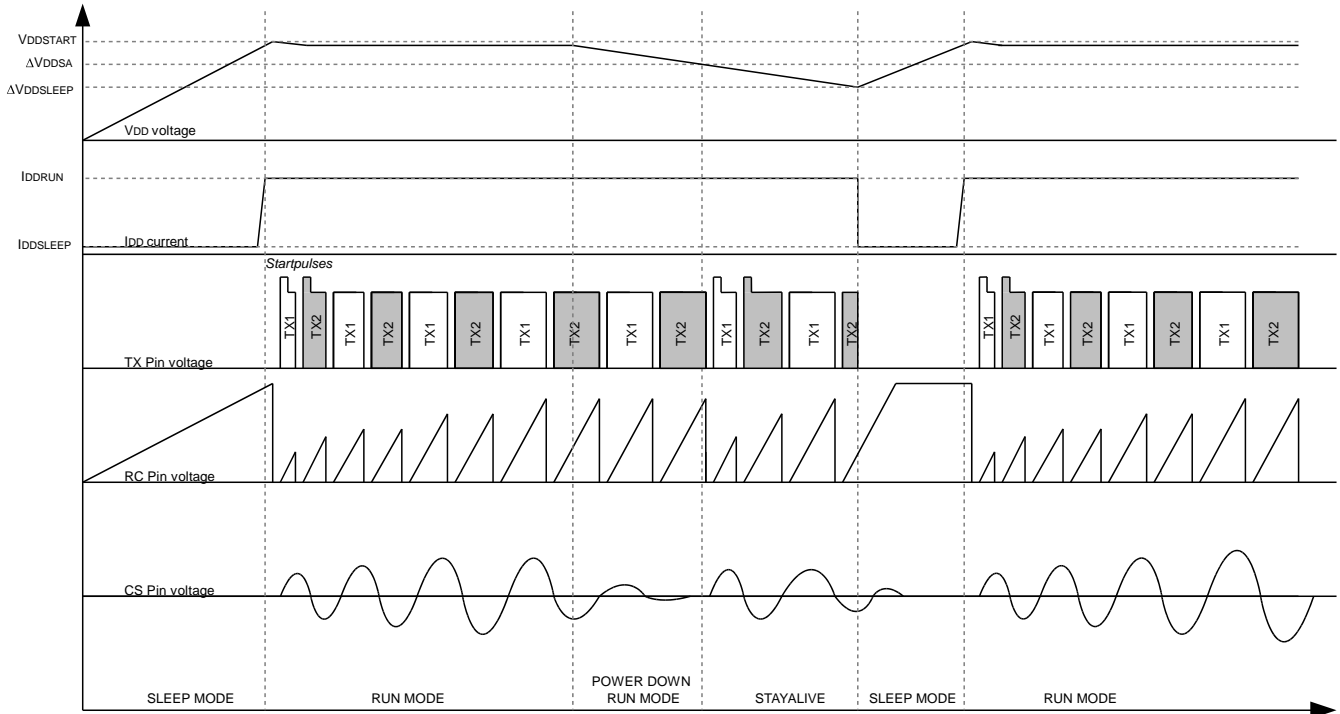

Figure 4: IC Start-up waveforms

### Output stage

A diagram of the output stage can be seen in Figure 5. To start the converter oscillating the RED2501 issues start pulses through the TX pins during the first two cycles. These start pulses are 500ns long ( $t_{TX\text{START}}$ ) and provide 14mA ( $I_{TX\text{START}}$ ) current pulses from both TX1 and TX2 pins. After this the converter self-oscillates and no longer needs start pulses to maintain

oscillation. A low on-state NMOS transistor is used to turn the bipolar transistors off. It is controlled by the oscillator off-time. The NMOS device is turned to pull TX pin low, which switches off the corresponding bipolar transistor in the power converter half-bridge.

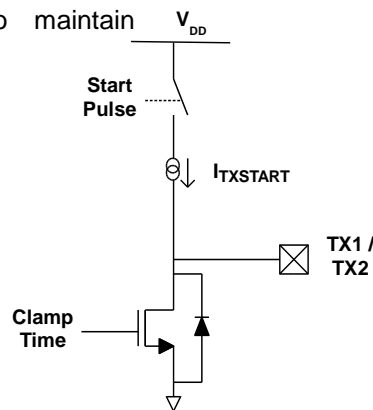

Figure 5: Output Stage

## Primary Side Regulation (PSR)

The converter's output current and voltage are estimated by the RED2501 PSR scheme. Inside the IC there are two separate control loops that control the converter output current (in CC mode) and voltage (in CV mode). The RED2501 regulates the output current and voltage by

controlling the frequency. A control voltage ( $V_{COMP}$ ) is fed into the oscillator to give the desired operating frequency. Figure 6 shows how the two current and voltage error amplifiers and their compensation networks are configured for a primary regulated LLC converter.

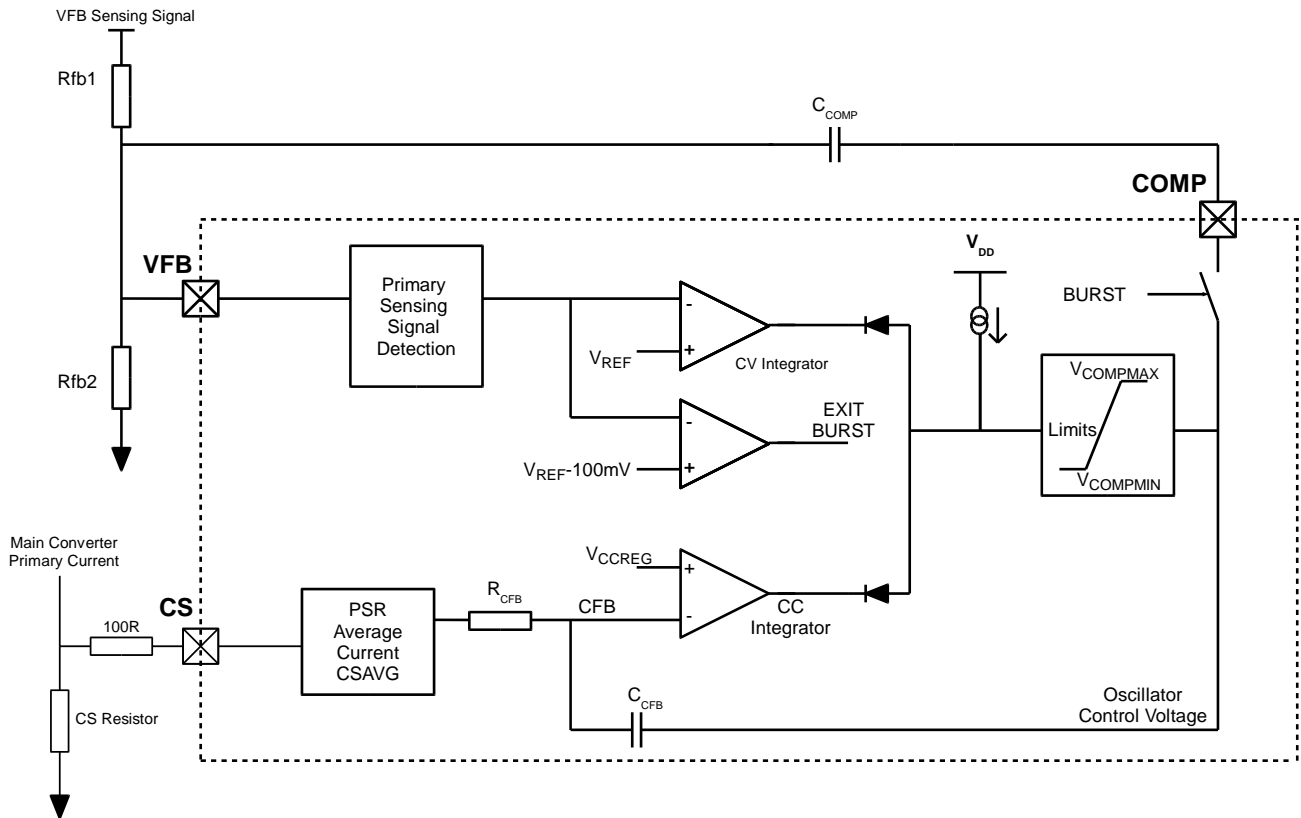

Figure 6: Error Amplifier Circuits

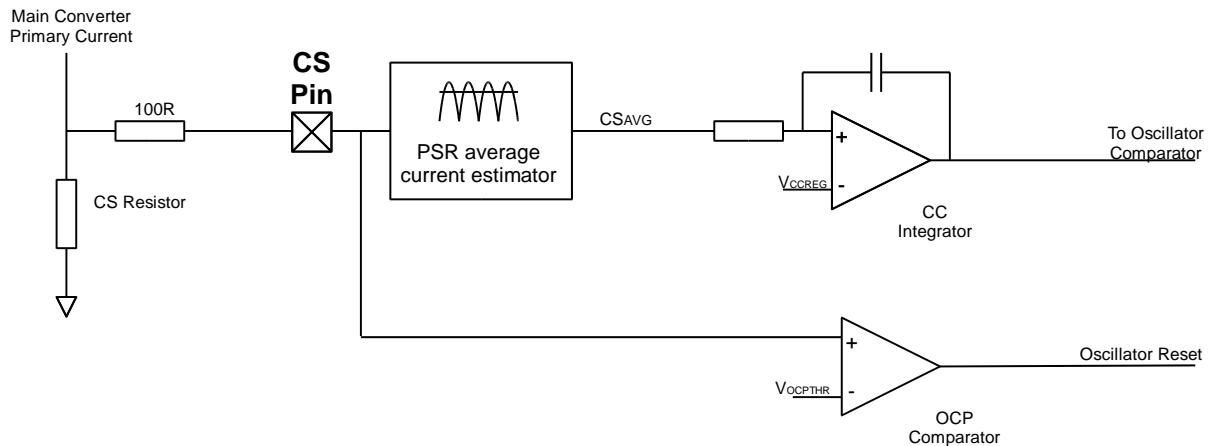

Figure 7: RED1401 Current protection and control circuits

## PSR Current Control

Figure 7 shows the two current control methods used in the converter:

1. constant current (CC) regulation;
2. an instantaneous peak current limit (OCP).

### PSR Average current estimation

Shown in figure 7 the signal from the CS pin is divided into two different paths. The bottom path provides peak instantaneous over-current protection (OCP) while the PSR Average Current estimation block provides the current regulation (CC) information. The voltage on the CS pin is an AC signal biased around GND. Inside the PSR block this signal is processed to provide a voltage proportional to the average converter output current.

### Constant Current Regulation

The CC regulation circuit is shown in Figure 7. CC operation is defined by an internally compensated control loop. This provides a system response time of approximately 1ms in a typical application. The average current regulation point,  $V_{CCREG}$  is pre-set to mV, referred to the CS pin.

### Over Current Protection

Over-Current Protection (OCP) is an instantaneous termination of the transistor on-time. When a peak voltage greater than  $\pm 500\text{mV}$  ( $V_{OCPTHR}$ ) is sensed on the CS pin the

OCP comparator terminates the current oscillator on-time cycle. The oscillator is reset and the off-time begins resulting in the bipolar transistors turning off and the half-bridge commutating. This is repeated in subsequent cycles whenever the CS voltage exceeds the threshold. However, in a correctly designed converter it should not be possible to trip OCP in normal operation.

### PSR Voltage Control

The RED2501 voltage control loop is used to control the maximum LED converter output voltage. The VFB input senses the output voltage from an auxiliary winding on the primary side of the transformer. This signal is conditioned in the PSR block and compared to a voltage reference of 1.1V ( $V_{REF}$ ) inside the IC. If the voltage exceeds 1.2V RED2501 will enter controlled burst mode.

In a constant current LED application the VFB voltage will normally be below the 1.2V regulation point  $V_{REF}$  as the CC control loop determines the COMP voltage. At light loads or no load the CC loop is not in control and the VFB voltage will rise to the 1.2V  $V_{REF}$  control voltage. At that point RED2501 will enter controlled burst mode to maintain a controlled output voltage. The external feedback network in figure 6 between the COMP and VFB pins defines the loop gain and phase for the voltage control loop. RED2501 includes a VFB feedback protection feature that stops the converter if the PSR feedback signal to the VFB pin is lost.

## Oscillator

The oscillator (see Figure 8) controls the period of a converter half-cycle. Internal to the IC is an oscillator comparator that compares the voltage on the RC pin to the voltage on the COMP pin. The RC pin has a saw tooth type waveform and the COMP signal should have a steady voltage, inversely proportional to the required frequency. The COMP pin voltage can vary from 0.55V ( $V_{COMPMIN}$ ) to 2.35V ( $V_{COMPMAX}$ ), resulting in a maximum to minimum frequency ratio of approximately 3 for any input voltage.

The timing capacitor  $C_{RC}$  may be chosen within the range 100 – 1000 pF. The recommended type is a 5% COG/NPO capacitor. The oscillator timing resistor  $R_{RC}$  may be connected to either  $V_{DD}$  or to the rectified DC bus,  $V_{HT}$ . If connected to  $V_{DD}$ , the value of  $R_{RC}$  may be calculated using following equation.

$$F_{MIN} = \frac{1}{2 \left( 0. \mu s - R_{RC} \cdot C_{RC} \cdot \ln \left( 1 - \frac{2.35}{3.45} \right) \right)}$$

This equation gives the lowest possible operating frequency of the converter.

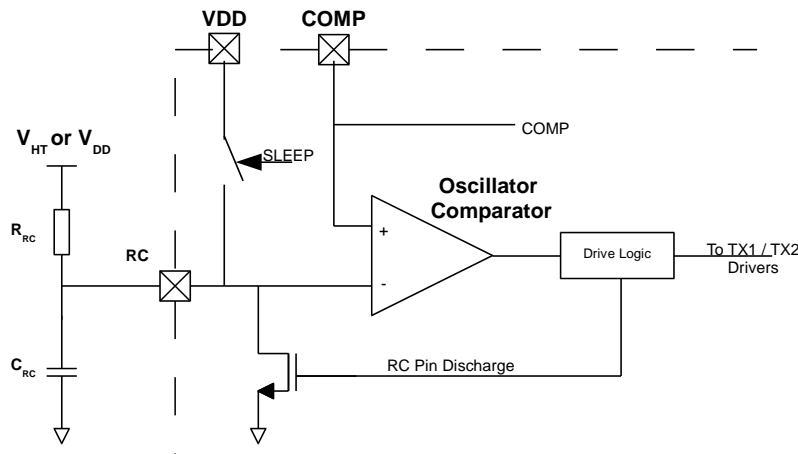

Figure 8: Oscillator circuit

## Oscillator Feed-forward Compensation

The oscillator may optionally include feed-forward compensation. Feed-forward compensation is recommended to minimise the line frequency ripple on the output. To apply the feed-forward compensation, the oscillator pull-up resistor  $R_{RC}$  is connected to the DC bulk supply  $V_{HT}$  instead of  $V_{DD}$ . The value may be calculated as a function of the DC bulk voltage using the following equation:

$$F_{MIN} = \frac{1}{2 \left( 0. \mu s + R_{RC} \cdot C_{RC} \cdot 2.35 / V_{HT} \right)}$$

To assist feed-forward applications, a switch is provided which connects the VDD pin to the RC pin while the controller is in SLEEP. This allows the  $R_{RC}$  resistor to pull up the VDD supply for start up.





## ABSOLUTE MAXIMUM RATINGS

CAUTION: Permanent damage may result if a device is subjected to operating conditions at or in excess of absolute maximum ratings.

Parameter	Symbol	Condition	Min	Max	Unit
Supply voltage	$V_{DD}$		-0.5	4.5	V
Supply current	$I_{DD}$		0	10	mA
Input/output voltages	$V_{IO}$		-0.5	$V_{DD} + 0.5$	V
Input/output currents	$I_{IO}$		-10	10	mA
Junction temperature	$T_J$		-20	+125	°C
Storage temperature	$T_P$		-20	+125	°C
Lead temperature	$T_L$	Soldering, 10 s		260	°C
ESD withstand		Human body model, JESD22-A114		2	kV
		Capacitive Discharge Model		500	V

## NORMAL OPERATING CONDITIONS

Unless otherwise stated, electrical characteristics are defined over the range of normal operating conditions. Functionality and performance is not defined when a device is subjected to conditions outside this range and device reliability may be compromised.

Parameter	Symbol	Condition	Min	Typ	Max	Unit
Minimum supply current	$I_{DDMIN}$		0.8	1.0	1.2	mA
Junction temperature	$T_J$		-20	25	125	°C

## ELECTRICAL CHARACTERISTICS

Unless otherwise stated:

- Min and Max electrical characteristics apply over normal operating conditions.
- Typical electrical characteristics apply at  $T_J = T_{J(TYP)}$  and  $I_{DD} = I_{DDREG(TYP)}$ .
- The chip is operating in RUN mode.
- Voltages are specified relative to the GND pin.

### VDD Pin

Parameter	Symbol	Condition	Min	Typ	Max	Unit
Supply voltage	$V_{DDSTART}$	To enter RUN mode	3.2	3.6	4.0	V
	$V_{DDREG}$	$I_{DD} < I_{DDSHUNT}$	3.3	3.45	3.6	V
	$\Delta V_{DDSA}$	To trigger STAYALIVE signal		570		mV
	$\Delta V_{DDSLLEEP}$	To enter SLEEP mode		1.05		V
Supply current	$I_{DDREG}$	In RUN mode, $V_{DD} < V_{DDREG}$		650	800	$\mu A$
	$I_{DDSLLEEP}$	In SLEEP mode		8	12	$\mu A$
	$I_{DDSHUNT}$	VDD shunt regulator max current			8	mA



# RED2501 PSR LLC Controller

## VFB Pin

Parameter	Symbol	Condition	Min	Typ	Max	Unit
VFB threshold voltage	V <sub>REF</sub>	T <sub>J</sub> = 0°C to 85°C, V <sub>DD</sub> =3.45V	1.15	1.20	1.25	V
VFB Hysteresis voltage	ΔV <sub>EXITSBY</sub>	In burst mode	90	100	110	mV

## CS Pin

Parameter	Symbol	Condition	Min	Typ	Max	Unit
Constant current regulation	V <sub>CCREG</sub>	50kHz, squarewave CS signal. T <sub>J</sub> = 0°C to 85°C	142	145	148	mV
Instantaneous over-current protection threshold	V <sub>OCP</sub> THR			500		mV

## RC Pin

Parameter	Symbol	Condition	Min	Typ	Max	Unit
External capacitor range	C <sub>RC</sub>		100		1000	pF
Oscillator Frequency Variation	ΔF <sub>RC</sub> /F <sub>RC</sub>	T <sub>J</sub> = -0°C to 85°C, C <sub>RC</sub> =330pF, V <sub>DD</sub> =3.45V, V <sub>COMP</sub> = V <sub>COMP</sub> MAX			4	%
Oscillator reset time	T <sub>RCRST</sub>			0.7		μs

## COMP Pin

Parameter	Symbol	Condition	Min	Typ	Max	Unit
Source/Sink current	I <sub>COMP</sub>		-40		+40	μA
Maximum COMP voltage	V <sub>COMP</sub> MAX	V <sub>DD</sub> =3.45V		2.35		V
Minimum COMP voltage	V <sub>COMP</sub> MIN	V <sub>DD</sub> =3.45V		0.55		V

## TX1, TX2 Pins

Parameter	Symbol	Condition	Min	Typ	Max	Unit
On-state resistance	R <sub>TXON</sub>			1.5	2	Ω
TX pin clamp current	I <sub>TXCLAMP</sub>	TX pin frequency >30kHz			800	mA
Start-pulse output current	I <sub>TXSTART</sub>		12	14	16	mA
Start-pulse width	T <sub>TXSTART</sub>		300	500	700	ns

## Over-Temperature Protection (OTP)\*

Parameter	Symbol	Condition	Min	Typ	Max	Unit
Over-Temperature Protection threshold	T <sub>OTPS</sub>	At silicon junction	90	100	110	°C
Over-Temperature Protection reset hysteresis	T <sub>OTP_HYS</sub>	At silicon junction		15		°C

\*: not tested in production

## PACKAGE INFORMATION

### Package Dimensions

SO8N package dimensions are shown below. All units are in mm.

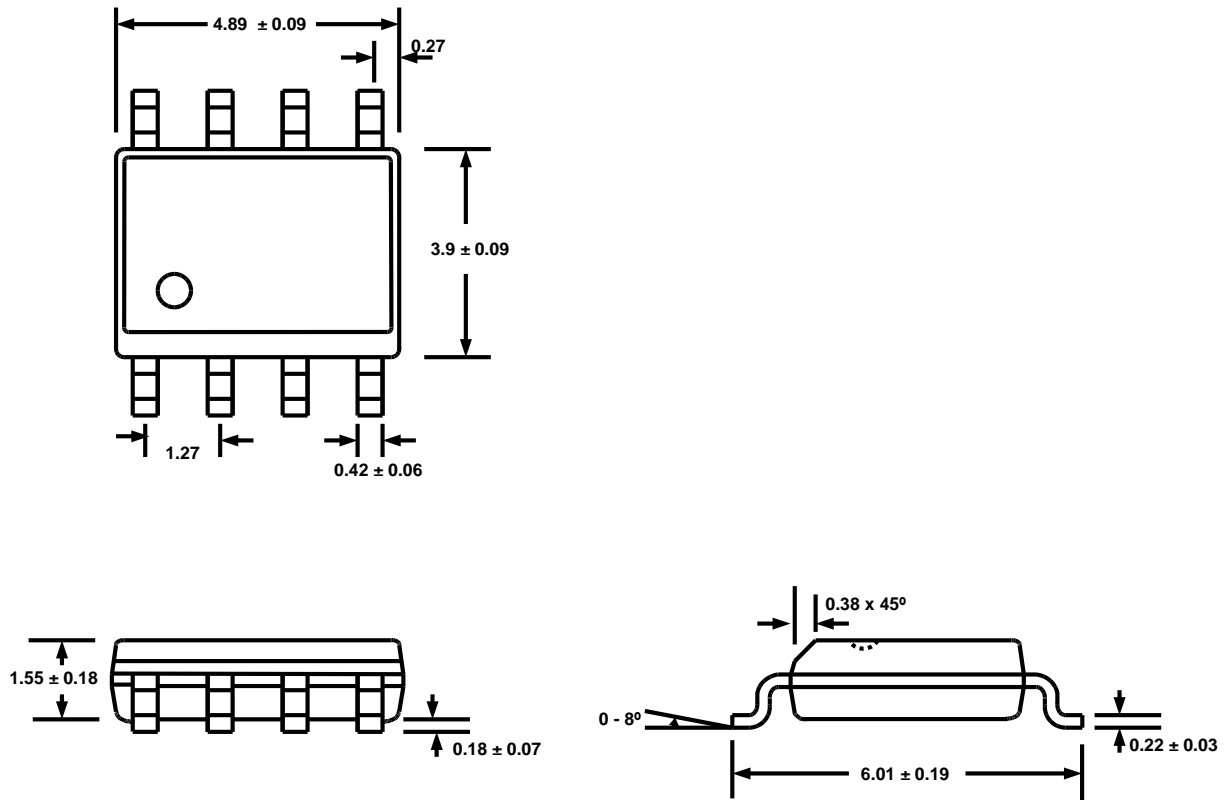

### Available packages

Package type	Part number	Moisture Sensitivity Level (MSL)	Packaging
SO8N	RED2501AD-TR13	3 (JEDEC J-STD-020)	Tape and reel 2500 / 13" reel

### Package Marking

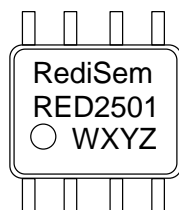

#### SO8N top-side marking for RED2501

RED2501= Part Number

WXYZ= Lot Code, e.g. AAAA, AAAB



## Status

The status of this Datasheet is shown in the footer.

Datasheet Status	Product Status	Definition
Preview	In development	The Datasheet contains target specifications relating to design and development of the described IC product.
Preliminary	In qualification	The Datasheet contains preliminary specifications relating to functionality and performance of the described IC product.
Production	In production	The Datasheet contains specifications relating to functionality and performance of the described IC product which are supported by testing during development and production.

## Contact Details

**RediSem Ltd.**  
301-302 IC Development Centre  
No 6 Science Park West Avenue  
Hong Kong Science & Technology Park  
Shatin, New Territories  
Hong Kong

Tel. +852 2607 4141  
Fax. +852 2607 4140  
Email: [info@redisem.com](mailto:info@redisem.com)  
Web: [www.redisem.com](http://www.redisem.com)

## Disclaimer

The product information provided herein is believed to be accurate and is provided on an “as is” basis. RediSem Ltd assumes no responsibility or liability for the direct or indirect consequences of use of the information in respect of any infringement of patents or other rights of third parties. RediSem Ltd does not grant any licence under its patent or intellectual property rights or the rights of other parties.

Any application circuits described herein are for illustrative purposes only. Specifications are subject to change without notice. In respect of any application of the product described herein RediSem Ltd expressly disclaims all warranties of any kind, whether express or implied, including, but not limited to, the implied warranties of merchantability, fitness for a particular purpose and non-infringement of third party rights. No advice or information, whether oral or written, obtained from RediSem Ltd shall create any warranty of any kind. RediSem Ltd shall not be liable for any direct, indirect, incidental, special, consequential or exemplary damages, howsoever caused including but not limited to, damages for loss of profits, goodwill, use, data or other intangible losses.

The products and circuits described herein are subject to the usage conditions and end application exclusions as outlined in RediSem Ltd Terms and Conditions of Sale.

RediSem Ltd reserves the right to change specifications without notice. To obtain the most current product information available visit [www.redisem.com](http://www.redisem.com) or contact us at the address shown above.