

Metal Alloy Ga U`-Resistance Resistor

Product Specification:GR2725 4W Type

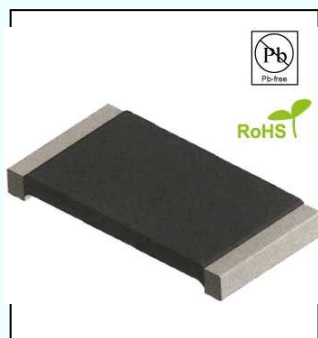

FEATURES :



- ◆ Ideal for all types of current sensing, voltage division and Pulse applications including switching and linear power Supplies, Instruments, power amplifiers.
- ◆ Proprietary processing technique produces extremely low Resistance values.
- ◆ High-temperature performance (up to +275°C)
- ◆ Very low inductance 0.5nH to 5nH
- ◆ Excellent frequency response
- ◆ Low thermal EMF (<1uV/°C)
- ◆ Lead(Pb)-free construction is RoHS-compliant

1. Standard Electrical Specifications :

Model	Power Rating at 100 °C (Watts)	Resistance Range mΩ	
		1.0%(F)	5.0%(J)
SR2725-24	4.0	0.25~3	0.25~3

4 Watts with total solder pad trace size of 400mm²

2. Technical Specifications :

Parameter	Unit	SR2725-24 (mΩ)
Temperature Coefficient	ppm /°C	0.25~0.9= +50 1~3= -25
Operating Temperature Range	°C	-65 ~ + 275
Maximum Working Voltage	V	$(P \times R)^{1/2}$

Ordering Information :

GR2725 - & (F \$ \$ % : : % ...

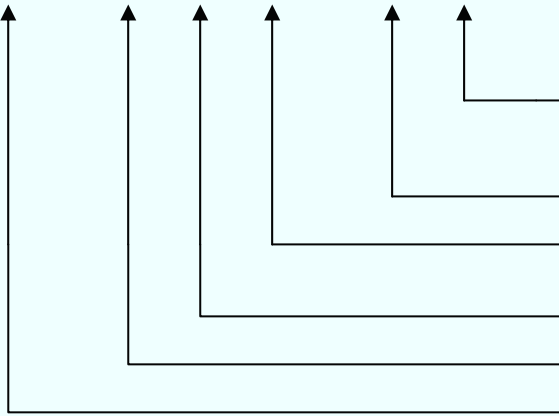

Packing

1=Tape & Reel ; B=Bulk Pack

1=1,000 Pcs

Tolerance

D=±0.5% ; F=±1.0% ; J=±5.0%

Resistance

EX : R001=1mΩ ; R010=10mΩ

Power Rating (Watts)

Number of Terminals

Model (Size)

3. Dimensions :

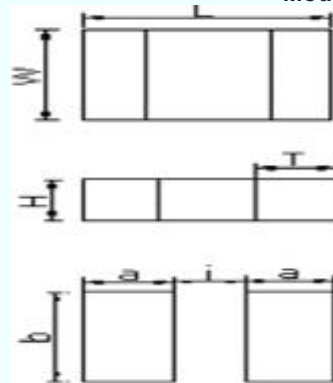

Model	DIMENSIONS - in inches (millimeters)				
	Resistance Range mΩ	L	W	H	T
SR2725-24	0.25	0.268±0.010 (6.8±0.254)	0.264±0.010 (6.7±0.254)	0.039±0.010 (1.0±0.254)	0.085±0.010 (2.15±0.254)
	1			0.043±0.010 (1.1±0.254)	0.085±0.010 (2.15±0.254)
SR2725-24	1.5	0.268±0.010 (6.8±0.254)	0.264±0.010 (6.7±0.254)	0.039±0.010 (1.0±0.254)	0.085±0.010 (2.15±0.254)
	2			0.035±0.010 (0.9±0.254)	0.071±0.010 (1.8±0.254)
	2.5	0.268±0.010 (6.8±0.254)	0.264±0.010 (6.7±0.254)	0.035±0.010 (0.9±0.254)	0.065±0.010 (1.65±0.254)
	3	0.268±0.010 (6.8±0.254)	0.264±0.010 (6.7±0.254)	0.035±0.010 (0.9±0.254)	0.051±0.010 (1.3±0.254)

Model	SOLDER PAD DIMENSIONS - in inches (millimeters)			
	Resistance Range mΩ	a	b	i
SR2725-24	0.25 ~ 3	0.125(3.2)	0.27(6.9)	0.052(1.32)

Remark : 4 Watts with total solder pad trace size of 400 mm

4. Power Derating Curve :

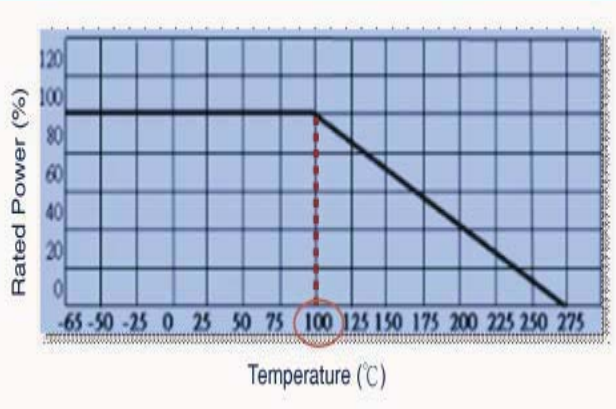

5. Performance :

Test Item	Conditions of test	Test Method	Test Limits
Short Time Overload	4W 4x rated power for 5 seconds	JIS C5202 5.5	$\pm(0.5\%+0.0005\Omega)\Delta R$
Resistance to Solder Heat	Solder temp./immersion time:260±5°C ,10±1secs and 350±10°C ,3.5±0.5secs	JIS C5202 6.4	$\pm(0.5\%+0.0005\Omega)\Delta R$
Solderability test	Steam aging:4 hrs, cool down 30 minutes then test	JIS C5202 6.5	95% coverage
Vibration	Frequency varied 55Hz in one minute , 3 directions , 12 hours	JIS C5202 6.7	$\pm(0.5\%+0.0005\Omega)\Delta R$
Resistance to solvent	Immersion time:60±5 secs,20°C ~25 °C	JIS C5202 6.9	$\pm(0.5\%+0.0005\Omega)\Delta R$
Mechanical Shock	100 grams for 6 milliseconds, 5 pulses	JIS C5202 6.13	$\pm(0.5\%+0.0005\Omega)\Delta R$
Low Temperature Storage	-55°C for 1000 hours	JIS C5202 7.1	$\pm(0.5\%+0.0005\Omega)\Delta R$
High Temperature Exposure	1000 hours @ + 155°C	JIS C5202 7.2	$\pm(1.0\%+0.0005\Omega)\Delta R$
Thermal Shock	- 55 °C to + 125 °C , 1000 cycles , 15 minutes at each extreme	JIS C5202 7.4	$\pm(0.5\%+0.0005\Omega)\Delta R$
Moisture Resistance	Mil-STD-202 , Method 106 , 0% power , 7a and 7b not required	JIS C5202 7.6	$\pm(0.5\%+0.0005\Omega)\Delta R$
Bias Humidity	+ 85°C , 85% RH, 10% Bias, 1000 hours,90 minutes "ON",30 minutes "OFF"	JIS C5202 7.9	$\pm(0.5\%+0.0005\Omega)\Delta R$
Load Life	1000 hours @ rated power, + 100°C , 1.5 hours "ON" , 0.5 hours "OFF"	JIS C5202 7.10	$\pm(1.0\%+0.0005\Omega)\Delta R$

6. Marking :



7. Packaging :

Model	Reel			
	Tape Width	Diameter	Pieces/Reel	Code
SR2725-24	12mm/Embossed Plastic	178mm/7"	1,000	1

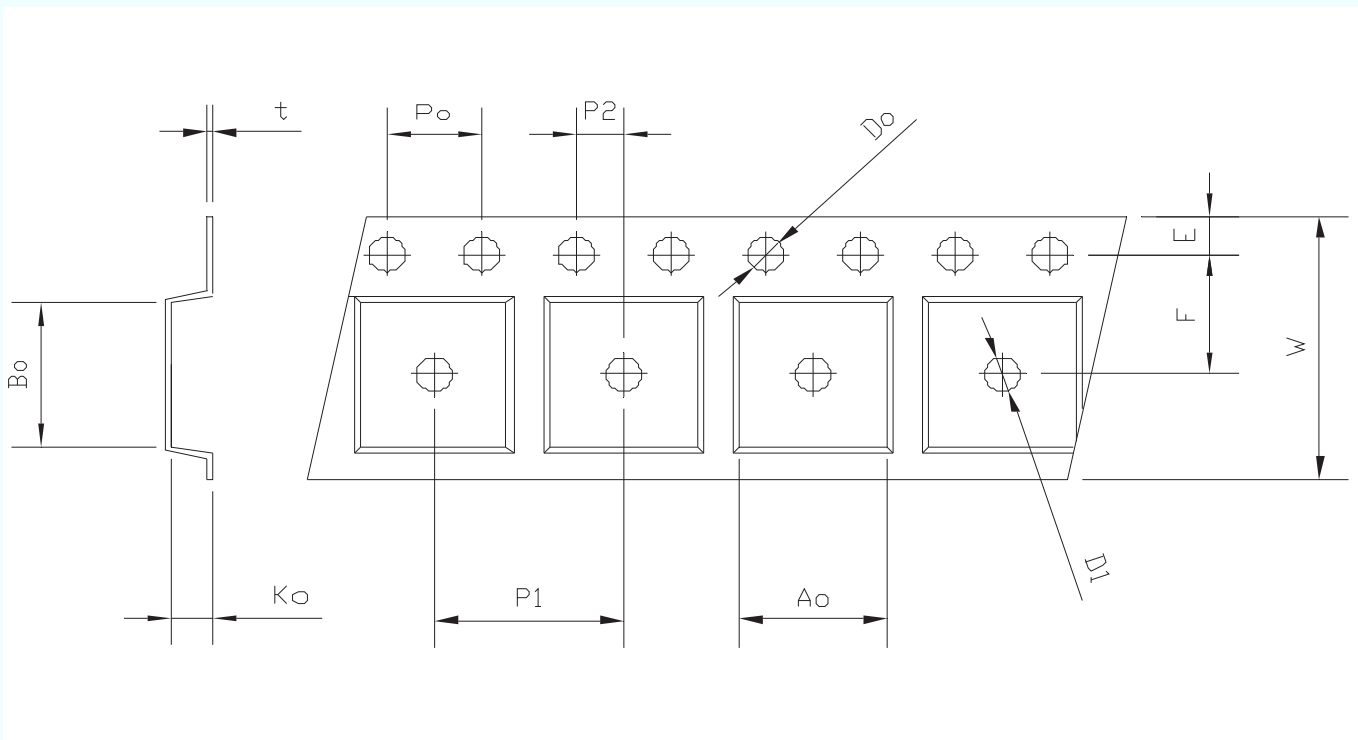

Unit: mm

Item	W	P1	E	F	Do	D1	P0	Po*10	P2	Ao	Bo	Ko	t
Spec.	12.00	8.00	1.75	5.50	1.50	1.50	4.00	40.00	2.00	7.15	6.75	1.70	0.25
Tole.	±0.15	±0.10	±0.10	±0.10	±0.05	±0.05	±0.10	±0.20	±0.10	±0.10	±0.10	±0.10	±0.05

T