



5V, 3.1A, 550KHz High Efficiency Low Ripple Synchronous Step-Up Converter

Description

The FP6717 is a high efficiency, fixed frequency 550KHz, current mode PWM boost DC/DC converter which could operate battery such as input voltage down to 2.5V. The converter output voltage can be adjusted to a maximum of 5.25V by an external resistor divider. Besides the converter includes a 39mΩ N-channel MOSFET switch and 42mΩ P-channel synchronous rectifier. So no external Schottky diode is required and could get better efficiency near 90%.

The converter is based on a fixed frequency, current mode, pulse-width-modulation PWM controller that goes automatically into PSM mode at light load.

When converter operation into discontinuous mode, the internal anti-ringing switch will reduce interference and radiated electromagnetic energy.

The FP6717 is available in a space-saving SOP-8 (Exposed Pad) package for portable application.

Features

- High Efficiency up to 90%
- Low $R_{DS(ON)}$ Integrated Power MOSFET
- NMOS 39mΩ/PMOS 42mΩ
- Wide Input Voltage Range: 2.5V to 5.25V
- Fixed 550KHz Switching Frequency
- Low-Power Mode for Light Load Conditions
- $\pm 2.0\%$ Voltage Reference Accuracy
- Adjustable Current Limit
- PMOS Current Limit for Short Circuit Protection
- Low Quiescent Current
- Input Under Voltage Lockout
- Internal Compensation Function
- Built-In Soft Start Function
- Over-Temperature Protection with Auto Recovery
- Output Overvoltage Protection
- SOP-8 (Exposed Pad) Pb-Free Package

Applications

- Portable Power Bank
- Wireless Equipment
- Handheld Instrument
- GPS Receiver

Pin Assignments

SP Package (SOP-8 Exposed Pad)

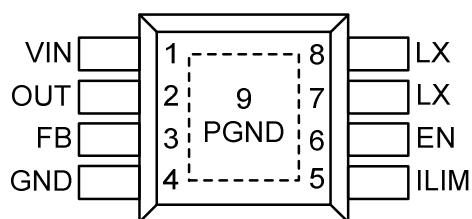
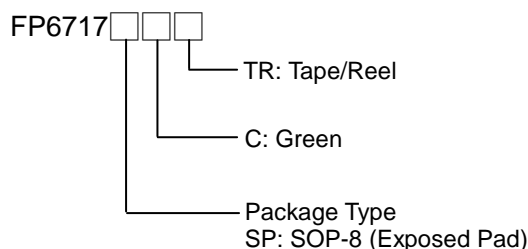

Figure 1. Pin Assignment of FP6717

Ordering Information



Typical Application Circuit

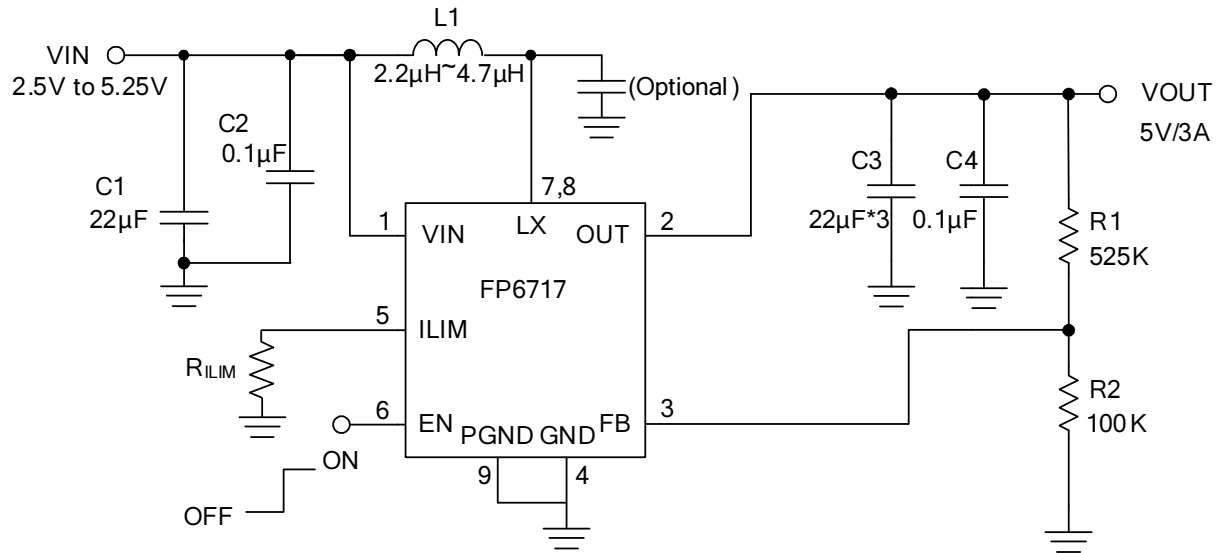
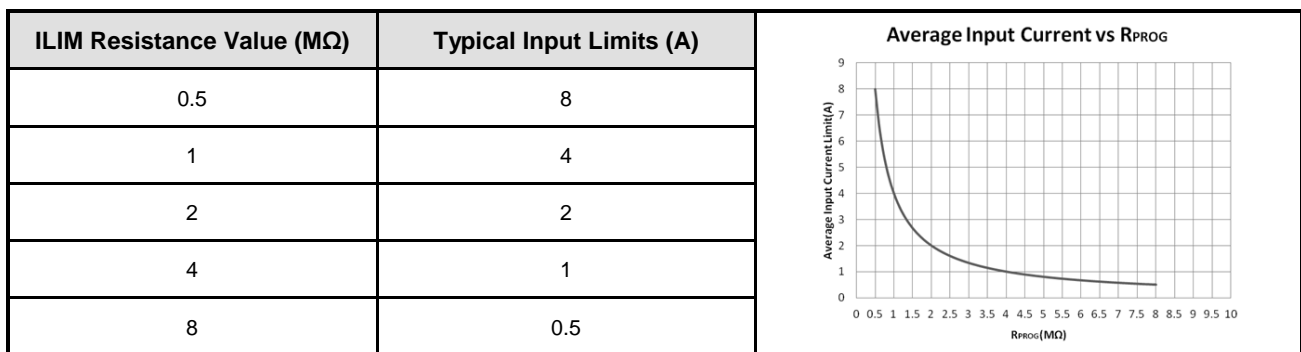

Figure 2. Typical Application Circuit



Functional Pin Description

Pin Name	Pin No.	Pin Function
VIN	1	Power Supply Input Pin.
OUT	2	Output of the Synchronous Rectifier.
FB	3	Voltage Feedback Input Pin.
GND	4	Ground Pin. Connect GND to exposed pad.
ILIM	5	Programming Input for Average Input Current.
EN	6	Logic Controlled Shutdown Input.
LX	7,8	Power Switching Connection. Connect LX to the inductor and output rectifier.
PGND	9	Power Ground Pin.

Block Diagram

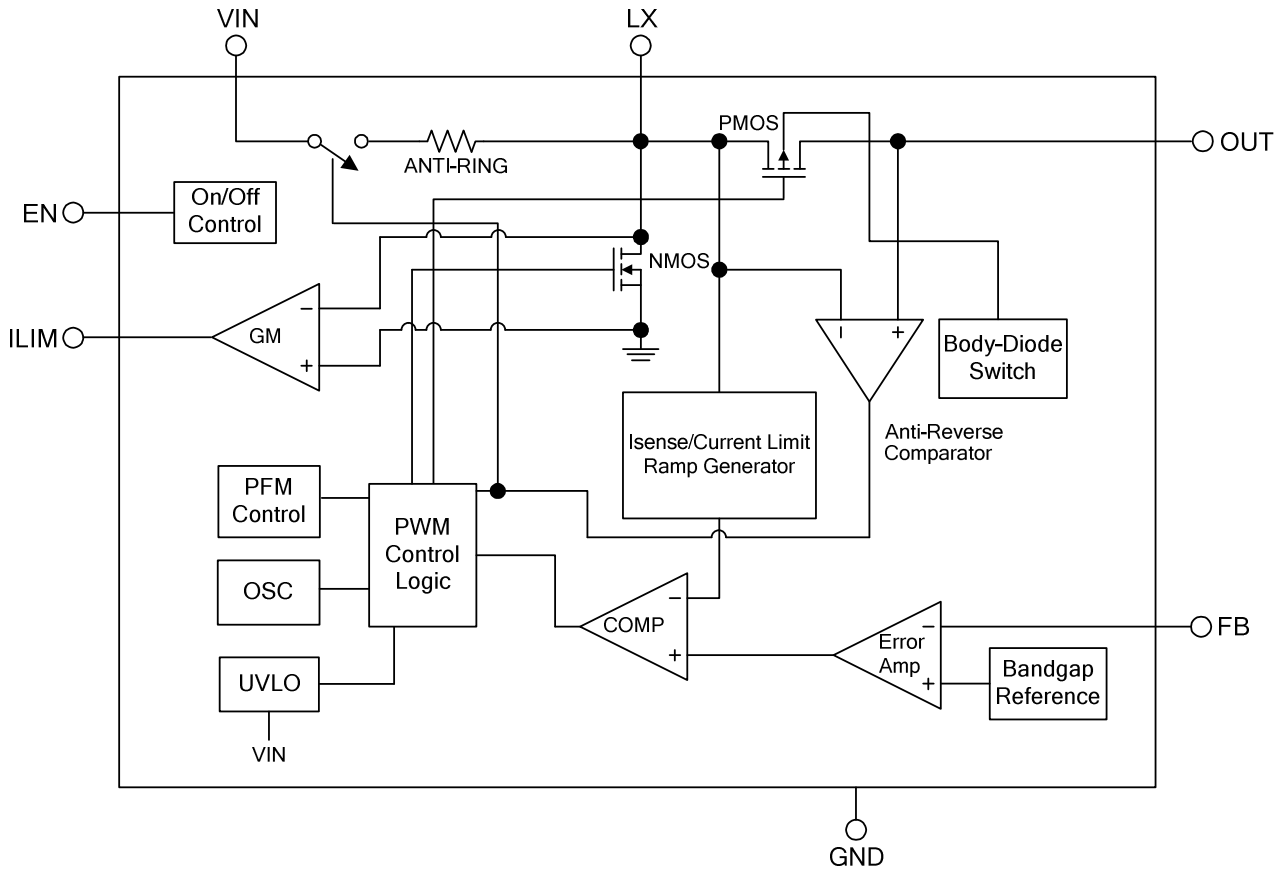

Figure 3. Block Diagram of FP6717

Absolute Maximum Ratings (Note 1)

- Supply Voltage V_{IN} ----- -0.3V to +6.5V
- LX Voltage V_{LX} ----- -0.3V to +6.5V
- All Other Pins Voltage ----- -0.3V to +6.5V
- Maximum Junction Temperature (T_J) ----- +150°C
- Storage Temperature (T_S) ----- -65°C to +150°C
- Lead Temperature (Soldering, 10sec.) ----- +260°C
- Package Thermal Resistance, (θ_{JA})
 - SOP-8 (Exposed Pad) ----- 60°C/W
- Package Thermal Resistance, (θ_{JC})
 - SOP-8 (Exposed Pad) ----- 15°C/W

Note 1 : Stresses beyond this listed under "Absolute Maximum Ratings" may cause permanent damage to the device.

Recommended Operating Conditions

- Supply Voltage V_{IN} ----- +2.5V to +5.25V
- Output Voltage Range ----- up to +5.25V
- Operation Temperature Range ----- -40°C to +85°C

Electrical Characteristics

($V_{IN}=3.3V$, $T_A=25^{\circ}C$, unless otherwise specified.)

Parameter	Symbol	Conditions	Min	Typ	Max	Unit
VIN Input Supply Voltage	V_{IN}		2.5		5.25	V
VIN Supply Current (Switching)		$V_{IN}=3.3V$, $V_{FB}=0.7V$ Measure V_{IN}		300	500	μA
VIN Supply Current (No witching)		$V_{FB}=1V$		45		μA
Feedback Voltage	V_{FB}	$2.5V \leq V_{IN} \leq 5.5V$	0.784	0.8	0.816	V
High-Side PMOSFET $R_{DS}(ON)$				42		m Ω
Low-Side NMOSFET $R_{DS}(ON)$				39		m Ω
High-Side MOSFET Leakage Current	$I_{LX(leak)}$	$V_{LX}=5.5V$, $V_{OUT}=0V$			10	μA
Low-Side MOSFET Leakage Current		$V_{LX}=5.5V$			10	μA
Oscillation Frequency	F_{OSC}		450	550	650	KHz
Short Circuit Trip Point		Monitored FB voltage		0.3		V
Short Circuit Current Limit		$V_{IN} = 3.3V$		50		mA
Maximum Duty Cycle	D_{MAX}	$V_{IN}=3.3V$	90			%
ILIM Current		$R_{ILIM}=500K$		8		A
ILIM Current Gain		$V_{IN}=3.3V$		8		M Ω -A/A
Line Regulation		$V_{IN}=2.5V$ to $5.5V$, $I_{OUT}=100mA$			1	%
Load Regulation		$I_{OUT}=0A$ to $1A$		0.5		%
Input UVLO Threshold	$V_{UVLO(VTH)}$	V_{IN} Rising		2.3		V
Under Voltage Lockout Threshold Hysteresis	$V_{UVLO(HYS)}$	V_{IN} Falling		250		mV
OVP Threshold Voltage on OUT Pin				5.7		V
OVP Threshold Hysteresis				350		mV
Internal Soft-Start Time				1	3	ms
EN Input Low Voltage	$V_{EN(L)}$				0.4	V
EN Input High Voltage	$V_{EN(H)}$		1.4			V
EN Input Current	I_{EN}	$V_{IN}=3.3V$		2		μA
Thermal Shutdown Threshold (Note 2)	TSD			150		$^{\circ}C$
Thermal Shutdown Hysteresis				30		$^{\circ}C$

Application Information (Continued)

(1) Programming the Output Voltage

The output voltage of the FP6717 can be adjusted with an external resistor divider. The typical value of the voltage on the FB pin is 800mV in fixed frequency operation. The maximum allowed value for the output voltage is 5.5V. The current through the resistive divider should be about 100 times greater than the current into the FB pin. The typical current into the FB pin is 0.01μA, and the voltage across R2 is typically 800mV. Based on those two values, the recommended value for R2 is in the range of 800kΩ in order to set the divider current at 1μA. From that, the value of resistor R1, depending on the needed output voltage (V_o), can be calculated using Equation 1.

$$R1=R2 \times \left(\frac{V_{OUT}}{V_{FB}} - 1 \right) = 800k\Omega \times \left(\frac{V_{OUT}}{800mV} - 1 \right) \dots\dots(1)$$

(2) Inductor Selection

A boost converter normally requires two main passive components for storing energy during the conversion. A boost inductor is required and a storage capacitor at the output. To select the boost inductor, it is recommended to keep the possible peak inductor current below the current limit threshold of the power switch in the chosen configuration.

The second parameter for choosing the inductor is the desired current ripple in the inductor. Normally, it is advisable to work with a ripple of less than 20% of the average inductor current. A smaller ripple reduces the magnetic hysteresis losses in the inductor, as well as output voltage ripple and EMI. But in the same way, regulation time at load changes rises. In addition, a larger inductor increases the total system cost. With those parameters, it is possible to calculate the value for the inductor by using Equation 2.

$$L = \frac{V_{IN} \times (V_{OUT} - V_{IN})}{\Delta I_L \times f \times V_{OUT}} \dots\dots(2)$$

Parameter f is the switching frequency and ΔI_L is the ripple current in the inductor, i.e, 20% x I_L. With this calculated value and currents, it is possible to choose a suitable inductor. Care must be taken that load transients and losses in the circuit can lead to higher currents. Also, the losses in the inductor caused by magnetic hysteresis losses and copper losses are a major parameter for total circuit efficiency.

(3) Capacitor Selection

The major parameter necessary to define the output capacitor is the maximum allowed output voltage ripple of the converter. This ripple is determined by two parameters of the capacitor, the capacitance and the ESR. It is possible to calculate the minimum capacitance needed for the defined ripple, supposing that the ESR is zero, by using Equation 3.

$$C_{MIN} = \frac{I_{OUT} \times (V_{OUT} - V_{IN})}{f \times \Delta V \times V_{OUT}} \dots\dots(3)$$

Parameter f is the switching frequency and ΔV is the maximum allowed ripple.

The total ripple is larger due to the ESR of the output capacitor. This additional component of the ripple can be calculated using Equation 4.

$$\Delta V_{ESR} = I_{OUT} \times R_{ESR} \dots\dots(4)$$

The total ripple is the sum of the ripple caused by the capacitance and the ripple caused by the ESR of the capacitor. It is possible to improve the design by enlarging the capacitor or using smaller capacitors in parallel to reduce the ESR or by using better capacitors with lower ESR, like ceramics. Tradeoffs must be made between performance and costs of the converter circuit.

A 10μF input capacitor is recommended to improve transient behavior of the regulator. A ceramic or tantalum capacitor with a 100nF in parallel placed close to the IC is recommended.

Outline Information

SOP-8 (Exposed Pad) Package (Unit: mm)

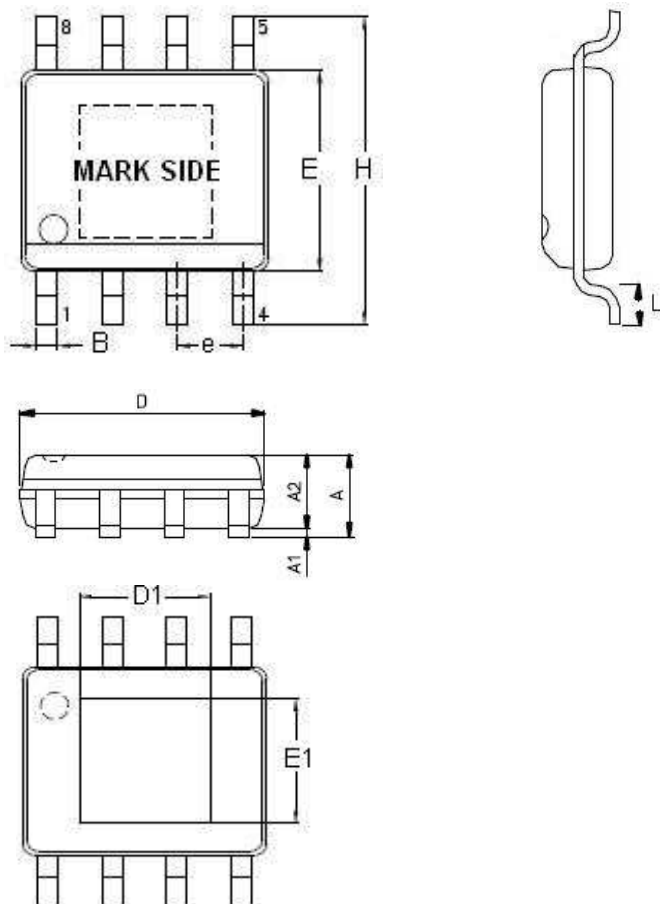

SYMBOLS UNIT	DIMENSION IN MILLIMETER	
	MIN	MAX
A	1.25	1.70
A1	0.00	0.15
A2	1.25	1.55
B	0.31	0.51
D	4.80	5.00
D1	3.04	3.50
E	3.80	4.00
E1	2.15	2.41
e	1.20	1.34
H	5.80	6.20
L	0.40	1.27

Note : Followed From JEDEC MO-012-E.

Carrier Dimensions

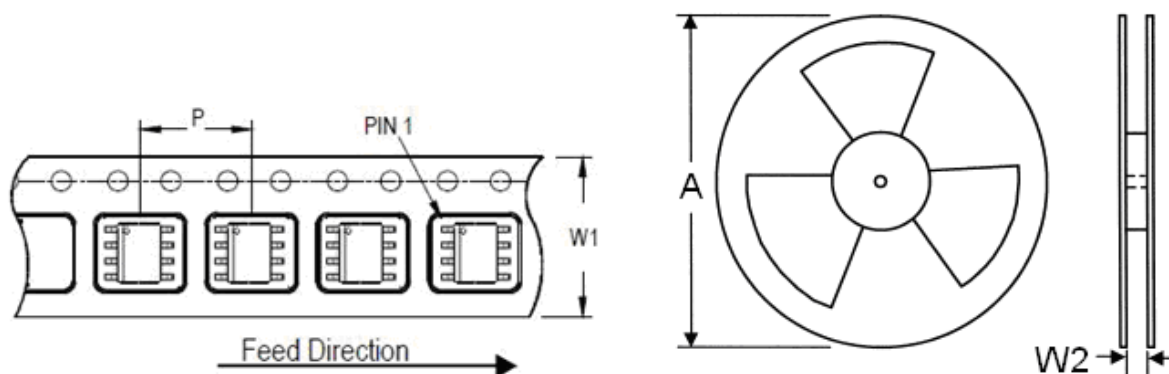

Tape Size (W1) mm	Pocket Pitch (P) mm	Reel Size (A)		Reel Width (W2) mm	Empty Cavity Length mm	Units per Reel
		in	mm			
12	8	13	330	12.4	400~1000	2,500

Life Support Policy

Fitipower's products are not authorized for use as critical components in life support devices or other medical systems.