

Features

- ◆ Able to withstand high temperature and high current
- ◆ Ultra Low sensing resistance
- ◆ Excellent frequency response
- ◆ Chip size: 0805, 1206, 2512 and 3720
- ◆ Lead free, RoHS compliant for global applications and halogen free

Application

- ◆ Mobile electronic equipment-Cellular phone, NB Tablet PC, GPS, DSC, HDD
- ◆ DC-DC converter, Adapter, Battery pack and charger
- ◆ Switching power supply
- ◆ Voltage Regulation module
- ◆ Power management applications

Part Numbering System

<u>SR</u>	<u>G</u> <u>FG</u>	<u>R010</u>	<u>F</u>	<u>E</u>	<u>E</u>
(1)	(2)	(3)	(4)	(5)	(6)

- (1) Series Code
- (2) Size (EIA): Length x Width
- (3) Resistance: R002=2mΩ, R010=10mΩ
- (4) Tolerance: D=±0.5%, F=±1%, G=±2%, J=±5%
- (5) Power Rating: S=1/2W, C=1W, D=1.5W, E=2W, R=3W
- (6) Packaging: T- Embossed paper tape, 7" reel
E-Embossed plastic tape, 7" reel

Dimension

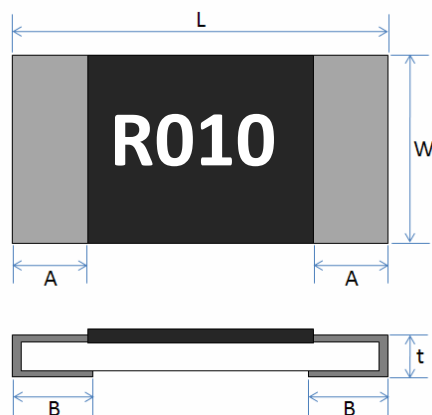

Type (inch size)	Dimensions(mm)				
	L	W	t	A	B
SR0805	2.00±0.15	1.25±0.15	0.65±0.15	0.40±0.20	0.35±0.20
SR1206(S)	3.10±0.20	1.55±0.10	0.65±0.15	0.50±0.20	0.50±0.20
SR1206(L)					1.00±0.30
SR2512(S)	6.40±0.20	3.20±0.20	0.80±0.15	0.90±0.20	1.10±0.25
SR2512(L)					2.10±0.25
SR2725	7.10±0.25	6.30±0.25	0.65±0.15	0.85±0.2.5	1.90±0.25

*Remark: $R \leq 3m\Omega$ is L Type

●All Specifications are subject to change without notice.

Electrical Specification

Item	Power Rating	Resistance Range(mΩ)	Operation Temp. Range	TCR (PPM/°C)
SR0805	1/2W	$10 < R \leq 50$	-55~+170°C	±50
		10		±100
SR1206	1/2W, 1W	$10 < R \leq 100$		±50
		$5 \leq R \leq 10$		±100
SR2512	1W, 1.5W, 2W, 3W	$10 \leq R \leq 200$		±50
		$1 \leq R < 10$		±100
SR2725	3.5W, 4W	$0.5 \leq R \leq 79$		±50
		$3 \leq R < 100$		±100

Derating Curve

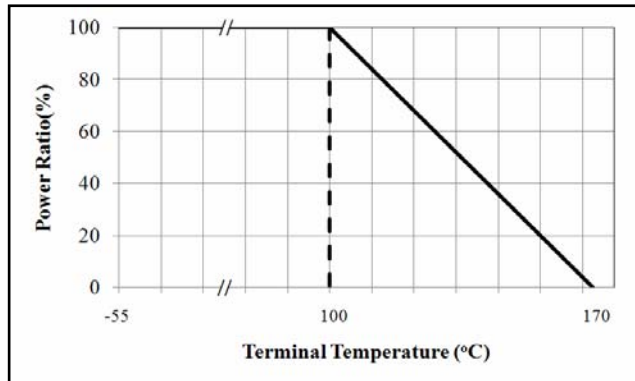

Construction

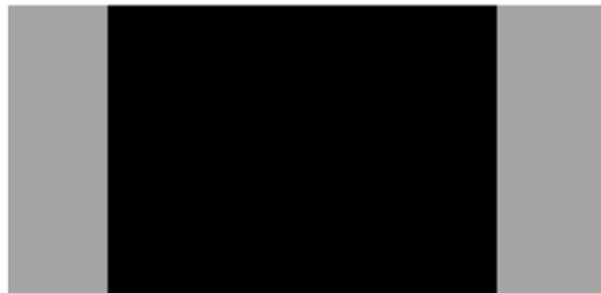

Top view

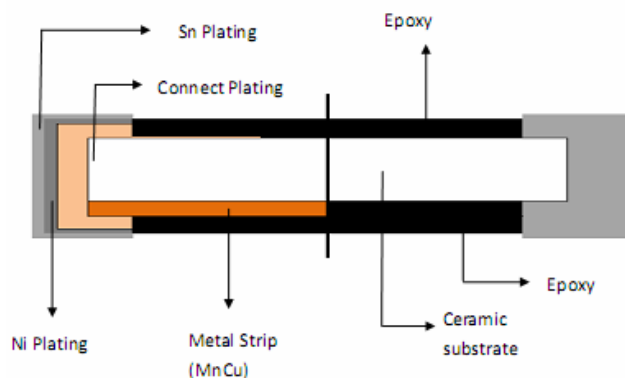

Side view

•All Specifications are subject to change without notice.

Performances
Environmental Performance

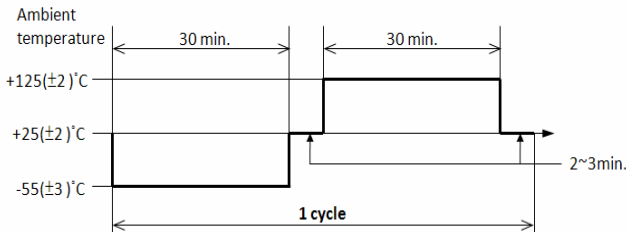
No.	Item	Test Condition	Specification
1	Short Time Overload	Voltage equal to 5 time rated power for 5 sec , (JIS-C5202-5.5)	$\Delta R: \pm(1\%+0.0005\Omega)$
2	Temperature Coefficient of Resistance (T.C.R.)	+25°C /+125°C. (JIS-C5202-5.2) $TCR \text{ (ppm/}^\circ\text{C)} = \frac{\Delta R}{R \times \Delta t} \times 10^6$	Refer to Electrical Specification
3	Damp Heat with Load	The specimens shall be placed in a chamber and subjected to a relative humidity of 90~95% percent and a temperature of 40° ±2°C for the period of 1000 hrs. (MIL-STD-202, Method 103)	$\Delta R: \pm(1\%+0.0005\Omega)$
4	High Temperature Exposure	The ship (mounted on board) is exposed in the heat chamber 125±3°C for 1000 hrs. (JIS-C5202-7.2)	$\Delta R: \pm(1\%+0.0005\Omega)$
5	Load Life	Apply rated power at 70±2°C for 1000 hours with 1.5 hours ON and 0.5 hour OFF. (JIS-C5202-7.10)	$\Delta R: \pm(1\%+0.0005\Omega)$
6	Rapid change of temperature	The chip (mounted on board) is exposed, -55±3°C (30min.)/+125±2°C (30min.) for 5 cycles. The following conditions as the following figure. (JIS-C5202-7.4) 	$\Delta R: \pm(1\%+0.0005\Omega)$

•All Specifications are subject to change without notice.

Function Performance

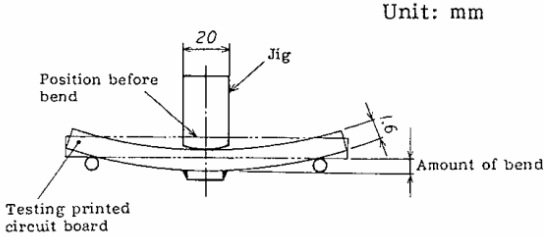
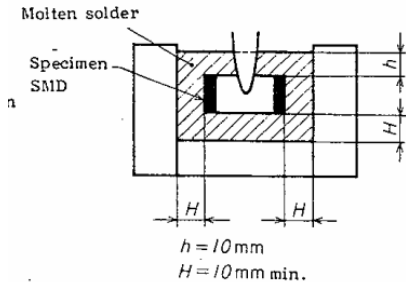
No.	Item	Test Condition	Specification
1	Bending Strength	<p>Mount the chip to test substrate. Apply pressure in direction of arrow unit band width reaches 2mm(+0.2/-0mm) illustrated in the figure below and hold for 10±1 sec. (JIS-C5202-6.1)</p> <p style="text-align: right;">Unit: mm</p> 	ΔR: ±(1%+0.0005Ω)
5	Solvent Resistance	<p>The chip is completed immersion of the specimens in the isopropyl alcohol for 3 *+5, -0) min., 25°C ±5°C. ((MIL-STD-202, Method 215)</p>	Verify marking permanency. (Nor required for laser etched parts or parts with no marking)
6	Resistance to solder Heat	<p>The specimen chip shall be immersed into the flux specified in the solder bath 260±5°C for 10±1 sec. (MIL-STD-202, Method 210)</p>	ΔR: ±(1%+0.0005Ω)
7	Solderability	<p>The specimen chip shall be immersed into the flux specified in the solder bath 235±5°C for 2±0.5 sec. It shall be immersed to a point 10mm from its root. (Sn96.5/Ag3.0/Cu0.5) (JIS-C5 202-6.11)</p> 	Solder shall be covered 95% or more of the electrode area.

Remark:

- 0.5 W with total solder pad trace size of 100 mm².
- 1.0 W with total solder pad trace size of 100 mm².
- 1.5 W with total solder pad trace size of 200 mm².
- 2.0 W with total solder pad trace size of 300 mm².

●All Specifications are subject to change without notice.

Tape Packaging Specifications

◆Paper Tape Specifications

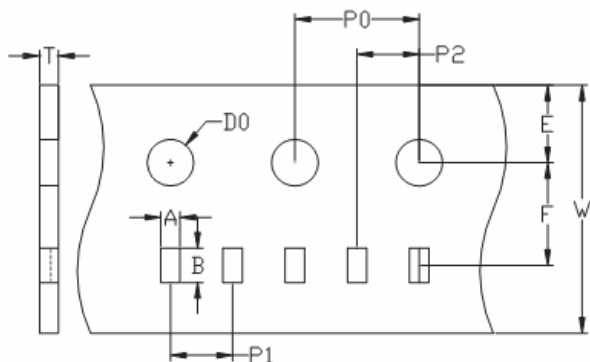

Unit:mm

Type	Carrier Dimensions									
	A	B	E	F	W	P0	P1	P2	D0	T
0805	1.6±0.1	2.4±0.1	1.75±0.1	3.5±0.05	8.0±0.2	4.0±0.1	4.0±0.1	2.0±0.05	1.55±0.05	0.97±0.1
1206	2.0±0.1	3.6±0.1	1.75±0.1	3.5±0.05	8.0±0.2	4.0±0.1	4.0±0.1	2.0±0.05	1.55±0.05	0.97±0.1

◆Embossed Plastic Tape Specifications

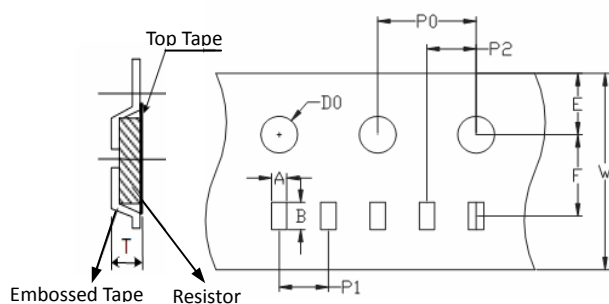

Unit:mm

Type	Carrier Dimensions									
	A	B	E	F	W	P0	P1	P2	D0	T
2512	3.5±0.1	6.8±0.1	1.75±0.1	5.5±0.05	12.0±0.2	4.0±0.05	4.0±0.1	2.0±0.05	1.5±0.1	1.0±0.2
2725	2.6±0.2	4.5±0.2	1.75±0.1	5.5±0.05	12.0±0.2	4.0±0.05	4.0±0.1	2.0±0.05	1.5±0.1	1.0±0.2

Packaging

Size EIA (EIAJ)	0805/1206	2512/2725
Standard Packing Quantity (pcs /reel)	5,000	2,000/1,000

◆All Specifications are subject to change without notice.

Storage Conditions

Temperature : 5~35°C, Humidity : 40~75%

Recommended Solder Pad Layout

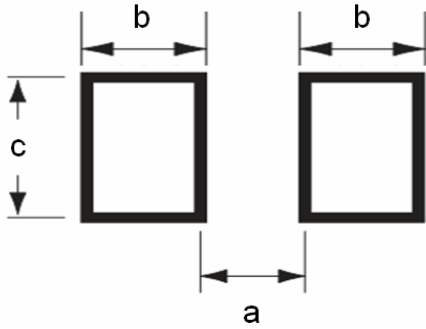

Type	Pad Layout Dimension (mm)		
	a	b	c
0805	1.20	1.20	1.20
1206	2.20	1.30	1.80
2512	3.80	2.10	3.40
2725	3.14	2.2	7.2

Soldering Recommendations

- ◆ Peak reflow temperatures and durations :
 - IR Reflow Peak = 260°C max for 10 sec
 - Wave Solder = 260°C max for 10 sec
- ◆ Compatible with lead and lead-free solder reflow processes
- ◆ Recommended IR Reflow Profile :

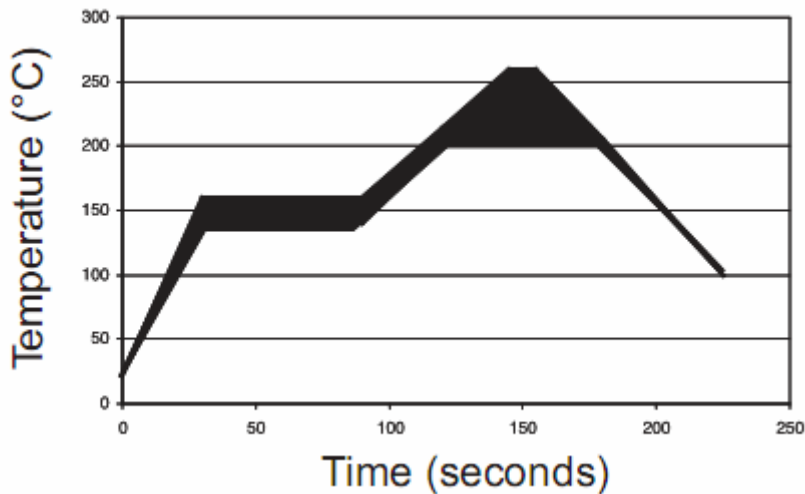

ECN

Engineering Change Notice : The customer will be informed with ECN if there is significant modification on the characteristics and materials described in Approval Sheet.

•All Specifications are subject to change without notice.