



# IML8683- 交流分段線性驅動核心

2014/ 02





- iML公司簡介
- IML8683 產品介紹
- 交流分段驅動產品發展規劃



# iML 公司簡介

## 基本資料

- 成立於1996
- 台灣上市公司( #3638)
- 總部: 美國San Jose
- 於台灣、韓國、中國、香港、日本等地設有研發/營運/銷售據點
- 年營業額: USD100M (2012)
- 員工人數: 114人

## iML主要客戶



## 產品

iML致力於開發應用於顯示器(LCD與OLED電視, 平板, 筆記型電腦與顯示器)、LED照明與車用之各式類比、電源管理與數位/類比混和型積體電路

### High Voltage Analog & Mixed-Signal

- Programmable-Gamma Buffers
- Vcom Buffers
- Digital Voltage Reference (DVR)

### Power Management ICs

- DC/DC and Power Management ICs
- Level Shifters
- WLED Backlight Drivers

### Growth Products

- LED Lighting AC Step-drivers
- TVS/ESD Circuit Protectors
- Optical Sensors (ALS, Proximity and Gesture Sensors)

**iML's parts are  
designed into  
all major tablets**



# 公司發展歷程與後續規劃

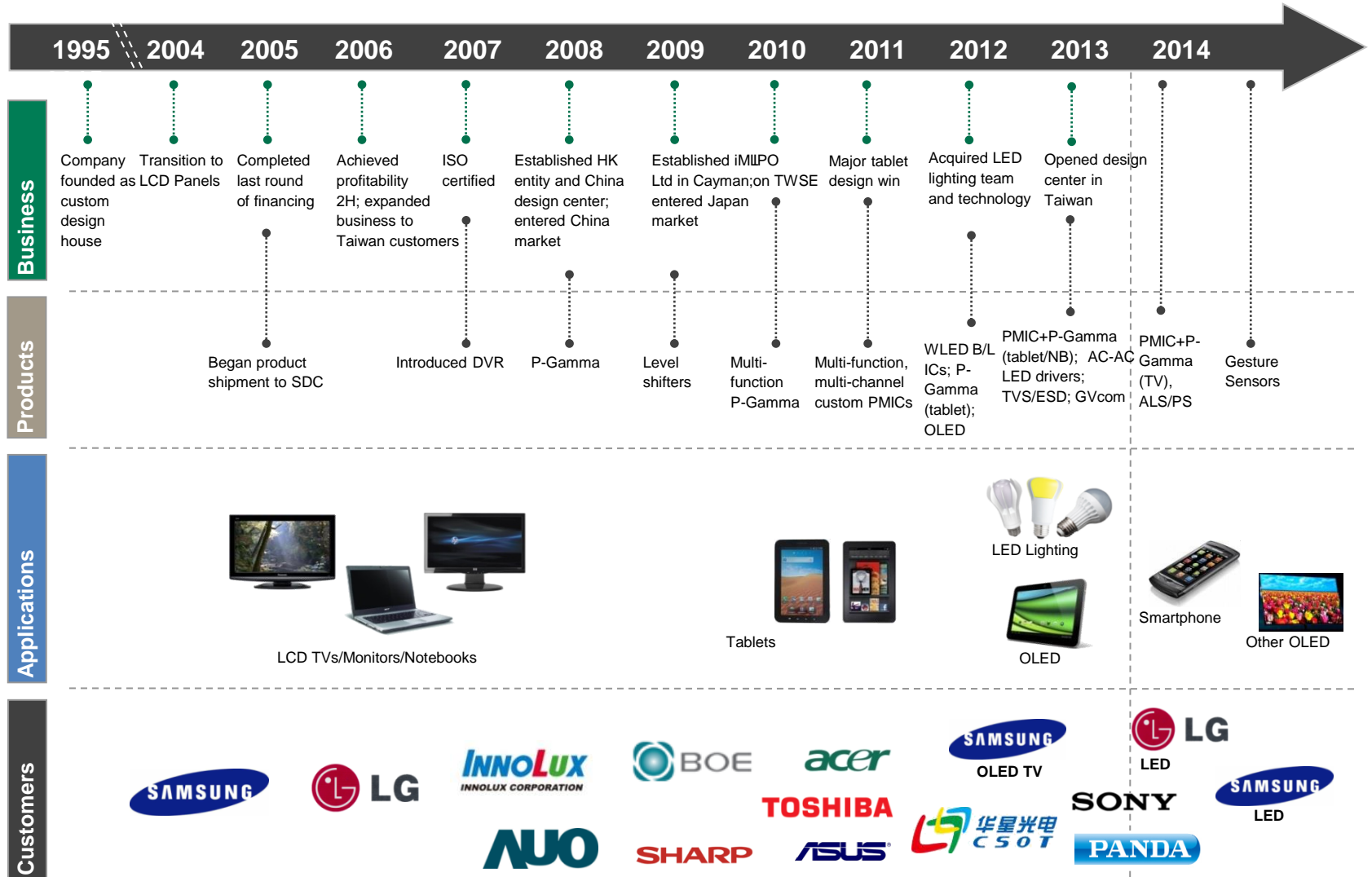

LCD TVs/Monitors/Notebooks



Tablets



LED Lighting



OLED



Smartphone



Other OLED



- ① 貼近客戶端設立營業據點, 提供客戶強而有力的設計支援
- ② 研發與工程據點鄰近供應商, 提高技術開發與整合能力並確保貨源
- ③ **Fabless**營運模式, 結合專業晶圓代工廠廠與封測廠, 降低資本支出並獲得最佳成本結構
- ④ 採用具成本優勢之 8" 晶圓進行生產, 主要供應商包括 **UMC, MagnaChip, 以及 Vanguard**





- iML公司簡介
- IML8683產品介紹
- 交流分段驅動產品發展規劃



# iML8683- 交流分段驅動核心

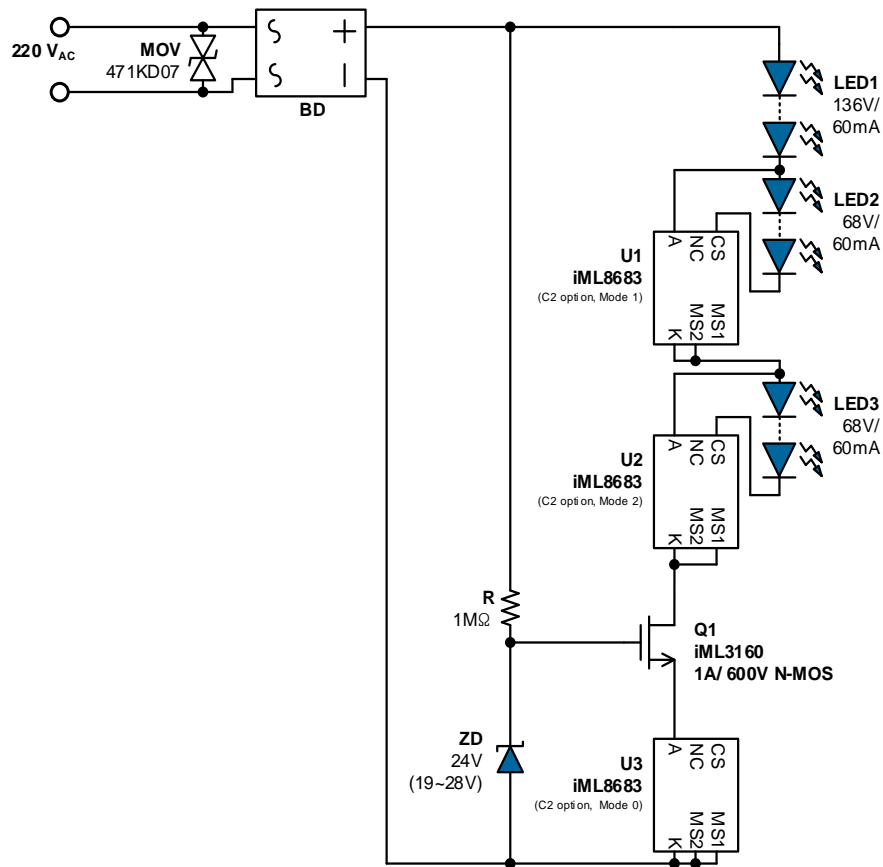

## iML8683驅動系統特點:

- 單一線路可驅動7~14W
- PF > 0.98, THD < 20% (三階)
- 可調光
- 符合各項規範(EMI, THD, 雷擊測試)
- 小型化, 無需使用電解電容

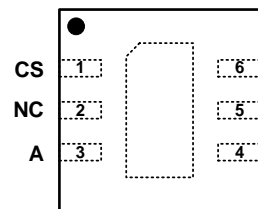
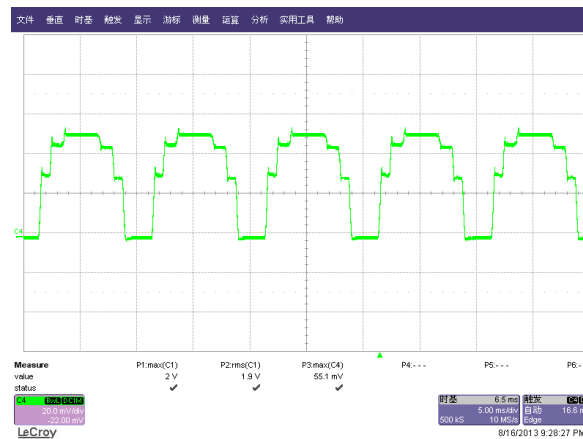

DFN- 2mmx2mm-6L

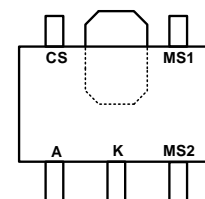

SOT-89- 5L



# LED照明驅動市場趨勢



需求		驅動方案		線性驅動	
		非隔離	隔離	AC LED	iML 8683
1	成本	○	△	◎	○
2	小尺寸化	○	△	◎	◎
3	元件數量	△	△	◎	○
4	功率因素Power Factor > 0.9	◎	◎	△	◎
5	無電解電容	○	△	◎	◎
6	效率 >80%	○	△	△	○
7	TRIAC調光	◎	◎	○	○
8	THD < 30%	○	◎	△	○
9	頻閃	△	○	△	△
10	線性調整率 (Line Regulation)	◎	◎	△	△

◎: 優良    ○: 佳    △: 待改進





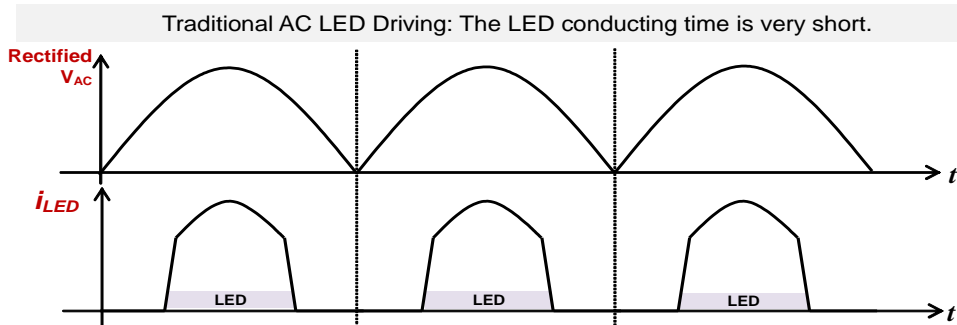
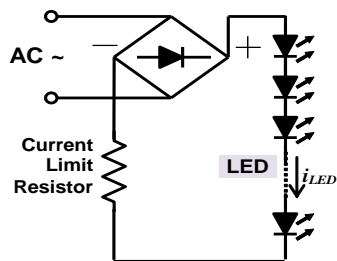
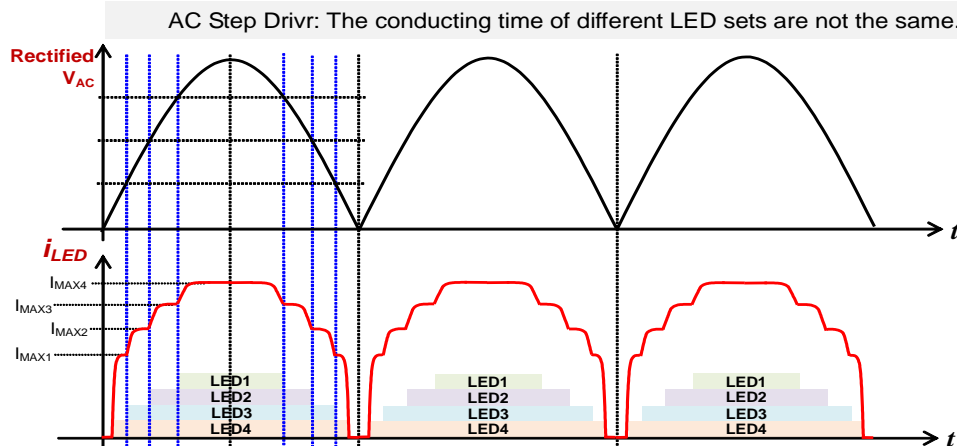
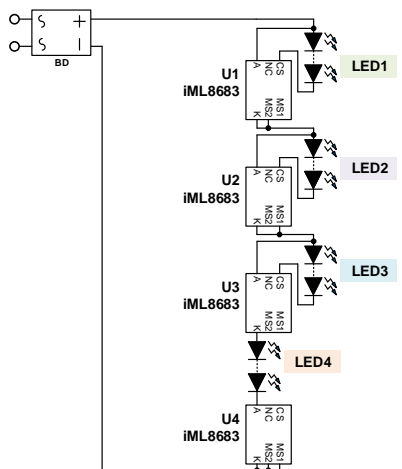
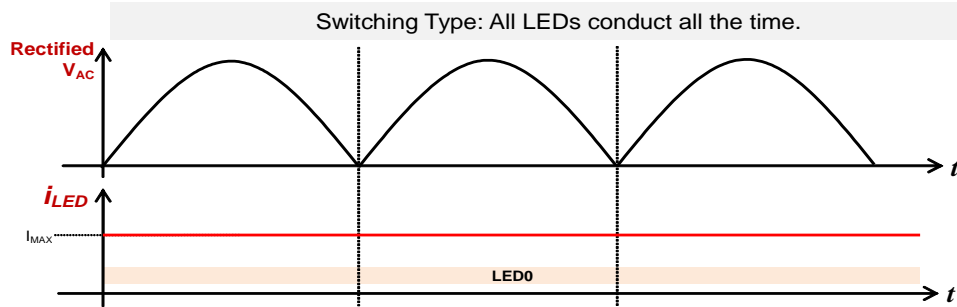
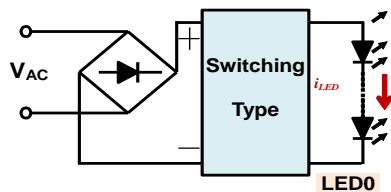

## 低壓解決方案

使用一般晶圓製程即可 (40V~80V)

US Patent: 8,288,960

Filed: Apr 15, 2010

Assignee: IML International

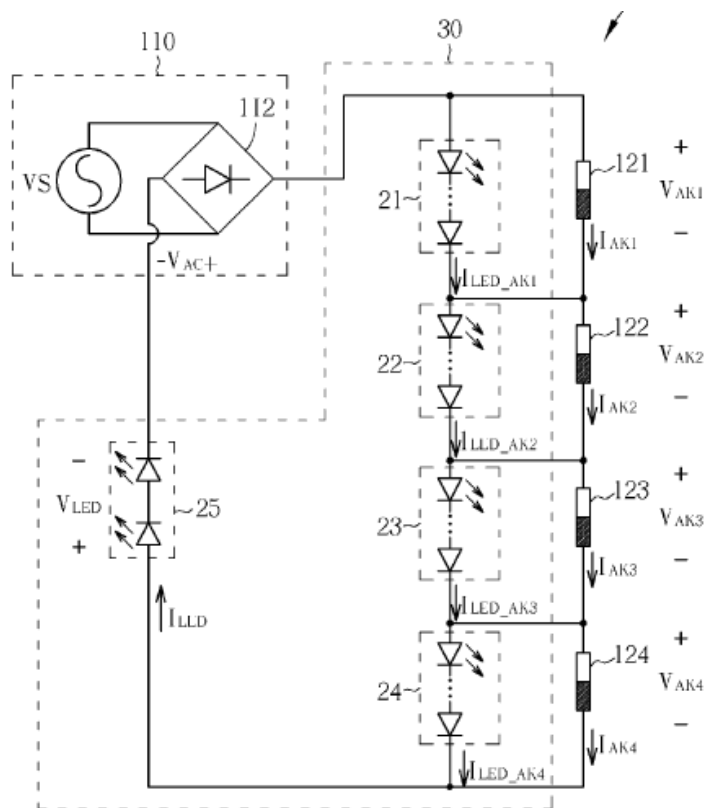

IML特有專利19件 (7件已取得)

## 高壓解決方案

需使用高壓晶圓製程 (400V~700V)

US Patent: 6,989,807

Filed: May 19, 2003

Assignee: Koninklijke Philips Electronics

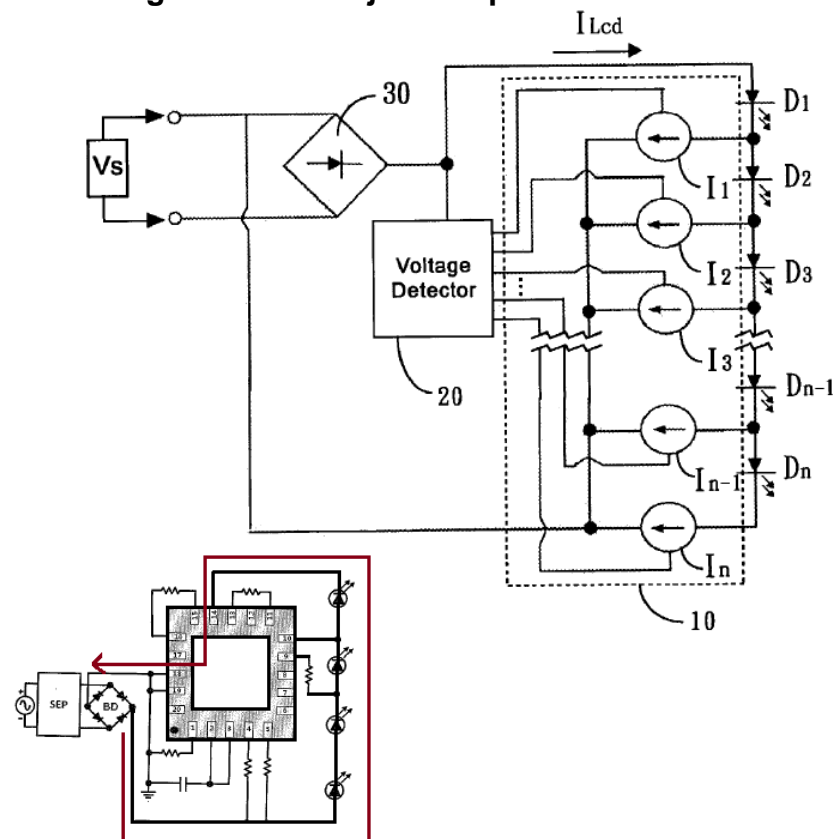

## ■ 與切換式電源相較:

1. 實現全固態照明, 包含**LED**與驅動器皆為固態元件
2. 光引擎與驅動器之完美整合, 達成小型化
3. 無需使用電解電容
4. 在相同規格下具成本優勢

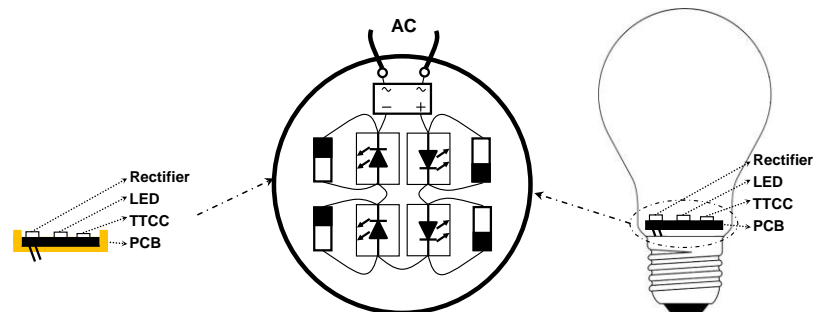

iML LED Driver ICs on Light Engine

## ■ 與高壓驅動系統相較:

1. 易於使用**COB**製程
2. 具生產彈性, 在相同設計下, 可依據客戶規格要求與成本需求, 分別生產不同規格成品(一階~三階)
3. 易於**PCB**布局, 尤其在燈管應用
4. 將熱分散在各個元件, 以利於散熱並提高光引擎功率(單一組可驅動至**7~14W**)





# iML8683 可符合各種不同應用需求

## TRIAC 調光架構

Leading edge, Tailing edge

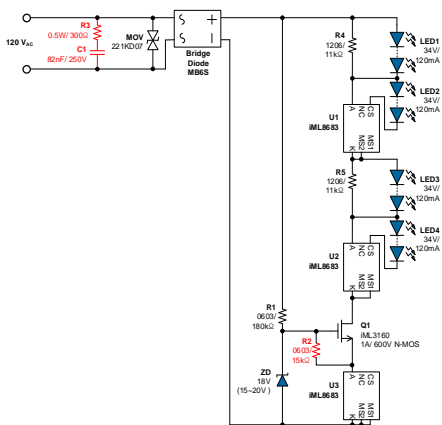

## 低成本架構

PF=0.96, THD <30%

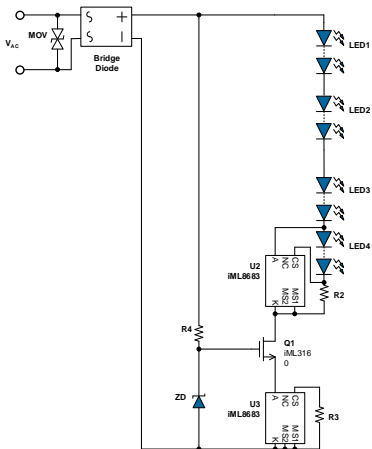

## 線路簡單且具有彈性

### 基本架構

7W~14W, Efficiency 85~90%  
PF=0.98, THD <20%  
Surge 1000V, System ESD 4000V  
Pass EMI, Current Harmonics

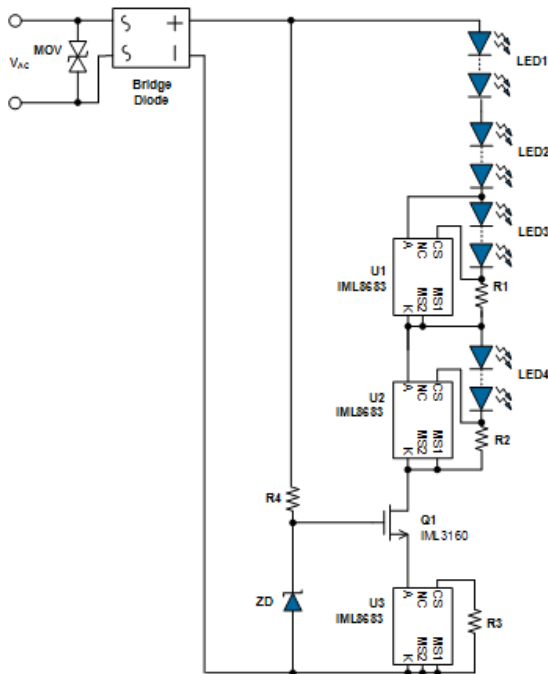

## 低頻閃, 高光效架構

Percent Flicker 30%, Flicker Index 0.1

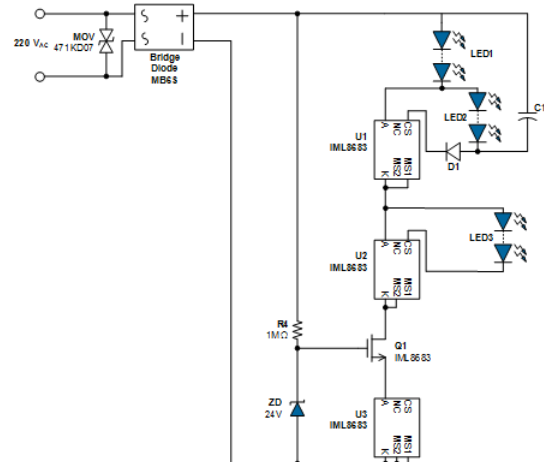

## 平衡點亮架構

各段LED亮度差異 <20%

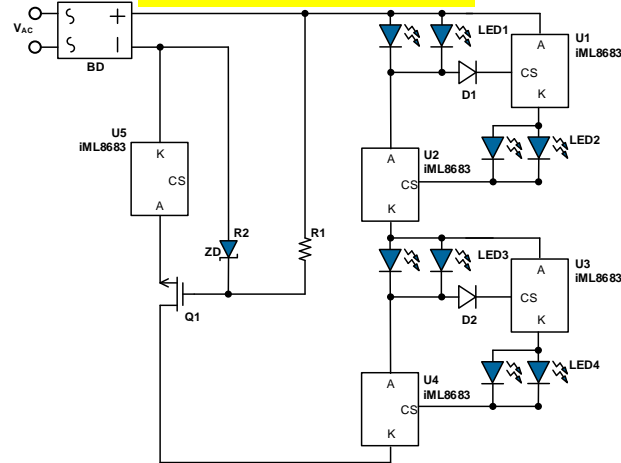

## 220VAC/ 10W

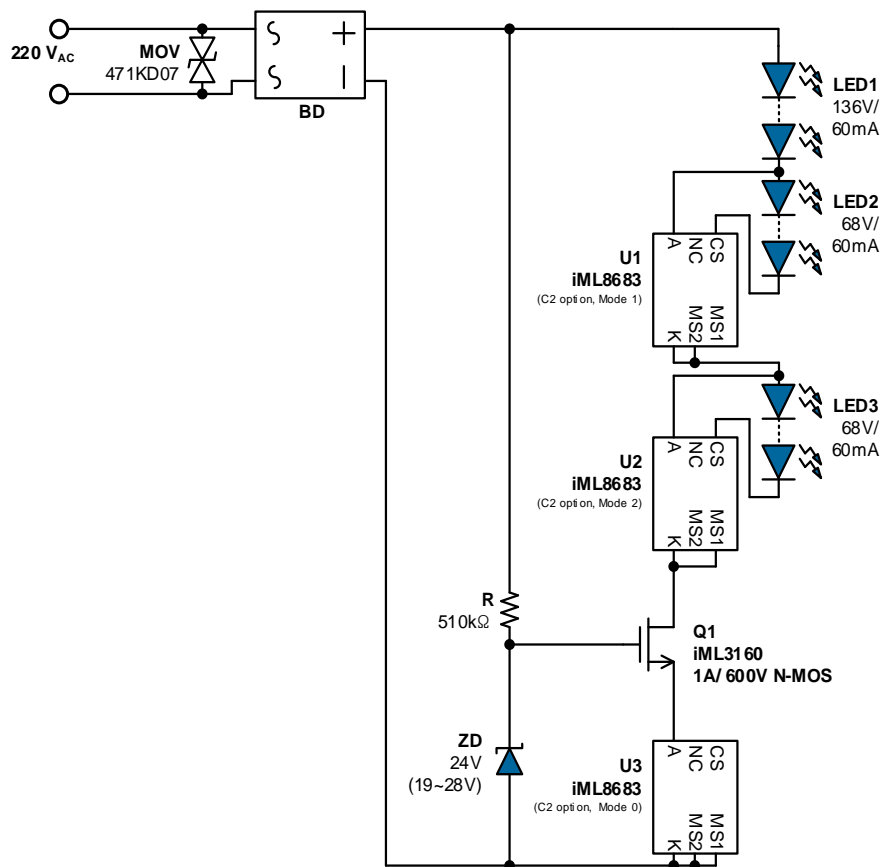

## 110VAC/ 10W

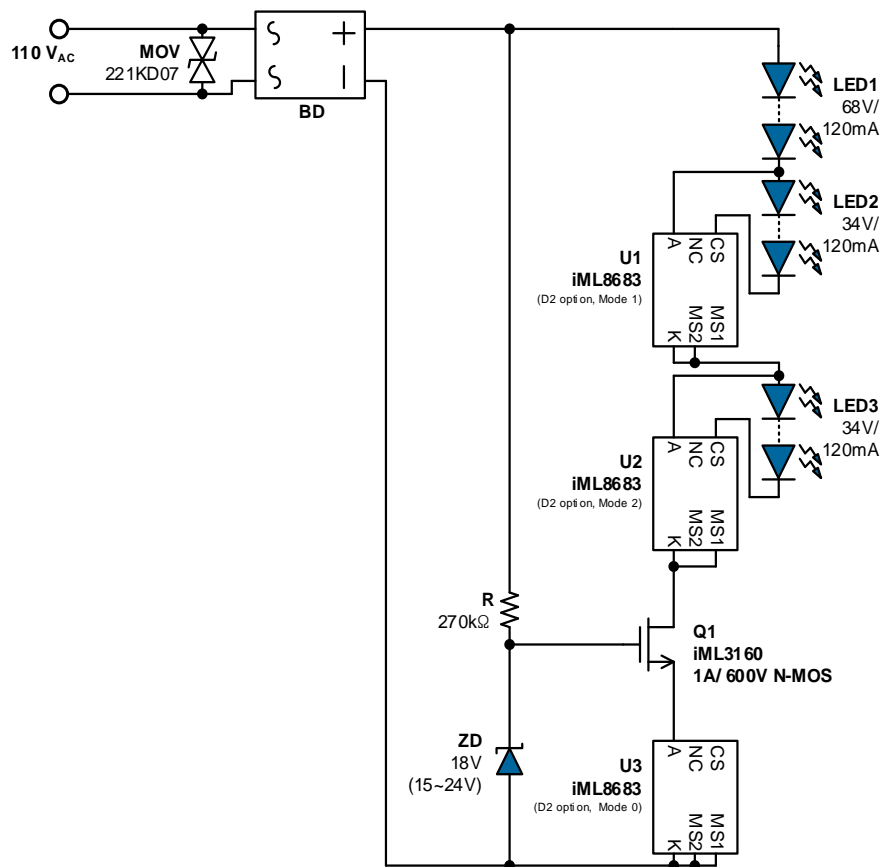

註: 在未使用壓敏電阻(MOV)的情形下, 可通過750V雷擊(浪湧)測試, 增加壓敏電阻可進一步提升到1kV雷擊測試(IEC61000-4-5).



## 整串LED $V_F$ 要求

最佳設計建議:

**Rectified VAC, Nominal x 83% < LED Total VF < Rectified VAC, Nominal x 89%**

交流電壓 (rms)		整流後峰值電壓	建議 LED $V_F$
100V <sub>AC</sub>	110V (MAX.)	156V	117~125V
	100V (TYP.)	141V	
	90V (MIN.)	127V	
110V <sub>AC</sub>	121V (MAX.)	171V	129~138V
	110V (TYP.)	156V	
	99V (MIN.)	140V	
120V <sub>AC</sub>	132V (MAX.)	187V	140~151V
	120V (TYP.)	170V	
	108V (MIN.)	153V	
220V <sub>AC</sub>	242V (MAX.)	342V	258~277V
	220V (TYP.)	311V	
	198V (min.)	280V	



# IML8683 驅動系統參數 (220VAC輸入)

$V_{AC}=220V$ , LED = 67V x 8pcs, 10W, 3階

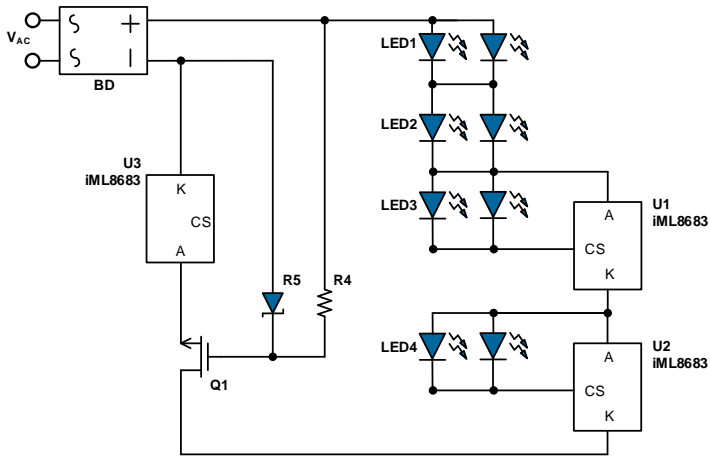

$V_{AC}$ (V)	$I_{IN}$ (mA)	PF	THD	$P_{IN}$ (W)
198	42.5	0.983	18.31	8.323
210	44.4	0.986	16.75	9.246
220	45.6	0.987	16.01	9.965
230	46.6	0.987	15.80	10.647
242	47.6	0.987	15.93	11.439
250	48.2	0.987	16.20	11.950
260	48.9	0.986	16.67	12.590

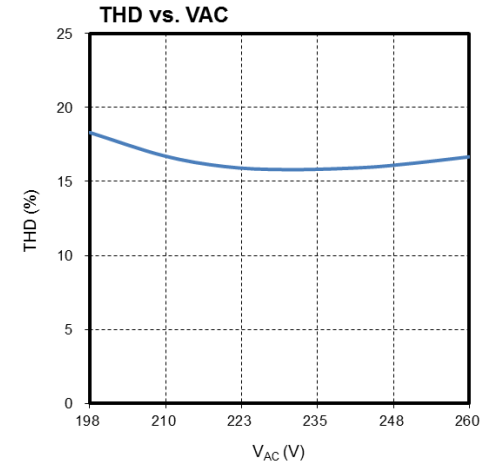
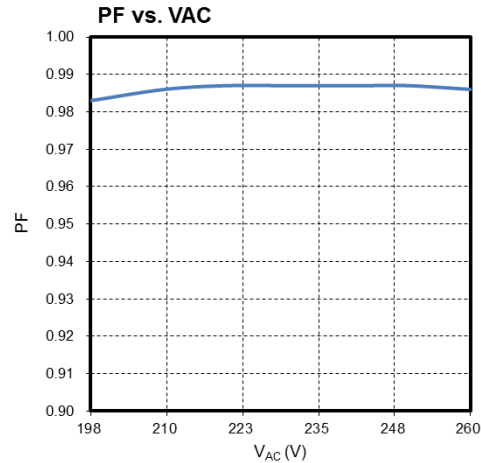
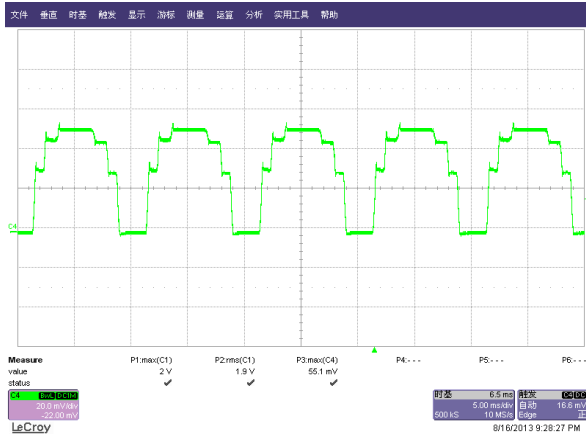



# iML8683 使用數量與驅動系統參數

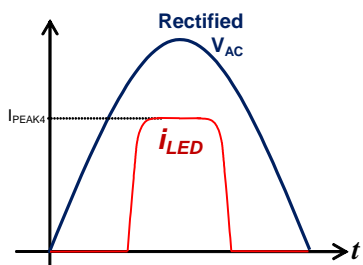
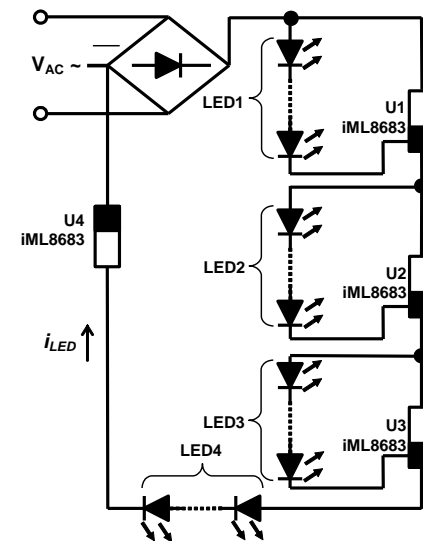
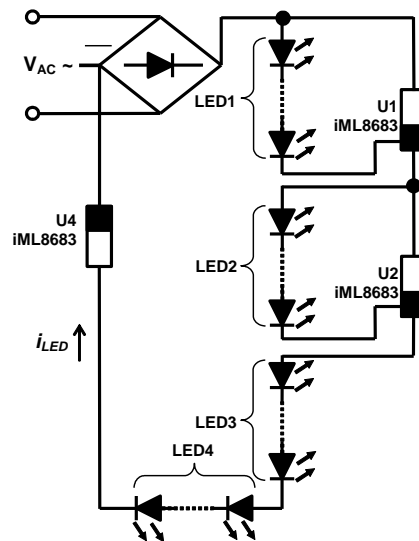
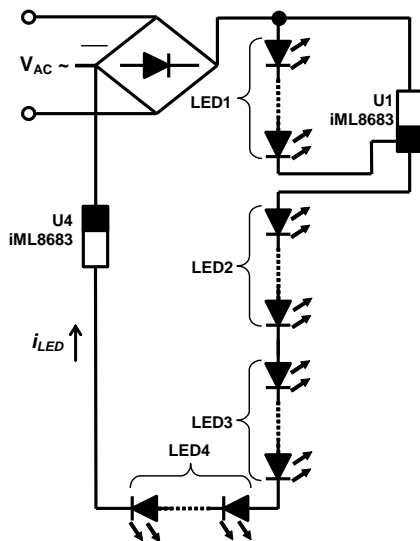
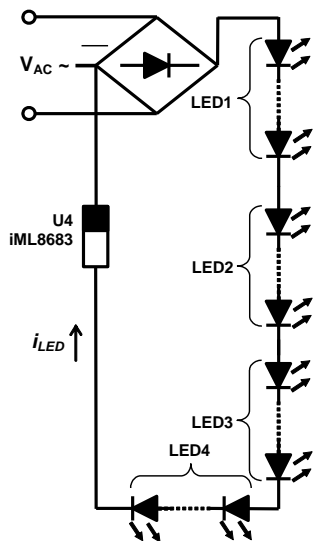

**1 Step**  
**PF=0.88**  
**THD=53%**  
**Power=7.1W**

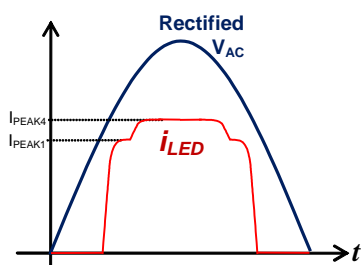

**2 Steps**  
**PF=0.96**  
**THD=29%**  
**Power=9.1W**

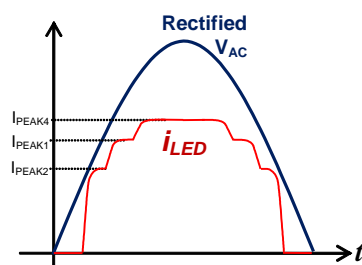

**3 Steps**  
**PF=0.98**  
**THD=16%**  
**Power=9.8W**

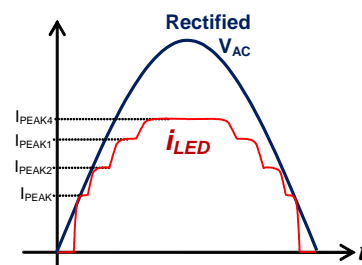

**4 Steps**  
**PF=0.99**  
**THD=10%**  
**Power=10W**





# iML8683 驅動系統EMI測試結果(未加 X電容)

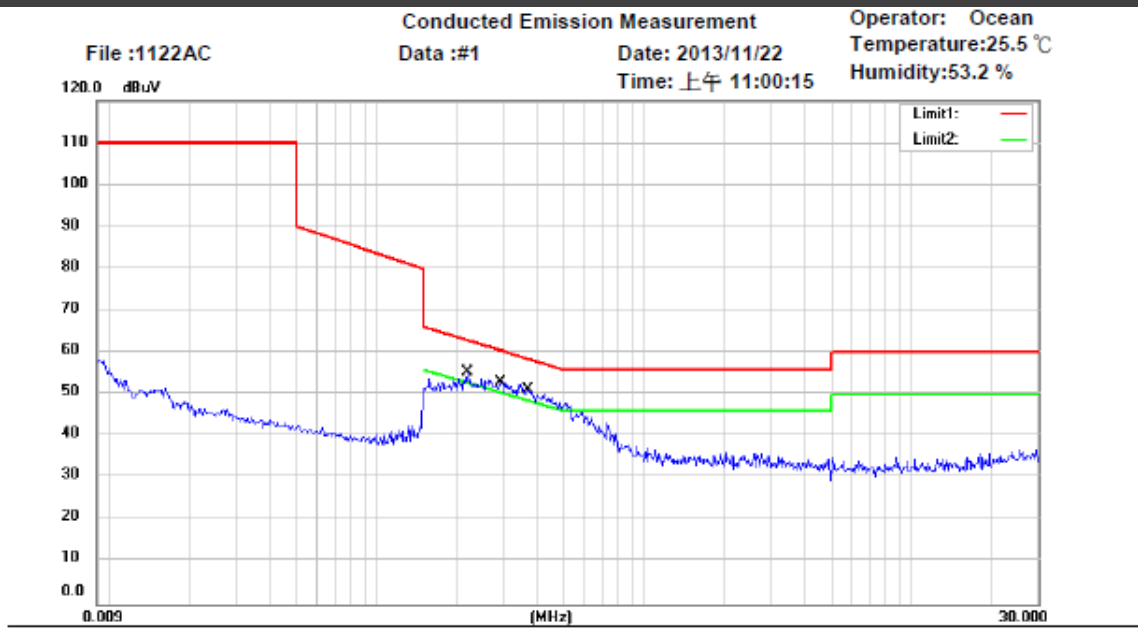

Site : Chamber\_03  
 Condition : EN55015 Conduction(QP)      Phase: N  
 EUT :      Power : 220VAC  
 M/N: i8683 10W Bulb  
 Test Mode :  
 Note :

Mk.	Frequency (MHz)	Reading (dBuV)	Detector	Corrected factor(dB)	Result (dBuV)	Limit (dBuV)	Margin (dB)	Comment
	0.2180	42.58	QP	10.10	52.68	62.89	-10.21	
	0.2180	29.57	AVG	10.10	39.67	52.89	-13.22	
*	0.2920	41.86	QP	10.11	51.97	60.47	-8.50	
	0.2920	28.23	AVG	10.11	38.34	50.47	-12.13	
	0.3754	39.61	QP	10.11	49.72	58.38	-8.66	
	0.3754	26.05	AVG	10.11	36.16	48.38	-12.22	



# iML8683 驅動系統之電流諧波 (IEC61000-3-2 Class D)

V(V)	220.9	I(A)	0.0403
P(W)	8.80	PF	0.986
F(Hz)	50.0	<b>THDi(%)</b>	<b>16.6</b>
I_Fund(A)	0.0398	V_Fund(V)	220.9
<b>Current Harmoic (A)</b>			
No.	Value	Limit	Pass/Fail
3	0.0022	0.0299	Pass
5	0.0035	0.0167	Pass
7	0.0029	0.0088	Pass
9	0.0025	0.0044	Pass
11	0.0002	0.0031	Pass
13	0.0007	0.0026	Pass
15	0.0006	0.0023	Pass
17	0.0019	0.002	Pass
19	0.0007	0.0018	Pass
<b>21</b>	<b>0.0014</b>	<b>0.0016</b>	<b>Pass</b>
23	0.0012	0.0015	Pass
25	0.0005	0.0014	Pass
<b>27</b>	<b>0.0001</b>	<b>0.0013</b>	<b>Pass</b>
<b>29</b>	<b>0.0009</b>	<b>0.0012</b>	<b>Pass</b>
31	0.0004	0.0011	Pass
33	0	0.001	Pass
35	0.0002	0.001	Pass
37	0.0001	0.0009	Pass
39	0.0007	0.0009	Pass



# iML8683 驅動系統之雷擊測試 (IEC61000-4-5)

## 220V 10 W System



Worldwide Testing Services(Taiwan) Co., Ltd.

### Surge

Applicant: Integrated Memory Logic, Inc.  
Standard: EN 61000 - 4 - 5  
Device: iML8683 10W LED  
Date: 2013.08.27

Temperature : 23.7 °C  
 Pressure : 990 hPa  
 Rel. humidity: 41 %

Model	Test mode	Voltage Angle	Waveform T <sub>r</sub> / T <sub>b</sub>	Repetition	Number of Tests/ Total	Performance criteria
#1 MOV471 R6=24V Zener NMOS=3N40	AC-line to line	+1000V 90°	1.2/50 μs	30s	5/5	A
		-1000V 270°	1.2/50 μs	30s	5/5	A

**Performance criteria:**

- A : No loss of performance or function
- B : Temporary loss of function or performance which is self recoverable
- C : Temporary loss of function or perform. which req. operate. intervention or system reset
- D : Loss of function which is not recoverable

## 120V/ 10W System



Worldwide Testing Services(Taiwan) Co., Ltd.

### Surge

Applicant: Integrated Memory Logic, Inc.  
Standard: EN 61000 - 4 - 5  
Device: iML8683 120V/ 10W LED Module  
Date: 2013.09.05

Temperature : 24.8 °C  
 Pressure : 990 hPa  
 Rel. humidity: 46 %

Model	Test mode	Voltage Angle	Waveform T <sub>r</sub> / T <sub>b</sub>	Repetition	Number of Tests/ Total	Performance criteria
#1 NMOS 1N60	120VAC-line to line	+500V 90°	1.2/50 μs	30s	5/5	A
		-500V 270°	1.2/50 μs	30s	5/5	A
		+750V 90°	1.2/50 μs	30s	5/5	A
		-750V 270°	1.2/50 μs	30s	5/5	A
#2 NMOS + MOV 1N60 221	120VAC-line to line	+750V 90°	1.2/50 μs	30s	5/5	A
		-750V 270°	1.2/50 μs	30s	5/5	A
		+1000V 90°	1.2/50 μs	30s	5/5	A
		-1000V 270°	1.2/50 μs	30s	5/5	A

**Performance criteria:**

- A : No loss of performance or function
- B : Temporary loss of function or performance which is self recoverable
- C : Temporary loss of function or perform. which req. operate. intervention or system reset
- D : Loss of function which is not recoverable

## 220VAC System

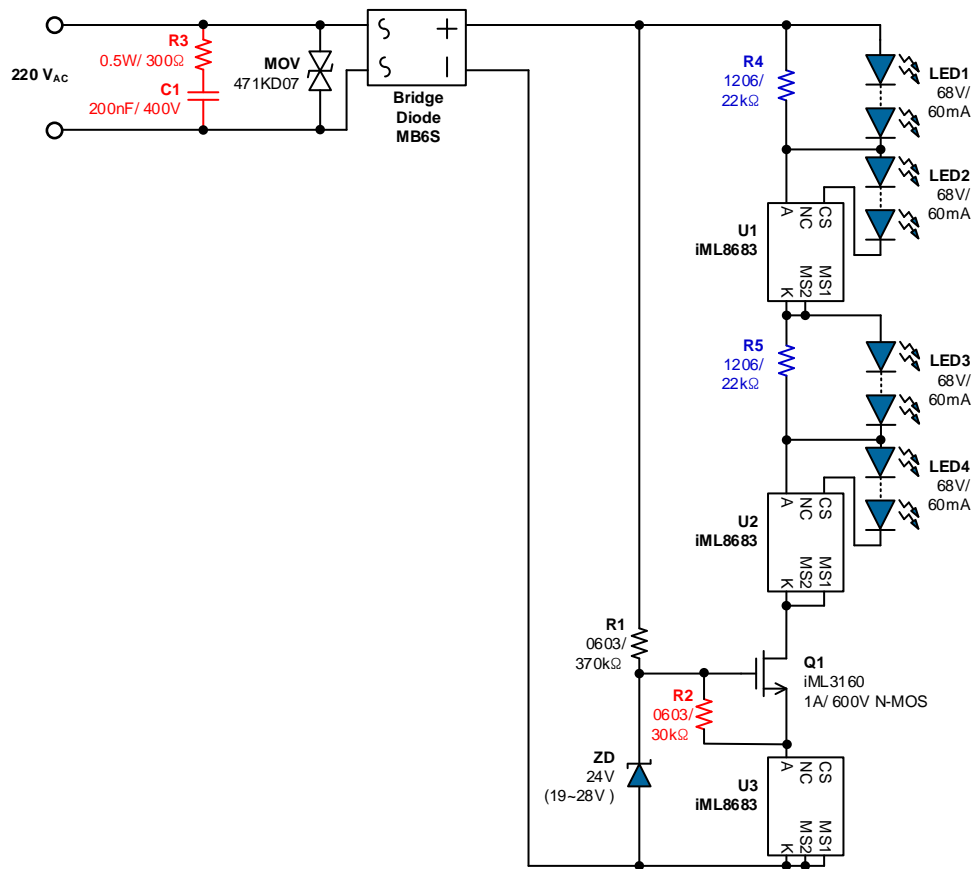

## 120VAC System

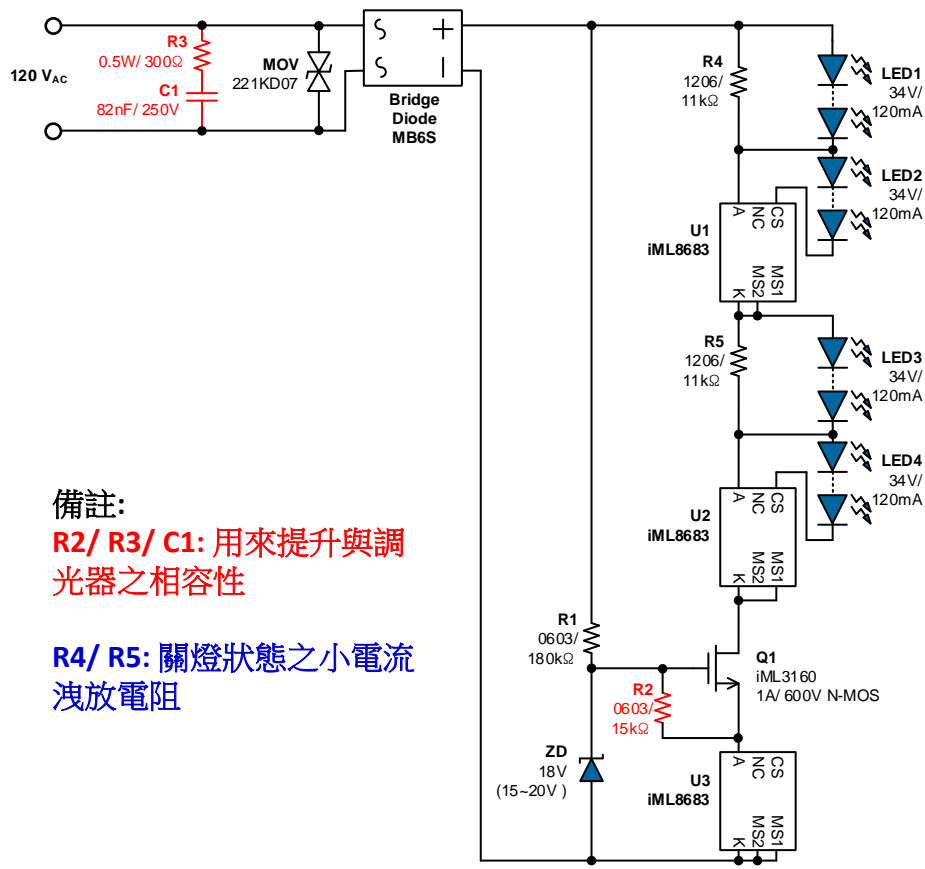

備註:

**R2/ R3/ C1:** 用來提升與調光器之相容性

**R4/ R5:** 關燈狀態之小電流洩放電阻



# TRIAC調光器相容性測試

## 110V/120V

Dimmer Specification						Dimming Performance	
Brands	Series	Model	Voltage	Power	Type	Compatibility (×: Unstable operation, Δ: Flickering slightly, ○: Compatible)	
Leviton	Trimatron	6684	120V	600W	Leading	without R/C	○
Leviton	Decora	6615	120V	300W	Trailing	without R/C	○
						R5=300Ω/ C1=82nF	○
Leviton	Sureslide	6615-P0W	120V	300W	Trailing	without R/C	○
						R5=300Ω/ C1=82nF	○
Leviton	Illumatech	IP106-1LZ	120V	600W	Leading	without R/C	○
						R5=300Ω/ C1=82nF	○
LUTRON	DIVA	DVCL-153P	120V	600W	Leading	without R/C	Δ
						R5=300Ω/ C1=82nF	○
LUTRON	DIVA	DV-600P-IV	120V	600W	Leading	without R/C	○
						R5=300Ω/ C1=82nF	○
LUTRON	DIVA	DVELV-300P	120V	300W	Trailing	without R/C	○
						R5=300Ω/ C1=82nF	○
LUTRON	Credenza	TT-300	120V	300W	Leading	without R/C	○
LUTRON	Ariadni	AY-600P-IV	120V	600W	Leading	without R/C	○
						R5=300Ω/ C1=82nF	○
LUTRON	Skylark	S-600P	120V	600W	Leading	without R/C	○
						R5=300Ω/ C1=82nF	○
LUTRON	Skylark	S-603PG	120V	600W	Leading	without R/C	Δ
						R5=300Ω/ C1=82nF	○
LUTRON	Nova	N-600-AL	120V	600W	Leading	without R/C	Δ
						R5=300Ω/ C1=82nF	○

## 220V/230V

Dimmer Specification					Dimming Performance	
Brand	Model	Voltage	Power	Type	Compatibility (×: Unstable operation, Δ: Flickering slightly, ○: Compatible)	
Busch-Jaeger	2250U	220V	600W	Leading	without R/C	×
					R5=300Ω/ C1=200nF	Δ
					R5=300Ω/ C1=300nF	○
Busch-Jaeger	2247U	220V	500W	Leading	without R/C	○
					R5=300Ω/ C1=200nF	○
					R5=300Ω/ C1=300nF	○
Busch-Jaeger	6519U	220V	550W	Trailing	without R/C	○
					R5=300Ω/ C1=200nF	○
					R5=300Ω/ C1=300nF	○
Busch-Jaeger	6513U	220V	420W	Trailing	without R/C	○
					R5=300Ω/ C1=200nF	○
					R5=300Ω/ C1=300nF	○
GIRA	0300-00	220V	400W	Leading	without R/C	×
					R5=300Ω/ C1=200nF	○
GIRA	0307-00/102	220V	400W	Trailing	without R/C	○
					R5=300Ω/ C1=200nF	○
NAM	ASW 3501	220V	500W	Leading	without R/C	×
					R5=300Ω/ C1=200nF	Δ
NAM	ASW 3701	220V	700W	Leading	without R/C	×
					R5=300Ω/ C1=200nF	Δ
NAM	ASW 3000	220V	1000W	Leading	without R/C	×
					R5=300Ω/ C1=200nF	Δ
					R5=300Ω/ C1=300nF	○

使用電解電容與部分LED並聯, 仍可維持PF值與THD同時可提升光效.

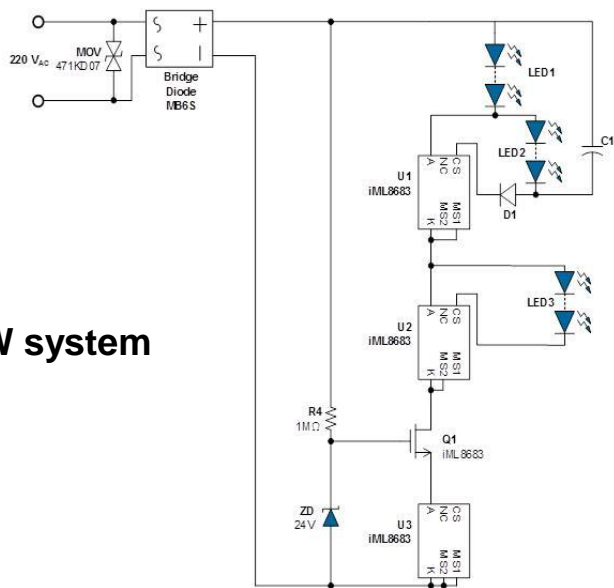

220V/ 10W system

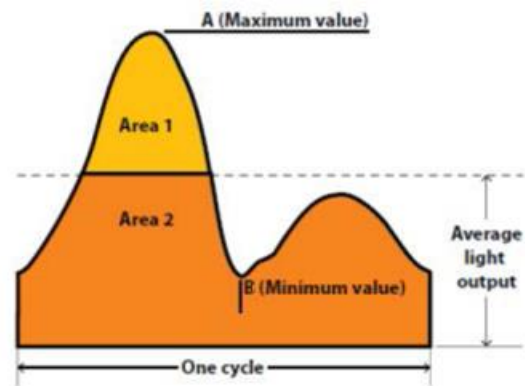

Source: IESNA Lighting Handbook, 10<sup>th</sup> Edition

- Percent Flicker =  $100\% \times \frac{A-B}{A+B}$
- Flicker Index =  $\frac{\text{Area 1}}{\text{Area 1} + \text{Area 2}}$

C1	VAC (V)	IAC (mA)	Power (W)	PF	THD (%)	Flux (lm)	Efficacy (lm/W)	Percent Flicker	Flicker Index
0 uF	221	46.3	10.09	0.9853	17.05	812	80.5	100%	0.32
1 uF	221	46.6	10.11	0.9819	18.69	829	82.0	92%	0.28
4.7 uF	221	46.5	10.07	0.9805	19.39	853	84.7	60%	0.17
10 uF	221	46.4	10.08	0.9803	19.59	855	84.8	40%	0.12
<b>20 uF</b>	<b>221</b>	<b>46.3</b>	<b>10.00</b>	<b>0.9801</b>	<b>19.70</b>	<b>862</b>	<b>86.2</b>	<b>31%</b>	<b>0.10</b>
30 uF	221	46.3	10.00	0.9801	19.70	870	87.0	28%	0.10



# 標準化EVM

提供客戶端標準化EVM作為客戶端設計參考

- (1). iML8683 規格書
- (2). iML8683 Application Note
- (3). 標準化EVM
- (4). 測試報告Test report
  - Power
  - Power Factor
  - THD
  - Current Harmonic IEC61000-3-2
  - EMI
  - ESD test IEC61000-4-2
  - EFT test IEC61000-4-4
  - Surge test IEC61000-4-5
  - BOM list
  - Layout Gerber file



Item	Application	Structure	VAC (V)	Power(W)			LED Qty	LED string structure	Flicker reduction
					Vf (V)	Color			
1	Bulb	Typical 3 steps	220	7~11	24	Warm White	28	6S3P+3S2P+2S2P	Yes
2	Bulb	Typical 3 steps	120	7~11	16	Warm White	28	4S4P+2S3P+2S3P	Yes
3	Downlight	Typical 3 steps	220	14	3	Warm White	88	24S1P+24S1P+20S1P+20S1P	Yes
4	Downlight	Typical 3 steps	120	14	3	Warm White	88	12S2P+12S2P+10S2P+10S2P	Yes
5	T5 tube	Balance 3 steps	220	8	16	Neutral White	18	4S1P+4S1P+4S1P+4S1P+1S2P	
6	T5 tube	Balance 3 steps	120	8	3	Neutral White	44	11S1P+11S1P+11S1P+11S1P	



# 220V/ 11W EVM光電參數

## 220V/ 11W 暖白色光引擎光電參數

Vin(V <sub>AC</sub> )	Iin (mA)	PF	THD	Pin(W)	Flux (lm)	Efficacy(lm/W)
220	47.84	0.985	17.46	10.416	878	84.3

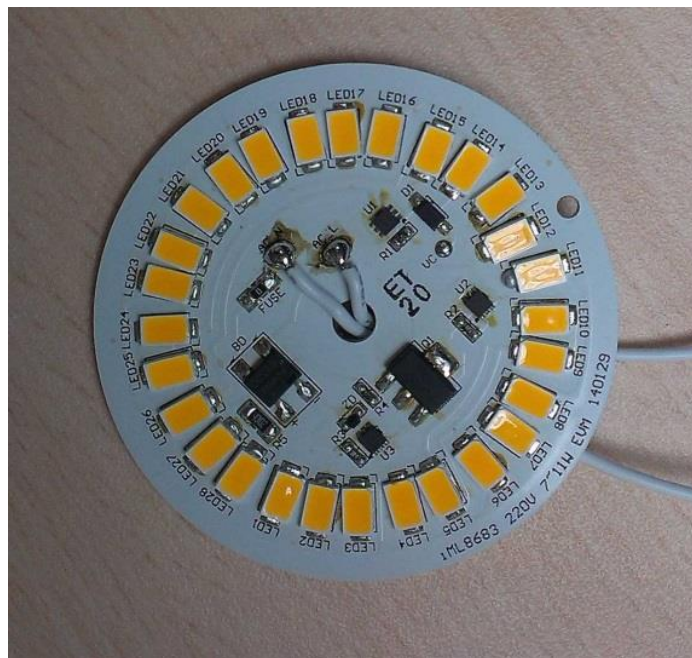





# 120V/ 11W EVM光電參數

## 120V/ 11W 暖白色光引擎光電參數

Vin(V <sub>AC</sub> )	Iin (mA)	PF	THD	Pin(W)	Flux (lm)	Efficacy(lm/W)
120	91.00	0.988	15.80	10.80	858	79.44

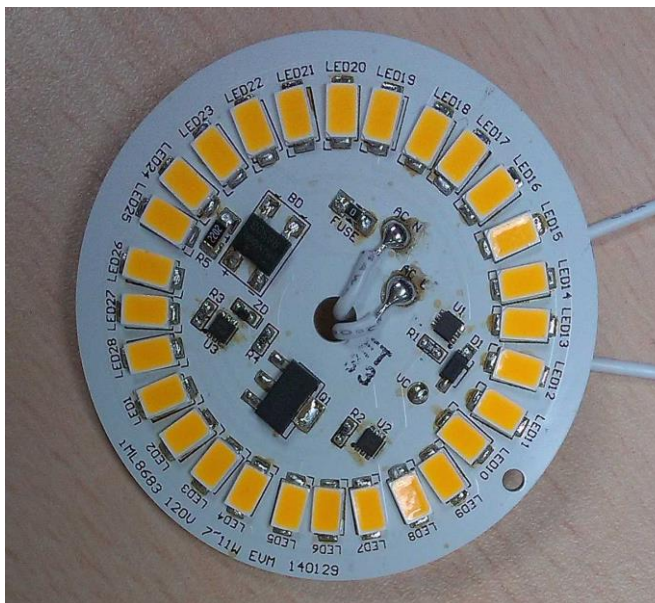



- iML公司簡介
- IML8683產品介紹
- 交流分段驅動產品發展規劃

## ✓ 高可靠度

- 減少元件數
- 無電解電容
- 元件耗熱低

## ✓ 低成本

- 簡化線路架構

## ✓ 小型化

- 易於組裝

## ✓ 可控制化- DALI, DMX512, IR, ZigBee, etc

- 可調光
- 可定址控制
- 可色溫控制

In one study it was found that 90% of the luminaire failures were due to something other than the LEDs!

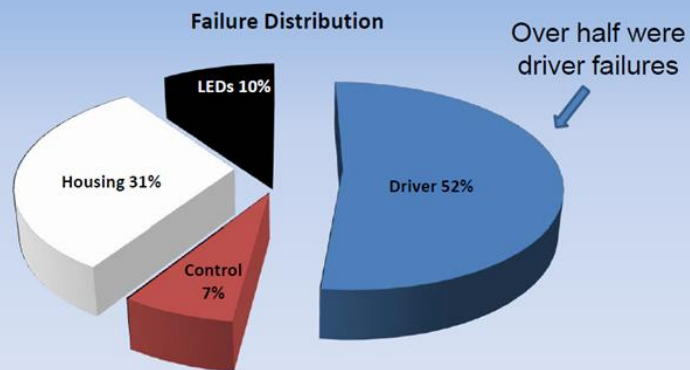

Total number of failures = 29 out of 5,400 units installed (0.54%)

Source: Appalachian Lighting Systems

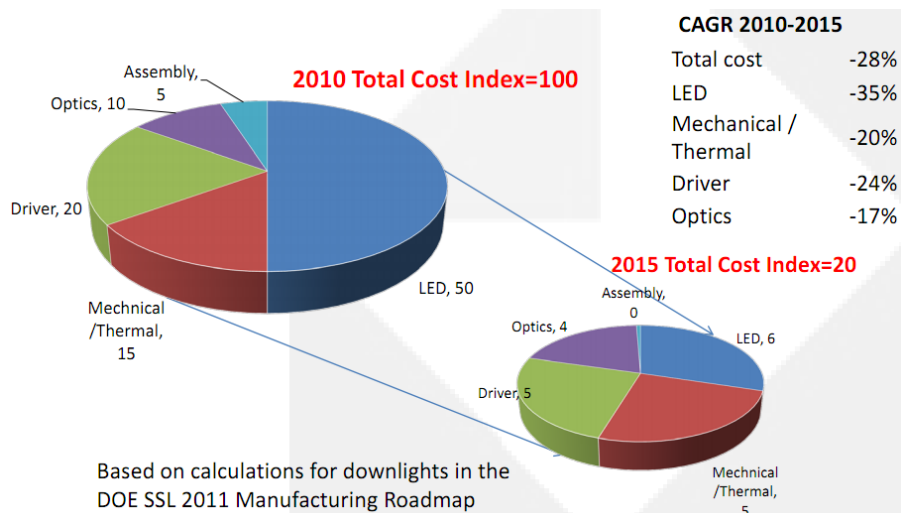



# 交流分段驅動產品發展規劃

產品定義中

產品開發中

現有產品

**iML8683**

80V/ Three Terminal  
Current Controller

External resistor setup current  
Build-in resistor option available  
TRIAC dimmable

**iML8681**

80V/ Two Terminal  
Current Controller

**iML8680**

60V/ Two Terminal  
Current Controller

2013

**iML8686**

80V/ TTCC/ Low Cost

<6W Low cost solution

**iML8685**

80V/ 400mA / TTCC

>20W Application  
E/S: Oct/14

**iML8671**

TTCC/ OVP/ Line Reg./  
0~10V/PWM Dimmable

0~10V & PWM Dimming,  
External MOSFET  
E/S: Jul/14

**iML8672**

TTCC/ Line Reg./  
OVP/ 600V MOSFET

Integrated 600V MOSFET  
E/S: Jun/14

**iML8670**

TTCC/ OVP/  
Line Reg.

Improved line regulation.  
External MOSFET  
E/S: Apr/14

2014

**iML86xx**

PLC Individual  
Controllable

Brightness Control,  
Color Temp. Control

**iML86xx**

Advanced AC  
Step Driver

Higher LED Usage Rate

**iML86xx**

Electronic Ballast  
Compatible AC step Driver

T8/T5 Fluorescent Lamp

**iML8684**

80V/ Two Terminal  
Current Controller

Higher Efficiency

**iML8690**

AC Step Driver

AC12V, MR-16

2015 ~



- ✓ 具智慧財產權保護
  - ✓ iML特有創新技術
  - ✓ 已獲得7項專利
  - ✓ 已開發3代產品
- ✓ 優勢
  - ✓ 低成本
  - ✓ 分散耗能, 可提高驅動功率
  - ✓ 具生產彈性之電路架構
  - ✓ 易於PCB布局
- ✓ 未來規劃: 將拓展至各式照明產品應用領域