



1.2A Single Channel LED Driver

Features

- 100mA~1.2A, single channel constant current regulator
- Output current adjustable by external resistor
- 3V ~ 12V wide range supply voltage
- 1MHz OE dimming support
- 400Hz V_{DD} dimming support
- 0V ~ 17V output sustain voltage
- low output voltage dropout
0.2V dropout at 150mA output
0.6V dropout at 1.2A output
- Minimized I_{DD} consumption
- 160°C half power thermal protect
- Less than ±4% chip current skew
- Less than 0.5%/V line regulation
- Less than 1%/V load regulation
- Green package

Applications

- General LED Lighting
- Decoration lighting for architecture
- LCD back lighting
- Street lamp

Package Type

- TO252-5L

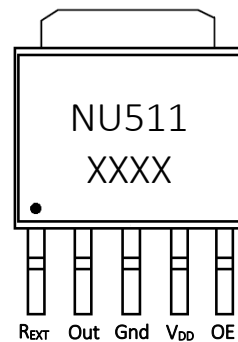

Product Description

The NU511 is a single channel, open drain, linear constant current LED driver. With up to 1.2A driving current and maximum 1Mhz PWM dimming control support, NU511 can be used for 0.5W to 3W high power LED string in general or architecture decoration lighting applications.

The wide power supply range capability makes NU511 work stably in uncertain power supply applications. When the power supply voltage is changed or fluctuating, the output current still remains unchanged. With this dedicate designed function, the V_{DD} power can be derived easily from the whole lighting system.

The output current of NU511 is set by an external resistor. While in full current output, the NU511 only need about 0.6V drop on output channel. The minimized voltage drop will increase the working range that limited by LED forward voltage variation in lighting system, to enhance the system efficiency and lower the heat generation from NU511.

Terminal Description

Pin #	Pin name	Function
1	REXT	R external
2	OUT	Output
3	Gnd	Ground
4	V _{DD}	Power
5	OE	Output enable

Protection Circuit

- 8KV output channel ESD protection

Maximum Ratings (T = 25°C)

Characteristic	Symbol	Rating	Unit
Supply voltage	V _{DD}	3.0 ~ 16	V
Output voltage	V _{OUT}	-0.2 ~ 20	V
Input voltage	V _{OE}	-0.2 ~ V _{DD}	V
Output current	I _{OUT}	1.4	A
Ground terminal current	I _{GND}	1.4	A
Power Dissipation (On PCB)	P _D	3.2	W
Thermal Resistance	R _{TH(j-a)}	42	°C/W
Operating temperature	T _{OPR}	-40 ~ +130	°C
Storage temperature	T _{STG}	-55 ~ +150	°C

Electrical Characteristics and Recommended Operating Conditions

Characteristic	Symbol	Condition	Min.	Typ.	Max.	Unit
Supply voltage	V _{DD}	Room Temp.	3	-	12	V
Output sustain voltage	V _{omax}	I _{OUT} = 0A	-	-	17	V
Output current	I _{OUT}	-	100	-	1200	mA
Output drop out voltage	V _{OUT}	V _{DD} = 5V, I _{OUT} = 150mA	0.2	-	-	V
		V _{DD} = 5V, I _{OUT} = 350mA	0.3	-	-	V
		V _{DD} = 5V, I _{OUT} = 1200mA	0.6	-	-	V
Power dissipation	P _D	Room Temp.	-	-	1.8	W
Chip to chip current skew V _{DD} >= 3V	dI _{OUT2}	I _{OUTn} = 1200mA	-	±2	±3.5	%
Leakage	I _{Leakage}	V _{OUT} = 7V	-	-	1	uA
OE Input voltage	V _{IH}	V _{DD} < 5V	-	0.7*V _{DD}	-	V
		V _{DD} >= 5V	-	-	3.5	
	V _{IL}	V _{DD} < 5V	-	0.3*V _{DD}	-	
		V _{DD} >= 5V	-	-	1.5	
Pull down resistor (OE)	R _{PD}	On small area PCB	400	500	700	KΩ
Line regulation	%/V _{DD}	3V < V _{DD} < 12V	-	-	0.5	△%/V
Load regulation	%/V _{OUT}	0.5V < V _{OUT} < 8V	-	-	1	△%/V
Operating Temperature	T _{OPR}	Ambient temperature	-40	-	85	°C
Thermal protect (Junction temperature)	T _{HalfP}	Half current output	-	160	-	°C
Thermal regulation	%/10°C	-	-	-	0.5	△%/10°C
Supply current	I _{DD}	R _{EXT} = Open, Output off	-	0.3	1	mA
		I _{OUT} = 365mA, Output on	2	4	4.5	mA
		I _{OUT} = 700mA, Output on	-	4.7	-	mA
		I _{OUT} = 1000mA, Output on	-	5.0	-	mA

System voltage	V _{LED}	V _{DD} < 12V	5	-	24	V
----------------	------------------	-----------------------	---	---	----	---

Switching Characteristics (T = 25°C)

Characteristic	Symbol	Condition	Min.	Typ.	Max.	Unit
Propagation Delay Time (OE from "L" to "H")	t _{pLH}	V _{DD} =4V, V _{OUT} =1V, I _{OUT} =120mA, OE= 0V → 4V	200	280	360	nS
Output current rising time (OE from "L" to "H")	t _{oERise}	V _{DD} =4V, V _{OUT} =1V, I _{OUT} =120mA, OE= 0V → 4V	30	50	80	nS
Propagation Delay Time (OE from "H" to "L")	t _{pHL}	V _{DD} =4V, V _{OUT} =1V, I _{OUT} =120mA, OE= 4V → 0V	560	620	680	nS
Output current falling time (OE from "H" to "L")	t _{oEfall}	V _{DD} =4V, V _{OUT} =1V, I _{OUT} =120mA, OE= 4V → 0V	60	90	130	nS
Propagation Delay Time (V _{DD} from "L" to "H")	t _{pON}	V _{OUT} =1V, I _{OUT} =120mA, V _{DD} =OE= 0V → 3V	-	30	-	uS
Output current rising time (V _{DD} from "L" to "H")	t _{vDDRise}	V _{OUT} =1V, I _{OUT} =120mA, V _{DD} =OE= 0V → 3V	-	5	-	uS
Propagation Delay Time (V _{DD} from "H" to "L")	t _{pOFF}	V _{OUT} =1V, I _{OUT} =120mA, V _{DD} =OE= 3V → 0V	-	3	-	uS
Output current falling time (V _{DD} from "H" to "L")	t _{vDDFall}	V _{OUT} =1V, I _{OUT} =120mA, V _{DD} =OE= 3V → 0V	-	5	-	uS

Timing Waveform

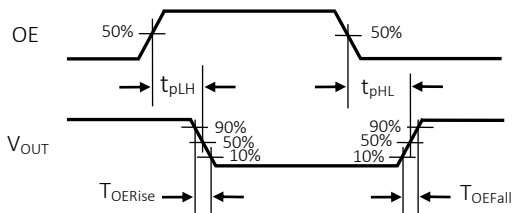

OE timing diagram

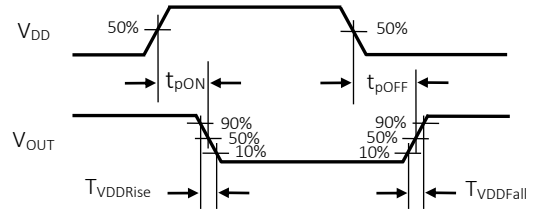

V_{DD} timing diagram (V_{DD}=V_{OE})

Test Circuit

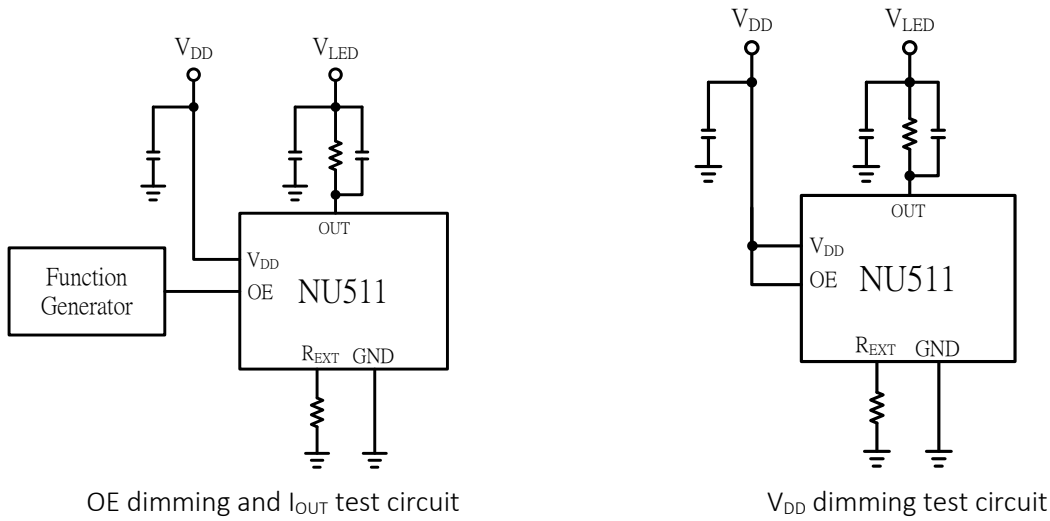

Block Diagram

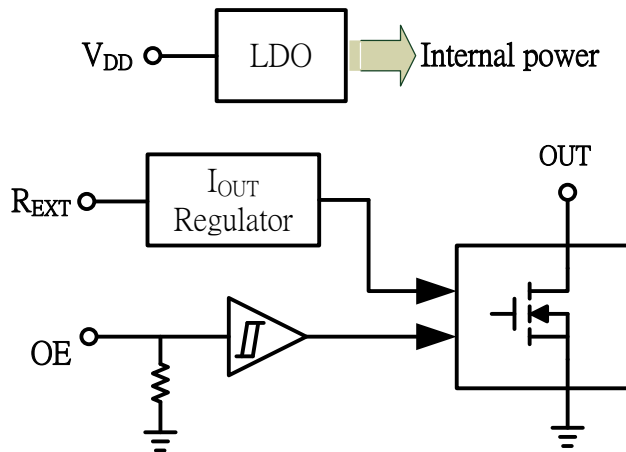

Equivalent Circuits for Inputs

There is only one OE input terminal to which a pull down resistor is connected. While OE is high voltage, the output channel is turned on.

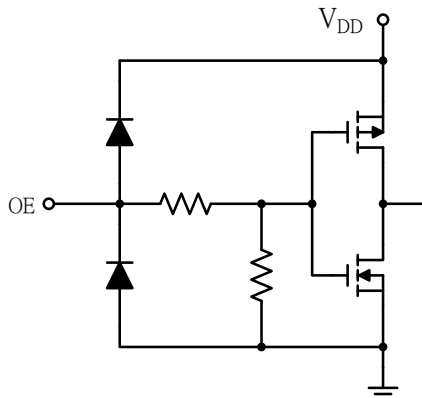

Output Current Setting

The output current of each channel of NU511 is set by an external resistor (R_{EXT}). The relationship between output current and external resistor is shown in the figure or calculated from the equation following.

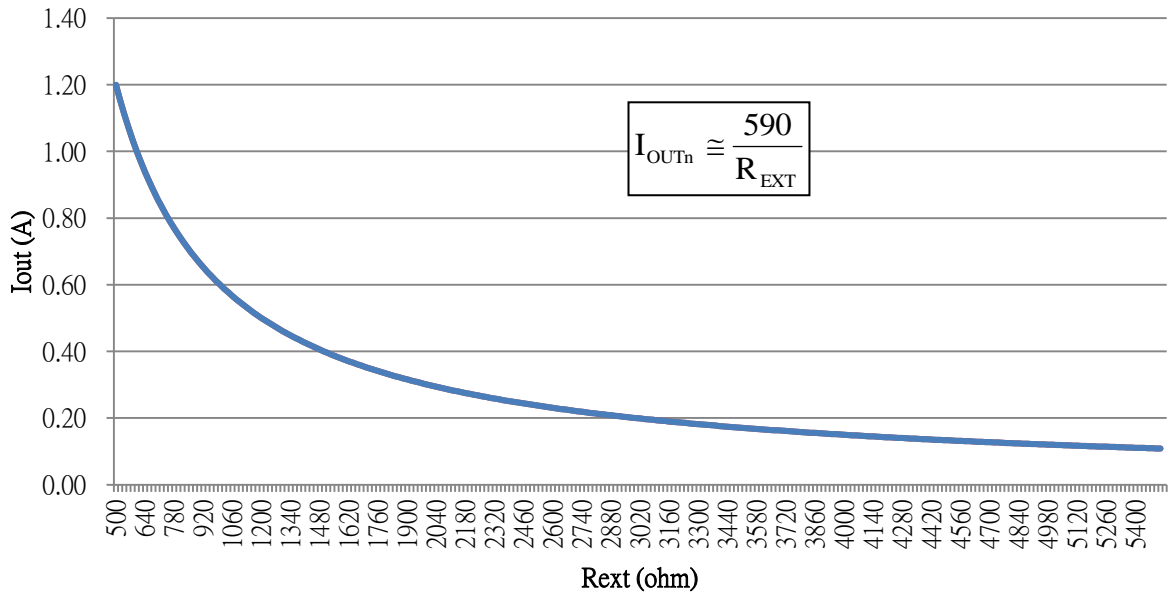

I/V Curve

I_{OUT} vs. V_{OUT} curve (Single channel)

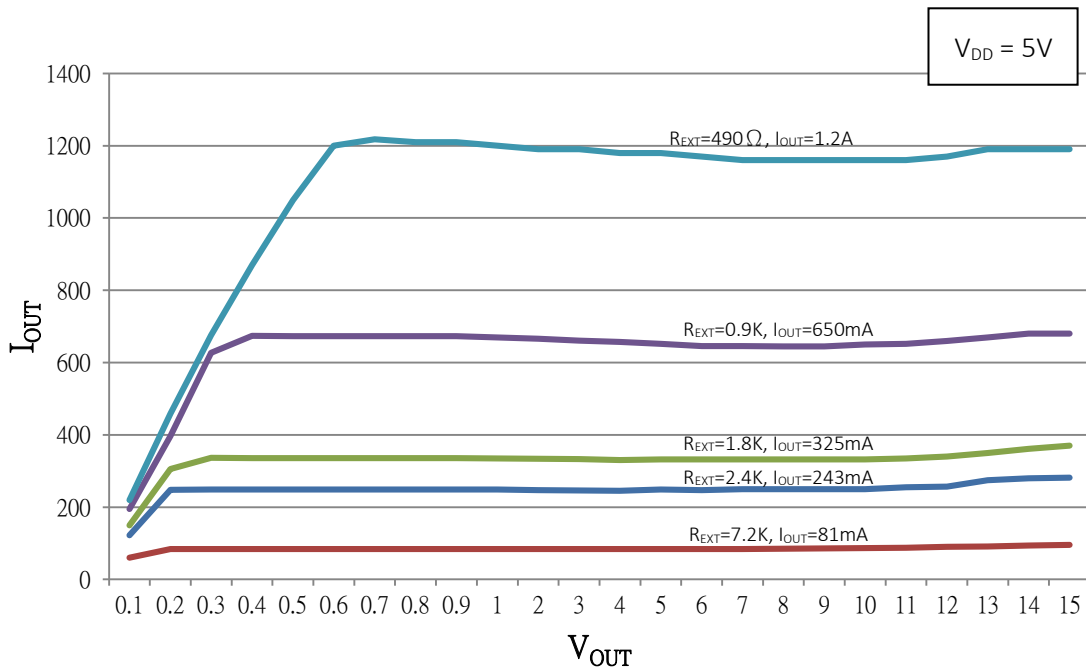

Typical Application Circuit

● Dimming application

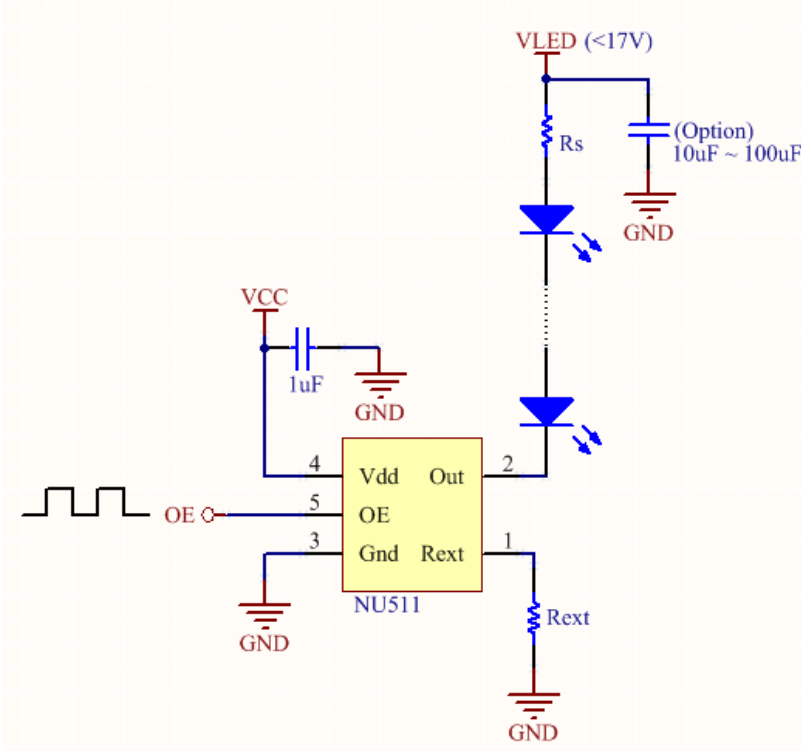

● General lighting application 1

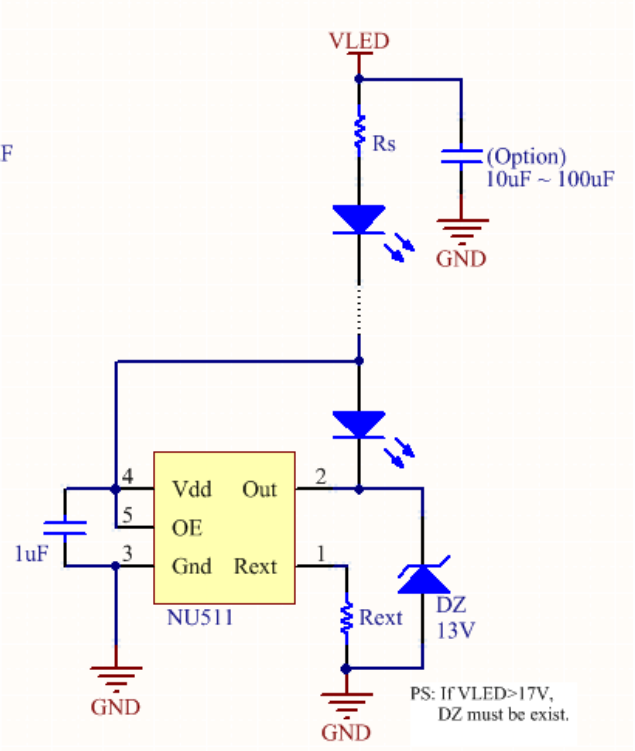

● General lighting application 2

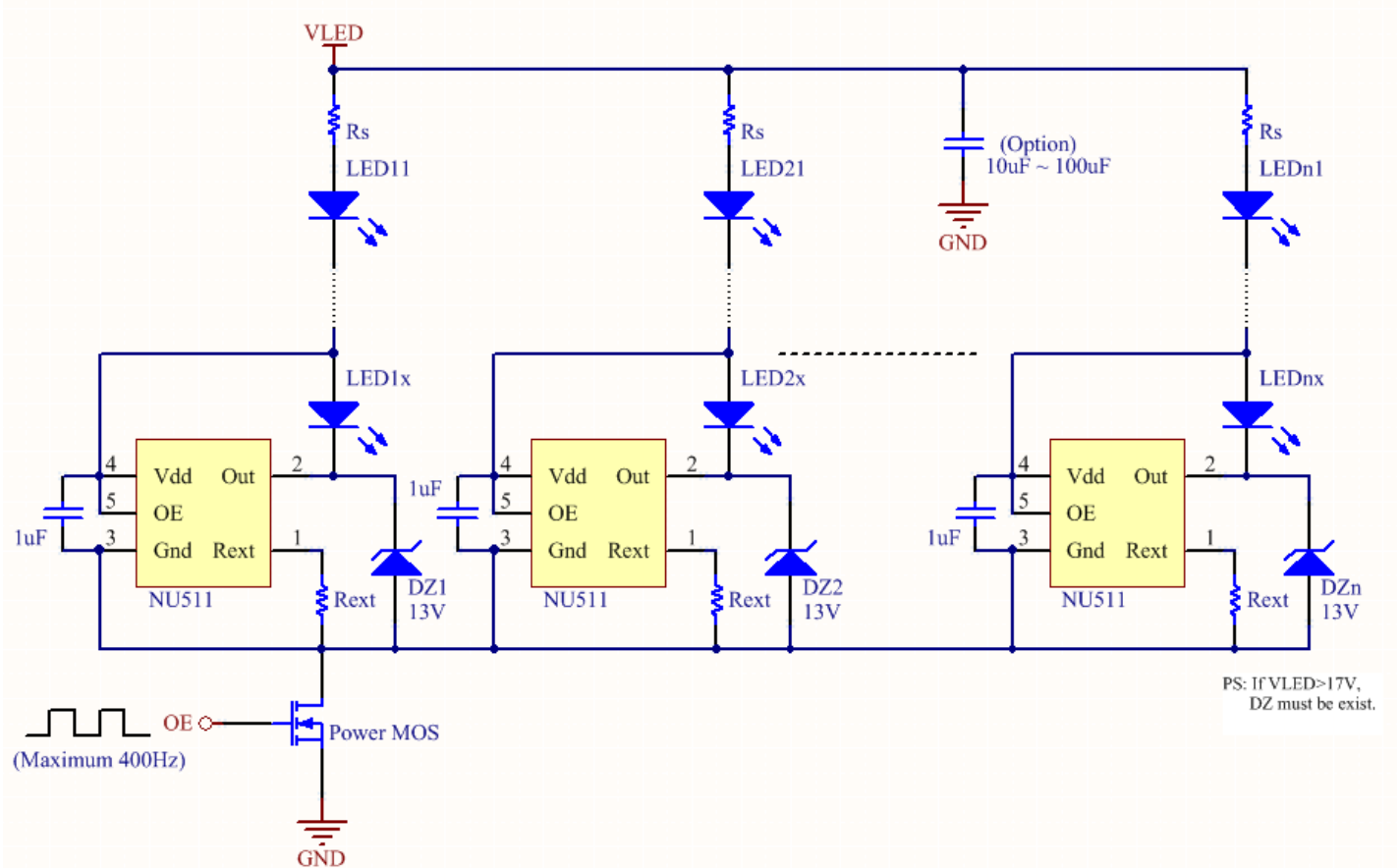

Note:

1. For the heat consideration on driver, V_{OUT} of NU511 should be minimized. The power calculation equation is shown as bellow.

$$V_{OUT} = V_{LED} - V_F * n$$

$$P_D = V_{OUT} * I_{OUT}$$

Where V_{OUT} is the voltage on output pins, I_{OUT} is output current of NU511, V_F is voltage drop of LED and n is the number of LEDs. In some higher V_{OUT} applications, to series a proper resistor in output current path can decrease the V_{OUT} and get less heat generation from NU511.

2. For the efficiency consideration, higher V_{LED} voltage and more LEDs in current path will get higher electrical efficiency. With the wide range supply voltage design and self powering structure like the lighting application circuit on previous page, NU511 can be used in maximum 24V (V_{LED}) power system.
3. More LED in series, the total voltage drop variation on LEDs will increase. This variation is derived from the different V_F bins of LEDs and LED temperature rising while system is working. That probably increases P_D . So, it is another trade off to select the proper V_{LED} voltage and the number of LEDs in system. The more output current is driving, the less LED in series is better.

Power Dissipation and Recommend Iout-Vout Table

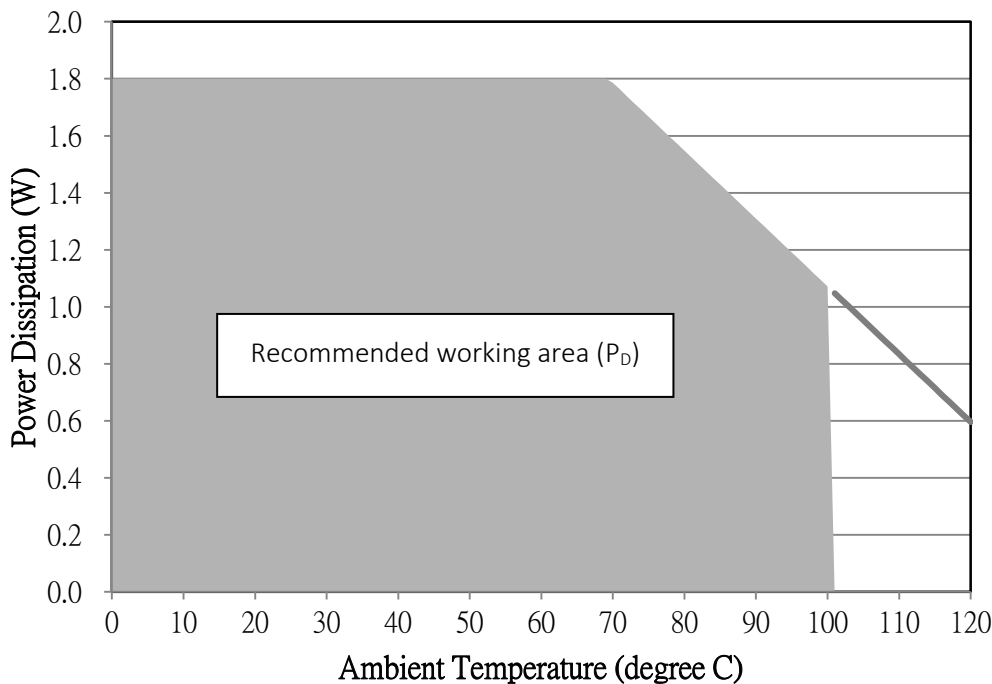

Iout (A)	Max. Vout (V) recommended
0.1	17
0.2	9
0.3	6
0.4	4.5
0.5	3.6
0.6	3
0.7	2.57
0.8	2.25
0.9	2
1	1.8
1.1	1.64
1.2	1.5

Package Dimensions

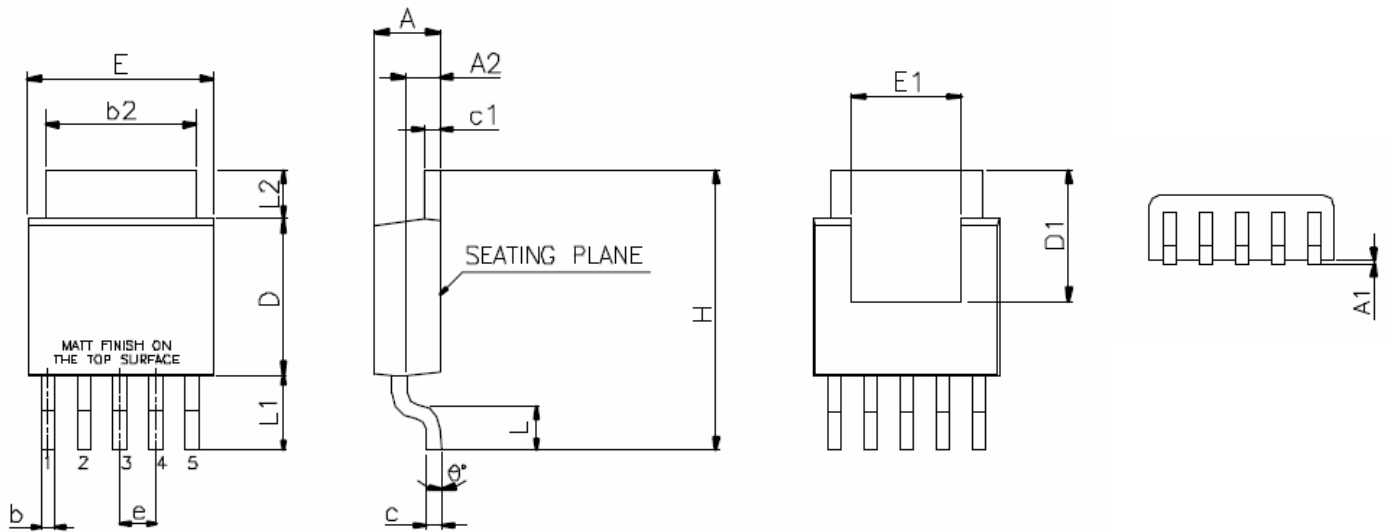

SYMBOLS	DIMENSIONS IN INCH		DIMENSIONS IN MILLIMETER	
	MIN.	MAX.	MIN.	MAX.
A	0.086	0.094	2.18	2.39
A1	0.000	0.005	0.00	0.13
A2	0.040	0.050	1.02	1.27
b	0.020 TYP.		0.51 TYP.	
b2	0.205	0.215	5.21	5.46
c	0.018	0.023	0.46	0.58
c1	0.018	0.023	0.46	0.58
D	0.210	0.220	5.33	5.59
D1	0.180	—	4.57	—
E	0.250	0.265	6.35	6.73
E1	0.150	—	3.81	—
e	0.050 BSC.		1.27 BSC.	
H	0.370	0.410	9.40	10.41
L	0.055	0.070	1.40	1.78
L1	0.105 REF.		2.67 REF.	
L2	0.06	0.08	1.52	2.03
θ	0°	4°	0°	4°

NOTES:

1. JEDEC OUTLINE : N/A

Taping Specification

PACKAGE	Q'TY/REEL
TO252-5	3,000 ea

Restrictions on product use

- NUMEN Tech. reserves the right to update these specifications in the future.
- The information contained herein is subject to change without notice.
- NUMEN Technology will continually working to improve the quality and reliability of its products. Nevertheless, semiconductor device in general can malfunction or fail due to their inherent electrical sensitivity and vulnerability to physical stress. It is the responsibility of the buyer, when utilizing NUMEN products, to comply with the standards of safety in making a safe design for the entire system, and to avoid situations in which a malfunction or failure of such NUMEN products could cause loss of human life, bodily injury or damage to property. In developing your designs, please ensure that NUMEN products are used within specified operating ranges as set forth in the most recent NUMEN products specifications.
- The NUMEN products listed in this document are intended for usage in general electronics applications (lighting system, personal equipment, office equipment, measuring equipment, industrial robotics, domestic appliances, etc.). These NUMEN products are neither intended nor warranted for usage in equipment that requires extraordinarily high quality and/or reliability or a malfunction or failure of which may cause loss of human life or bodily injury (“Unintended Usage”). Unintended Usage include atomic energy control instruments, airplane or spaceship instruments, transportation instruments, traffic signal instruments, combustion control instruments, medical instruments, all types of safety devices, etc.. Unintended Usage of NUMEN products listed in this document shall be made at the customer’s own risk.