

NEM



NE1118 12V/5A
COC V5.0 Tier2 &DOE V6.0
Design

NE1118低待機功耗的內建全功能節能控制器

NE1118為帶高壓啟動S0-8腳封裝的全功能低待機功耗電源管理晶片，為了提高電源產品的性能，晶片內部構建了電源需要的絕大部份重要特徵；NE1118自動的降頻至26K，實現高能效的要求；

Features

- 輸入過/欠壓保護的高壓啟動功能
- 內建精確的高低壓過功率補償功能
- 內建斜坡補償功能
- 內建動態負載下的補充供電功能
- 內建X cap 放電功能
- 待機的峰值電流限制減小異聲
- 輕載條件下，頻率降低至 26KHz
- 開環狀態下的可恢復保護功能
- 輸出短路可恢復保護功能
- 內建4mS的軟啟動
- 內建240nS的前沿消隱時間
- +500mA/-800mA驅動能力
- 頻率抖動
- 逐週期的最大電流限制保護

Advantages

- ✓ 精確的高低壓過功率補償
- ✓ 內建全功能的電源特徵
- ✓ 靈活的保護特徵
 - 開環保護
 - 過壓保護
 - 滿足DOE能效6要求
- ✓ Vcs滿足LPS要求

Ordering Information

Part	OPP delay	BO delay	Pin1 High/Low	OLP	Marking
NE1118C	20mS	20mS	Auto-recovery	Auto-recovery	NE1118C
NE1118D	100mS	60ms	Latch	Auto-recovery	NE1118D

NE1118 典型特徵

	NE1118C	Remark
HV-Pin	650V	具有更高的耐壓值；
Bi/Bo	85Vac/75Vac	具有精確的BI/BO功能（可選）；
BO Delay	20mS, 100mS	具有更快的關閉速度, 更快速保護系統(可選)；
AC Line OVP	Yes(300Vac),No	具有輸入線電壓過壓保護（可選）；
X-cap discharge	Yes	具有X電容放電功能；
OPP Compensation	HV Compensation	採用先進的內部補償（不同於傳統補償方式）； 輸入高低壓的過流保護點一致性更高；
VCC(on)	12V	具有更低的啟動電壓；
VCC-OVP	30V	具有更高的過壓保護點及更寬的供電範圍；
Gate Clamping Voltage	13.5V	驅動鉗位，保護MOS；
Slope Compensation	Vfb Compensation	採用先進的內部補償方式（不同於傳統補償方式）； 芯片內部自動調節，無需外部設置；
OPP Delay	20mS	延遲時間更短，更快速保護系統；

NE1118 Typical Application

Typical Application

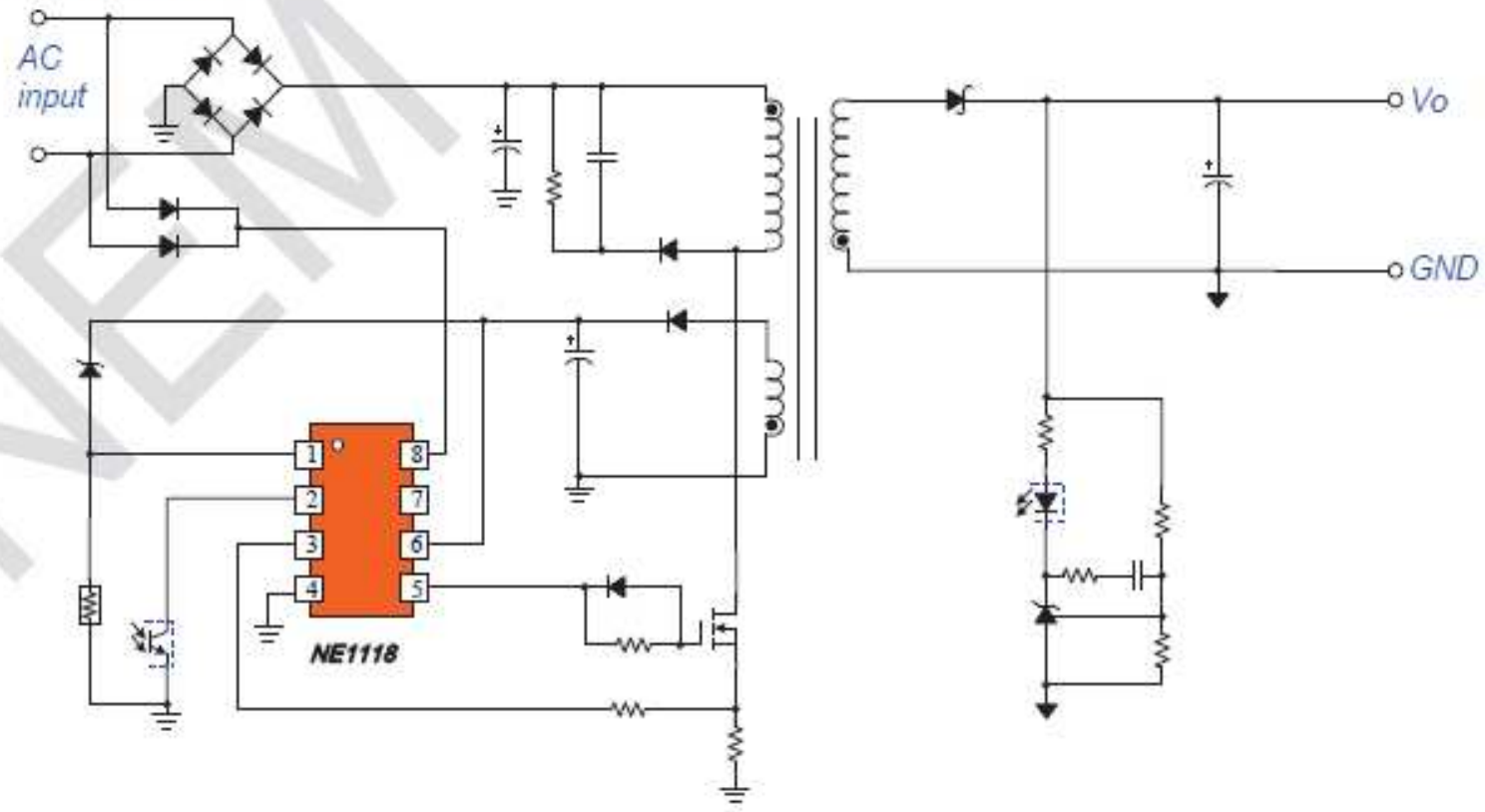

引腳分配及封裝

Pin Assignment

Pin Name	Pin no.	Function Description
Pro	1	保護腳, 電壓低於1V或高壓3V保護; 如果不使用, 懸空或100K電阻連接到地;
FB	2	電壓回饋腳, 連接一個光耦控制輸出電壓
CS	3	電流檢測
GND	4	地
GATE	5	驅動腳
VCC	6	供電腳
NC	7	懸空腳
HV	8	帶X Cap 放電功能的高壓啟動腳

Package : SOT-26

NE1118= Device
 Y=YEAR
 M=Month
 D=Date
 X=Assembly Info.
 N=Serial No.

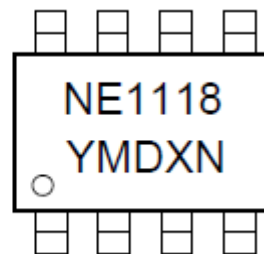

PSU Specifications

Input Characteristics

Rated Input Voltage: 90~264Vac

■ Frequency Range: 47~63Hz:

■ Efficiency: Eff.> 89% @230Vac/50Hz ; Eff.>88%@115Vac/60HZ

■ BI/Bo:85Vac/75Vac;BO Delay time:<30mS

■ X-Discharge:<1Sec

Output Characteristics

Operating Voltage : 12V

■ Normal Current: 5A

■ Rated Power: 60W

■ Minimum Output Voltage: 11.75V@ Io=5A, Vin=264Vac/47Hz

■ Dynamic loading Response:Vout+/-0.6V

■ Output over/under shoot:<5%Vout

■ Turn On Delay/Turn off Delay/DC Rise/Fall Time:

Turn on time(<1Sec)@115VAac

Turn off time(<30mS)@115Vac/230Vac

Rise/fall time(<40mS)

■ Over Current Protection: 6.0-6.5A;

■ Over Current Protection delay time<20mS

CoC V5.0 tier 2 and DOE V6

COC V5.0 tier 2 : Standby <150mW, Eff>89%;

DOE V6.0:Standby<100mW, Eff>88%;

12V5A Demo Board Picture



12V5A Demo Board PCB Layout

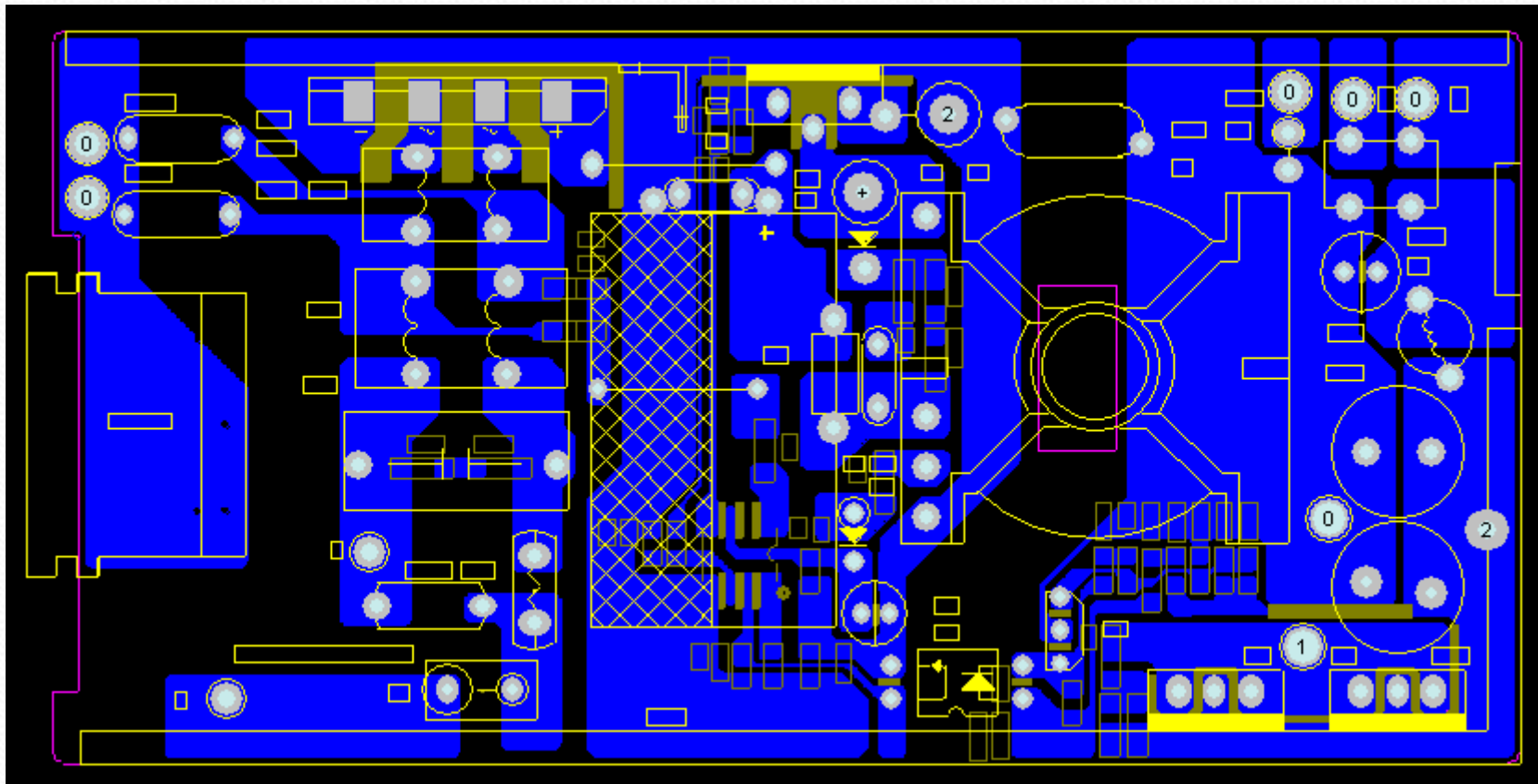

12V5A Demo Board Schematic

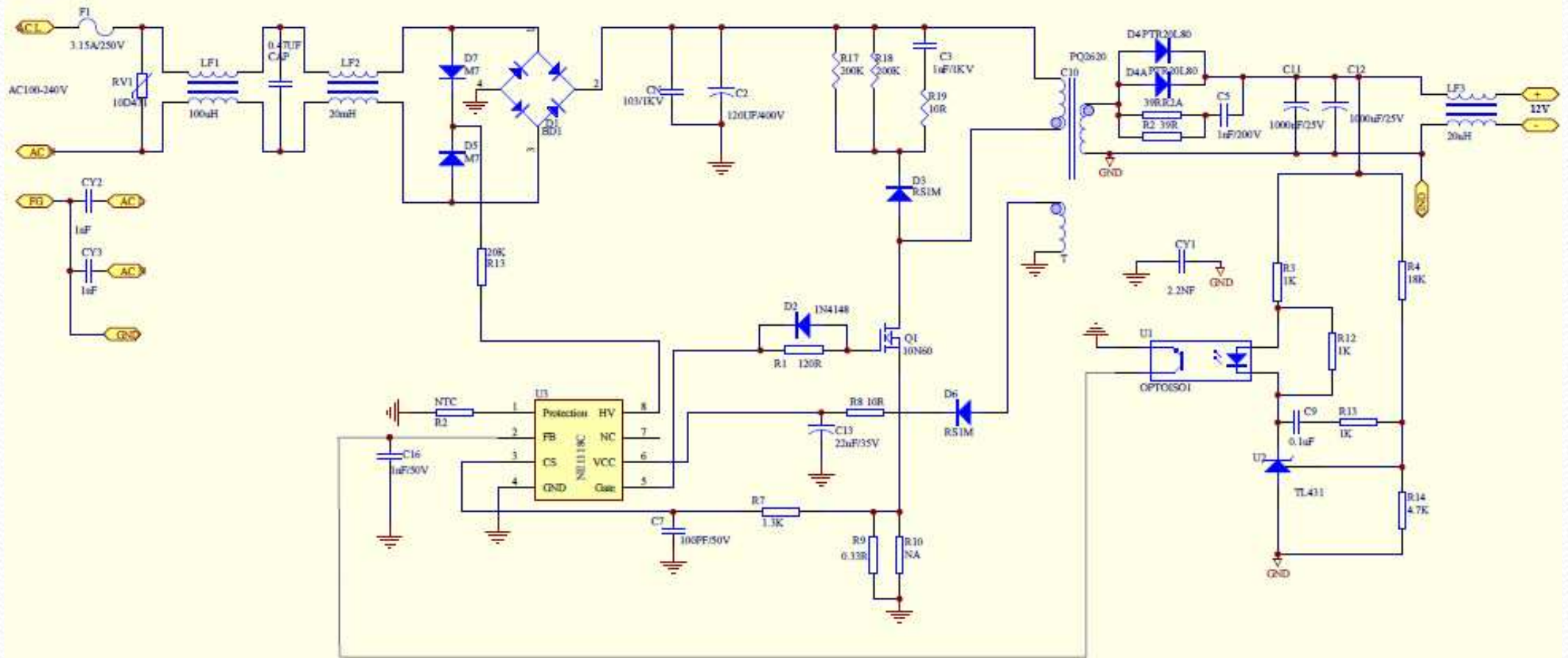

主要元件：

变压器:PQ2620；

MOS管：K10N60；

肖特基：SBR20U100/PTR20V100；

芯片:NE1118

12V5A Demo Board Performance

Efficiency:

Output voltage is measured at the end of 16# 1.5m Wire (Burn-in 10 Minutes);

	Vin(ac)	Pin(W)	Vout(V)	Iout(A)	Pout(W)	Eff(%)	Avg Eff(%)
NE1118	115Vac/60Hz	67.90	11.91	5.004	59.6	87.77	89.15%
		51.07	11.99	3.76	45.08	88.27	
		33.65	12.07	2.501	30.18	89.68	
		16.78	12.154	1.256	15.26	90.89	
	230Vac/50Hz	67.29	11.909	5.004	59.59	88.55	89.67%
		50.14	11.991	3.746	44.92	89.58	
		33.53	12.072	2.501	30.19	90.03	
		16.85	12.153	1.256	15.26	90.52	

No load consumption

Vin (Vac)	Fin (Hz)	Standby Power
115	60	34mW
230	50	48mW

12V5A Demo Board Performance

X-cap Discharge Measurement:

Vin(Vac)	Freq(Hz)	Loading(A)	Spec Max.(mS)	Reading(ms)
90	60	5.00	1000.00	45.56
115	60	5.00	1000.00	49.37
230	50	5.00	1000.00	203.24
264	50	5.00	1000.00	345.29

12V5A Demo Board Performance

Brown In/Brown out Voltage and Brown out Delay time:

Brown In	74.6Vac		Voltage	Delay time
Brown out	64.7Vac	Brown out	64.7Vac	20.2mS

Over Current Protection Measurement:

	Vin (Vac)	Fin (Hz)	OCP
NE1118	90Vac	60	6.34A (126%)
	115Vac	60	6.42A (128%)
	230Vac	50	6.40 (128%)
	264Vac	50	6.43 (128%)

Over Current Delay time:

Vin (Vac)	Fin (Hz)	Delay time
115	60	16.67mS
230	50	16.85mS

12V5A Transformer Design

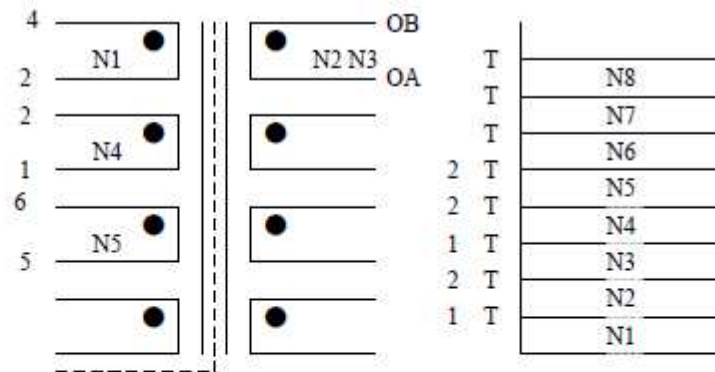

NO	WIRE MATERIAL (mm)	TURNS	LAYERS	START PIN	FINISH PIN	MARGIN TAPE (mm)	TUBE		REMARK
							Spin	Fpin	
N1	2UEW ϕ 0.37*2	22	1	4	2	x			繞滿二層
E1	背胶銅箔 0.025T*6W	1.2	1	?	6	x			6W 背胶銅箔
N2	TEX ϕ 0.65*2	5	1	OB	OA	x	YES	YES	繞滿一層
N3	TEX ϕ 0.65*2	5	2	OB	OA	x	YES	YES	繞滿一層
E2	背胶銅箔 0.025T*6W	1.2	1	?	6	x			6W 背胶銅箔
N4	2UEW ϕ 0.37*2	11	2	2	1	x	x	x	繞滿一層
N5	2UEW ϕ 0.2*3	7	2	6	5	x			居中密繞

NOTE:

- Bobbin: PQ2620 6+6 PIN Core: PC44.
- Lp 4-1: 650uH Lk: <60
- Hi-pot: 3.6 KV / 60Hz / 5mA 2S (P to S)
3.6KV / 60Hz / 5mA 2S(S to C)
- Cut off: PIN 3.7.8.9.10.11.12
- Cut off half: PIN :2 鐵心 GAP: 研磨
- 樣品: 含浸 PCS, 不含浸 PCS.
- 料號: 12V (注意: 料號請貼在側面, 不要貼在頂部) 樣品請註明鐵心材質
- OA 靠 PIN7 從頂部出線長 35mm 白色 TUBE, OB 平行骨架底部凹槽出線長 20mm 黑色 TUBE 再從剝頭鍍錫部位折彎, OA, OB 需成形, 剝頭鍍錫 5mm 如: 圖 1

PIN 1

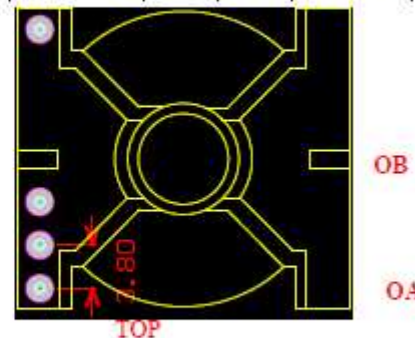

Sales and Technical supports

- Design-in documents:
 - Reference design schematics
 - PCB layout Gerber files
 - BOM
 - Mathcad external component calculation tool
- Sales contact: Sales@nem.com.tw
- FAE contacts: FAE@nem.com.tw