

ElektorWheellie

The electronics behind a rather special kind of vehicle

Chris Krohne (Germany)



In this first article describing our DIY self-balancing single-axle vehicle we look at the electronics modules. An ATmega32 processes the controls and sensor data and drives the two electric motors via power driver stages. It keeps the vehicle balanced and can drive it in any desired direction at any desired speed from stationary to about 11 mph.

The electronics in the ElektorWheellie processes input signals from a control potentiometer, an acceleration sensor and an inclination sensor. It con-

trols the magnitude and direction of the torque applied to the wheels via two motors using PWM signals and MOSFET drivers. The sensors provide

enough information to allow the vehicle to maintain its balance over its full range of speeds, and it can even spin on the spot.

Characteristics

- Two 500 W DC drive motors
- Two 12 V lead-acid AGM batteries, 9 Ah
- Two fourteen-inch wheels with pneumatic tyres
- H-bridge PWM motor control up to 25 A
- Automatic power off on dismount
- Fail-safe emergency cutout
- Battery charge status indicator
- Maximum speed approx. 11 mph (18 km/h)
- Range approximately 5 miles (8 km)
- Weight approximately 35 kg

Sensors:

- Invensense IDG300 (or IDG500) gyroscope
- Analog Devices ADXL320 accelerometer
- Allegro ACS755SCB-100 current sensor

Microcontrollers:

- ATmega16 (motor control)
- ATtiny25 (current monitoring)

Compiler:

- BASCOM-AVR Basic compiler

A delicate balance

For the vehicle to be able to balance successfully it is essential that the sensors provide reliable information about the inclination of the platform and its angular velocity. This is in addition, of course, to ensuring that the control system, motor drivers and motors themselves are properly designed.

Balancing itself is relatively straightforward. If the rider leans forwards the platform tilts and the motors are driven so as to bring the whole system (vehicle plus rider) back towards balance. That means that the rider's feet are pushed forwards under the centre of gravity of the whole system, opposing the rider's leaning and reducing the tilt angle.

The system therefore tilts as a whole, which requires both a strong mechanical construction and a carefully designed and experimentally tested filter function. The damping characteristic of the filter is set just short of the point where the system starts to become unstable.

Steering is performed by applying differential acceleration or braking to the two motors. Note that at higher speeds the tightness of the turning circle has to be limited. In the ElektorWheelite the limit is set so that the rider cannot overturn the vehicle by trying to change direction suddenly.

No motor has an infinite amount of power. In the case of the ElektorWheelite there is the potential for serious consequences for the rider if a motor does not have enough power headroom to allow for balance to be maintained. For this reason the motors are normally only driven up to approximately 70 % of their maximum power. This keeps a little in reserve so that, when top speed is reached, the wheels can be given a small extra acceleration. This throws the rider back slightly, which automatically leads to a reduction in speed. Leaning back slows the vehicle down, leaning forwards speeds it up.

The drive train is based on two 500 watt DC electric motors, with power being provided by two 12 V AGM (absorbed glass mat) lead-acid batteries. Most of the electronics is located on a control board, with a sensor board mounted on it.

The control system uses dynamic stabilisation. The vehicle senses the attitude of its platform in an analogous way to the human sense of balance. If the platform starts to tilt forwards or backwards, the vehicle makes a proportional acceleration to oppose the tilt using both motors. By applying different amounts of drive to the two motors, the vehicle can turn.

Block diagram

Central in the block diagram of the attitude control and motor drive unit shown in **Figure 1** is an Atmel ATmega32 microcontroller. This has two PWM outputs that are used to drive the two 24 V DC motors via a pair of MOSFET H-bridges. A second microcontroller, an Atmel ATtiny25 this time, monitors the motor current using a Hall effect sensor. If an excessive current (over 80 A) should flow because of a short circuit in the system, the ATtiny25 interrupts the 15 V power supply to the H-bridge driver circuitry using the shutdown input of its regulator. In the event of a total failure of the control electronics the battery current can also be interrupted using a purely electromechanical emergency stop device, providing the ultimate protection against the vehicle running out of control.

In normal operation the ATtiny25 will also notify the ATmega32 when the motor current exceeds a preset value of around 25 A, which will cause the

controller to attempt to reduce the current by limiting the range of the PWM control signals.

The ATmega32 receives sensor inputs

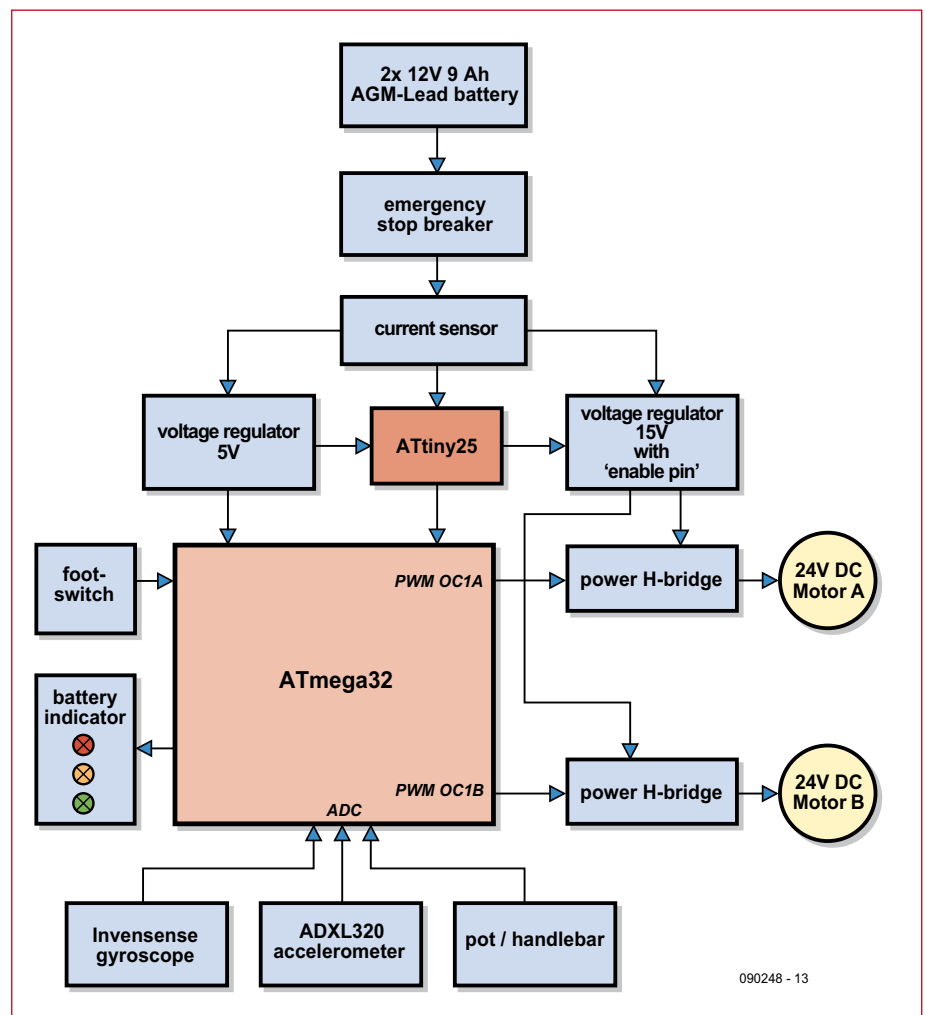

Figure 1. Block diagram of the motor controller.

using its ADC (analogue-to-digital converter) from the gyroscope and the accelerometer on the sensor board and from the high-reliability potentiometer that is mechanically connected to the steering control of the ElektorWheelite. The ADC inputs are sampled around 100 times per second. As a further safety feature a footswitch is connected to an input of the ATmega32. If this switch is not held down (because the rider has dismounted) the microcontroller will interrupt the motor current after two seconds. This also helps to prevent the vehicle from running away on its own. The battery voltage is also monitored by the ATmega32 using its ADC, and used to drive three LEDs that indicate the remaining available running time to the rider.

Sensors and stabilisation

The attitude sensors are mounted on their own small printed circuit board that plugs into the main control board. **Figure 2** shows the circuit of the sensor board, which includes an InvenSense IDG300 [1] two-axis gyroscope and an Analog Devices ADXL320 [2] two-axis accelerometer. Voltage regulator IC3 provides the required 3 V supply for the sensors; this voltage also serves as the reference voltage for the ATmega32's A/D converter on the main board. The output of the gyroscope is a voltage proportional to the rate at which it is turning (its angular velocity). If the platform is tipping rapidly there will be a large and rapid swing in the gyroscope's output voltage. When stationary the output voltage of the gyroscope is approximately half its supply voltage. The accelerometer measures the component of the acceleration due to gravity in its own plane. If the sensor is tilted this will affect the angle at which gravity acts relative to the device, which therefore operates as an inclination sensor, delivering an output depending on the attitude of the platform. To obtain the best possible stability it

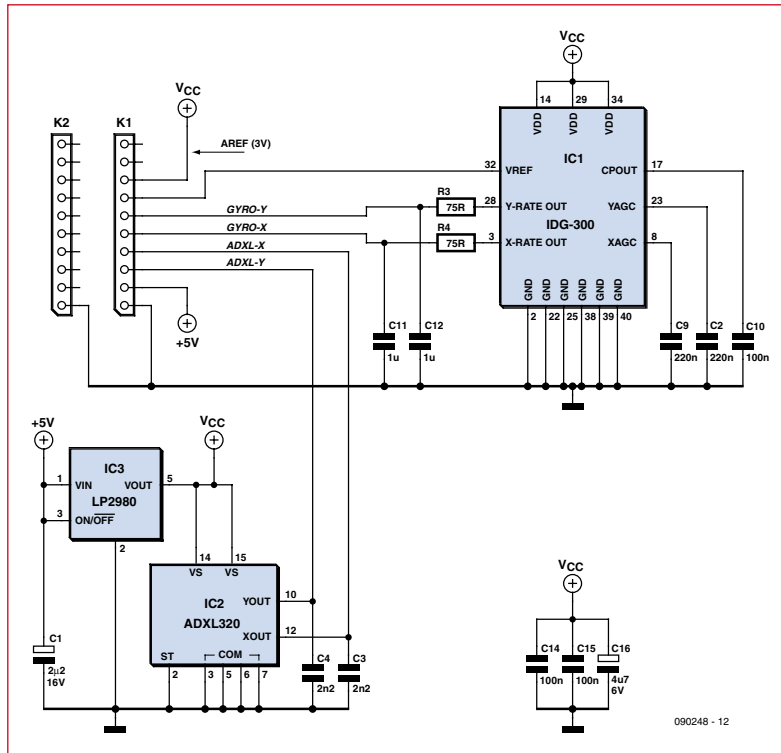

Figure 2. Circuit diagram of the sensor board with gyroscope and accelerometer.

is important to determine the attitude of the platform as accurately as possible at each instant in time. The output of the accelerometer is therefore integrated over a relatively long time period to obtain a smoothed signal. To this smoothed result is added the output of the gyroscope, in proportions that have been empirically optimised. The acceleration signal delivered to the motor controller is calculated as a preset linear combination of the attitude error (the difference between the actual inclination angle and the target inclination angle) and the angular velocity with which the platform is tipping. In essence, the greater the attitude error and the greater the angular velocity, the greater the motor acceleration required for stabilisation.

Motor control

The circuit diagram of the main printed circuit board in **Figure 3** contains all of the control circuitry of the ElektorWheelite, including the power driver stages. Only the attitude sensors, as mentioned above, are mounted on a separate board. It is fairly easy to identify the components corresponding to the various parts of the block diagram. In the centre is the ATmega32, clocked at 16 MHz. It is directly connected to 10-way in-system programming (ISP) con-

nectors K4 and to the three LEDs, LED1 to LED3, that show the battery status. The sensor board is connected to K2 on the control board. The X-axis and Y-axis outputs of the sensors are connected to A/D converter inputs ADC2 to ADC5 on the ATmega32, and pin 32 (AREF) is fed with 3 V from the voltage regulator on the sensor board. The 3 V supply is also taken to K3 where it provides power to the steering potentiometer. The wiper of this potentiometer thus provides a voltage to analogue input ADC6 on the ATmega32 that depends on the position of the steering control. Analogue

input ADC0 measures the battery voltage via the voltage divider comprising R10 and R11, and ADC7 monitors the position of the footswitch via K3. The fault detection signal (CURRFLAG) is taken to pin 16 (INT0) of the ATmega32 from the ATtiny25 current monitor IC10, which in turn is connected to current sensor IC5. IC5 is an integrated Hall effect sensor from Allegro Microsystems offering linear operation up to 100 A. CURRFLAG is set if the current reaches approximately 25 A and causes the motor current to be limited by bounding the range of the PWM drive signal. We now turn to the output signals of the ATmega32. The result of processing the various inputs to the microcontroller appear as the signals on the four outputs PWM-L, PWM-R, CW/CCW-A and CW/CCW-B, on pins 18 to 21. CW/CCW-A and CW/CCW-B are logically combined with the PWM outputs PWM-L and PWM-R in IC8 and IC9 is such a way that they determine the direction of rotation of the motors, while the PWM signals control the current delivered to the motors via the H-bridges. Each motor thus has two control signals and a complete H-bridge driver,

Figure 3. Circuit diagram of the main board, including control and power electronics.

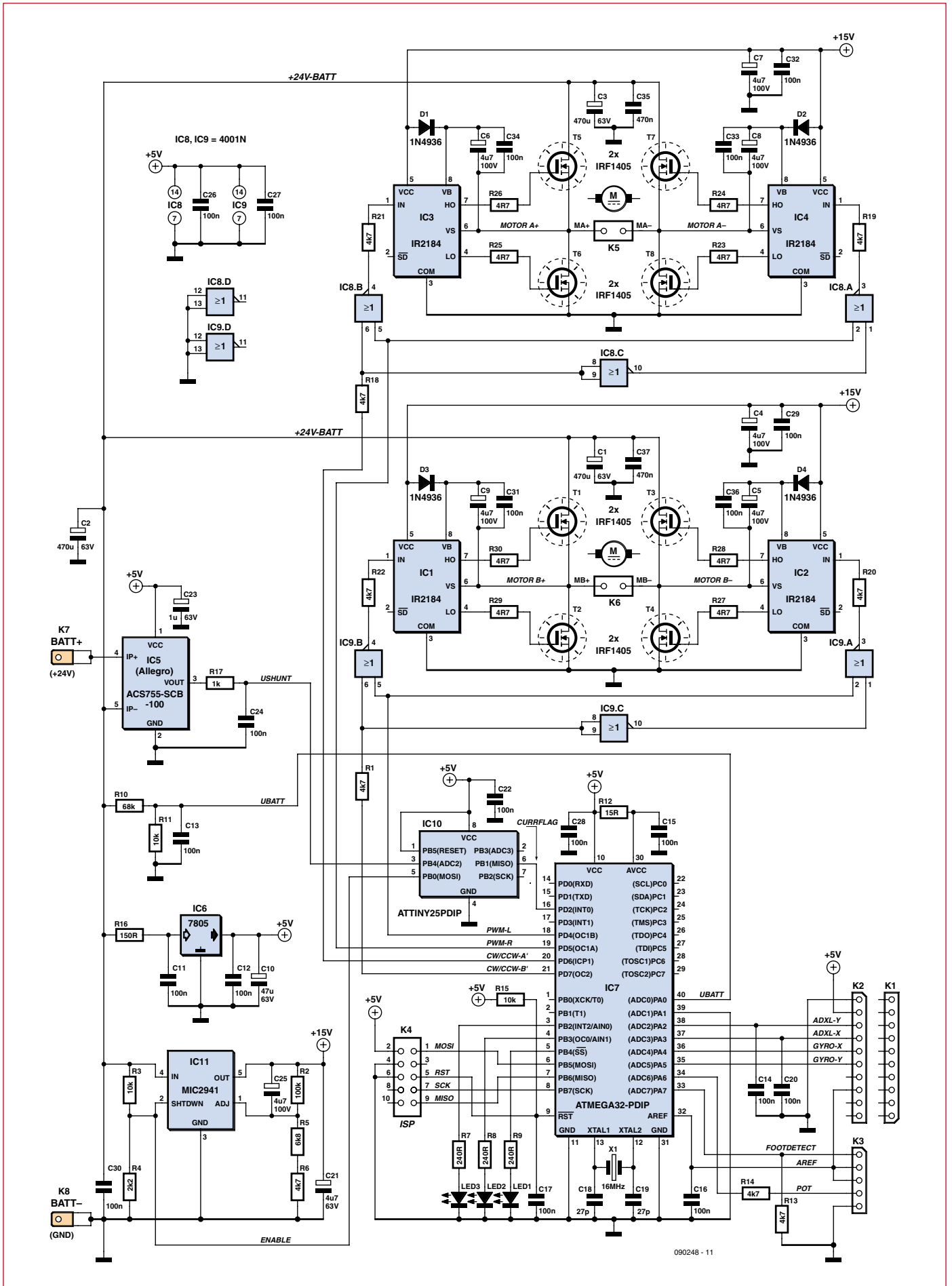

090248 - 11

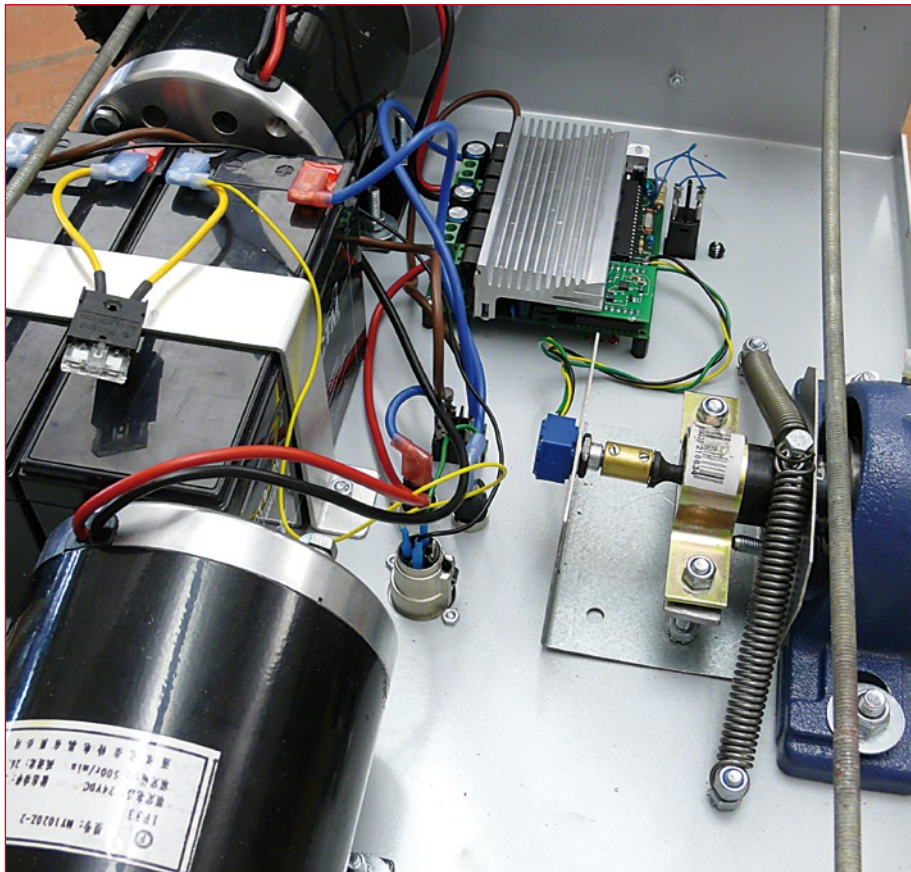

Figure 4. The batteries and electronics module are mounted on the underside of the metal chassis.

and each H-bridge is composed of two half-bridge driver ICs type IR2184 and four IRF4105 MOSFETs. The left wheel motor is driven by IC1, IC2 and T1

to T4, while the right wheel motor is driven by IC3, IC4 and T5 to T8. The MOSFET bridge circuits are powered from the 24 V supply derived from

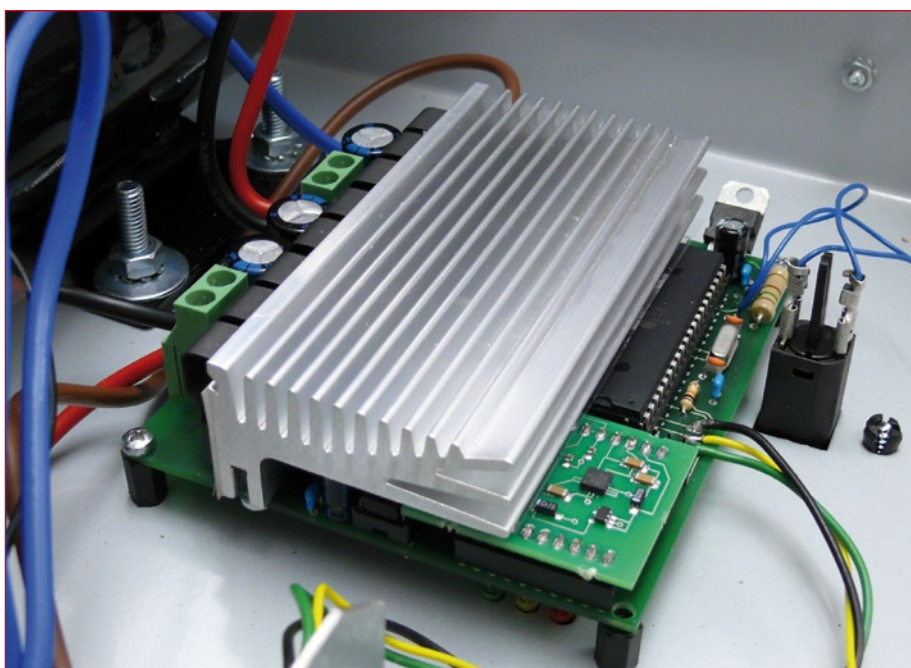

Figure 5. The compact electronics module comprises the main board with heatsink and sensor daughter board.

the two lead-acid AGM batteries in series via current sensor IC5. The half-bridge driver ICs receive their own 15 V supply from the MIC2941 voltage regulator IC11. This IC has a shutdown input (pin 2) that is connected to the 'enable' output signal from the current monitoring circuit (pin 5 on IC10). When excess current is detected this signal shuts down the regulator and hence also the bridge driver ICs. The MOSFETs then block and the motor current is interrupted. All the other ICs are powered with 5 V from IC6, a standard regulator.

A compact module

Figure 4 shows the metal chassis of the vehicle. The electronics module (Figure 5), comprising the main board (Figure 6) and the sensor daughter board (Figure 7) is mounted on the underside of the platform.

The eight MOSFETs are positioned in a row on the reverse of the main board and are cooled using a specially-designed common heatsink. The heatsink is bolted to the printed circuit board and the MOSFETs are held on to the heatsink using spring clips. A self-adhesive thermally conductive sheet between the MOSFETs and the heatsink provides electrical isolation.

The main board contains only leaded devices, in contrast to the SMD-populated sensor board. The printed circuit board layouts are as usual available for free download from the project web pages [3] as PDFs, along with associated parts lists.

Software

The firmware for the two microcontrollers was written using BASCOM-AVR. Figure 8 gives an overview of the main functions involved in controlling the motors, which will be described briefly below.

Function Init:

This function initialises and configures Timer0, Timer1 and the PWM outputs, initialises variables and calibrates the gyroscope, accelerometer and steering potentiometer.

Function Get_Angle:

This function reads values from the analogue inputs (gyroscope, ADXL320, potentiometer, battery voltage and footswitch). The gyroscope, ADXL320 and battery voltage readings are integrated over a period of fifty samples.

Then the angular velocity (Angle_Rate) and absolute angle (Tilt_angle) are calculated.

Function Filter:

This function calculates the change in acceleration required of the motors (Balance_Diff) and the overall motor speed (Drive_Speed).

Function Process:

This function uses the current speed and the position of the steering control to calculate the necessary modification to the speed of the motors to turn the vehicle as requested. It checks to see if the ATtiny25 has reported an overcurrent condition and reduces the motor speed (Drive_speed) if needed. The overcurrent condition and footswitch alarm states are indicated by the LEDs flashing.

The function calls Get_speed_batt.

Function Get_speed_batt:

This function adds a value Angle_Correction in the case where the maximum speed is exceeded. It also sets the state of the three LEDs according to the battery voltage.

Function PWM_Out:

This function configures the PWM outputs according to the acceleration required for motors A and B, and sets the other outputs to reflect the desired rotation direction.

The function also imposes a limit on the maximum drive power (PWM_MAX).

Function interrupt:

This function is called 100 times per second. In turn it calls Get_Angle, Filter, Process and PWM_Out.

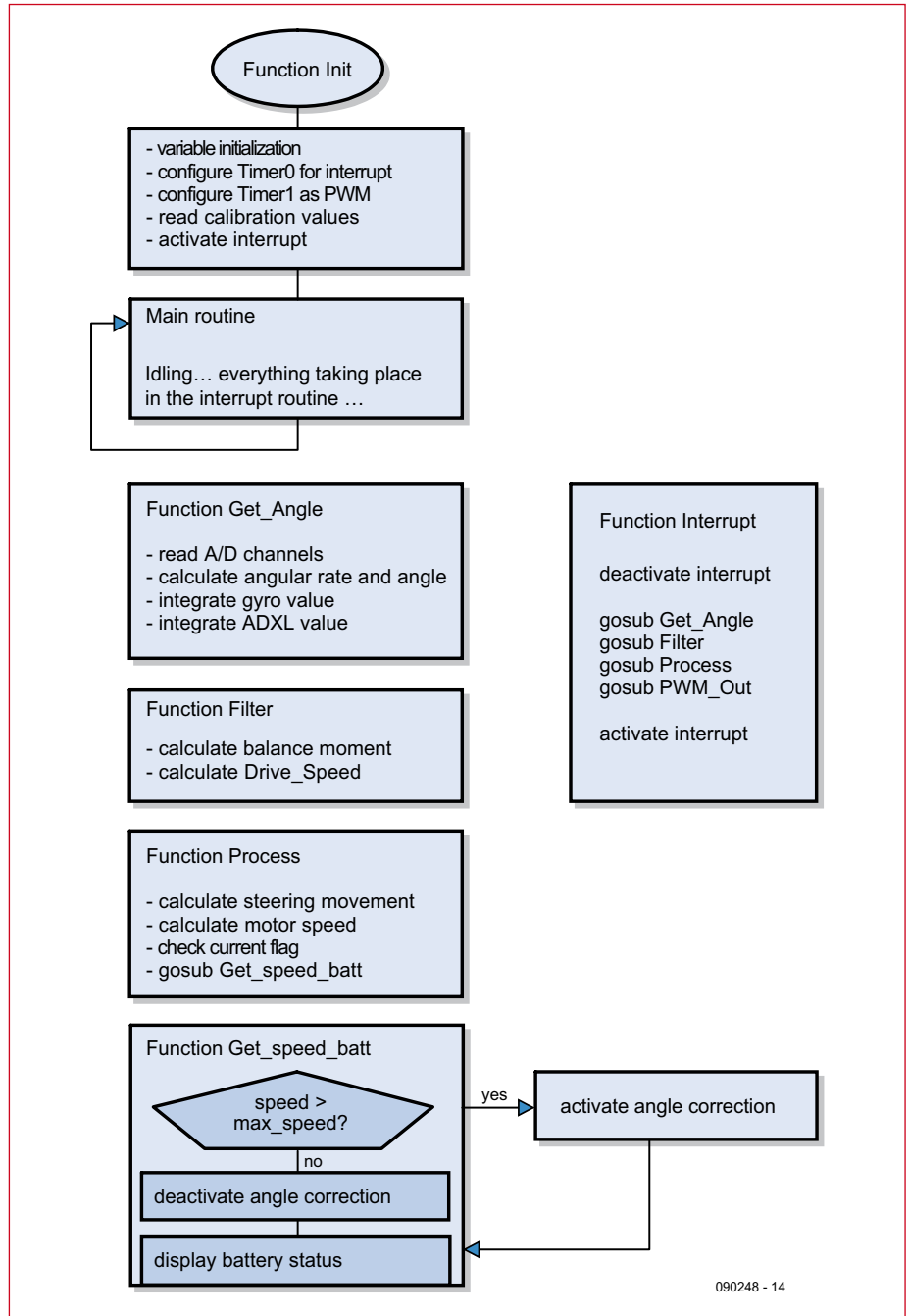

090248 - 14

Figure 6. Control software functions.

Mechanics

In the second and final part of this series we will look at the mechanics of the ElektorWheellie. We will describe the construction of the vehicle and outline how it is assembled and wired. Finally we will give a few tips on how to drive the vehicle and some further practical suggestions.

(090248-1)

Internet links

- [1] http://www.invensense.com/shared/pdf/DS_IDG300.pdf
- [2] http://www.analog.com/static/imported-files/data_sheets/ADXL320.pdf
- [3] <http://www.elektor.com/090248>

DISCLAIMER & CAUTIONS

- **The ElektorWheellie vehicle is an Open Development. The buyer is free to make changes and modifications to the hardware or software of the ElektorWheellie kit, at his/her own risk.**
- **The use of ElektorWheellie on public roads or in public spaces may be illegal and/or subject to legislation and type approval. No type approval has been applied for and owners are advised to check local or national legislation for any use other than on private land, or with the land owner's permission. Elektor International media BV accepts no responsibility in this respect whatsoever.**
- **Under the terms of an Open Development Elektor International Media cannot be held liable for any damages, penalties or injuries caused by, or arising from, the use, ownership or assembly of the ElektorWheellie vehicle.**