



# LED Driver Demo Board

Input 170-265VAC // Output 100mA, 150V (15W)

## General Description

The AN9920ADB4 demo board is the offline switching mode LED driver, using the AN9920A, an integrated 3-pin constant-current buck regulator IC. The AN9920A integrates a high voltage switching MOSFET and can operate directly from the rectifier AC line with a nominal of 220VAC. The current in the LED string is internally programmed to 100mA. Design is ideally suited for driving strings of about 42 LEDs in series. The AN9920ADB4 is an average-mode constant current-controlled buck converter operating with fixed off-time of 10us. Its fixed off-time control scheme provides good stability and tight regulation of the LED current throughout the input AC line voltage range. The LED current accuracy is almost insensitive to the passive component tolerances, such as the output filter inductance or the timing resistor. Accurate current control is only achieved with continuous conduction of the filter inductor, i.e. when the LED current is greater than the inductor ripple current amplitude.

Specifications	
Input AC Voltage	170 to 265V, 60Hz
Output Voltage	90 to 150V
Output Current	100mA +0/-15%
Power Factor	> 60%
Efficiency	> 80%
100 Hz Output Current Ripple	< 20%
Output short circuit protection	Yes
Output overvoltage, open circuit protection	Yes
Switching frequency	About 80kHz ( depends on the input and output voltage)
Operating Temperature	-25 ... +50 °C
Dimensions	35 x 15 x 25 mm

The AN9920ADB4 features protection from an output short circuit condition. Open LED protection is inherent, since the output filter capacitor can accept the full rated rectified AC line voltage.

Please, note that the demo board is not CISPR15 compliant. An additional input EMI filter circuit is required to make the board meet conducted electro-magnetic emission limits.

This demo board intended for evaluation and testing purposes only, not for high volume and/or end product usage.

## Warning!

*Working with this board can cause serious bodily harm or death. Connecting the board to a source of line voltage will result in the presence of hazardous voltage throughout the system including the LED load.*

*The board should only be handled by persons well aware of the dangers involved with working on live electrical equipment. Extreme care should be taken to protect against electric shock. Disconnect the board before attempting to make any changes to the system configuration. Always work with another person nearby who can offer assistance in case of an emergency. Wear safety glasses for eye protection.*

*The electrolytic capacitor carries a hazardous voltage for an extended time after the board is disconnected. Check the capacitor voltage before handling the board.*



### Board Connections

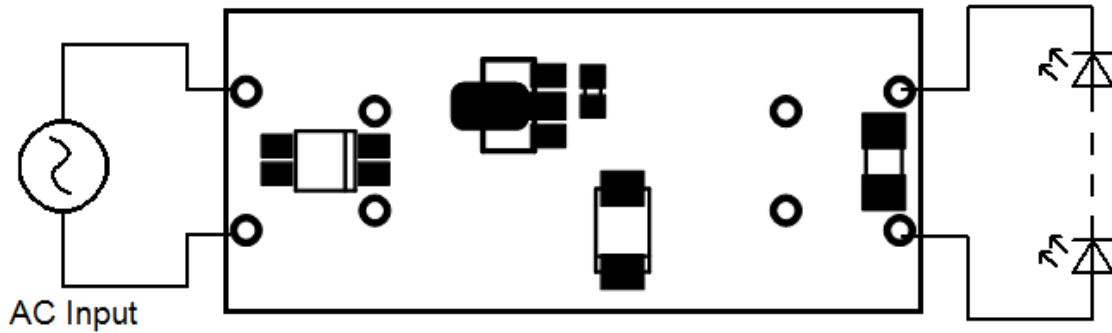

### Connection Instructions

1. Carefully inspect the board for shipping damage, loose components, etc, before making connections.
2. Connect the board to the line and load as shown in the diagram. Be sure to check for correct polarity when connecting the LED string to avoid damage to the string. The LED string voltage can be anything between 90 and 150V.
3. Energize the mains supply.

### Schematic Diagram

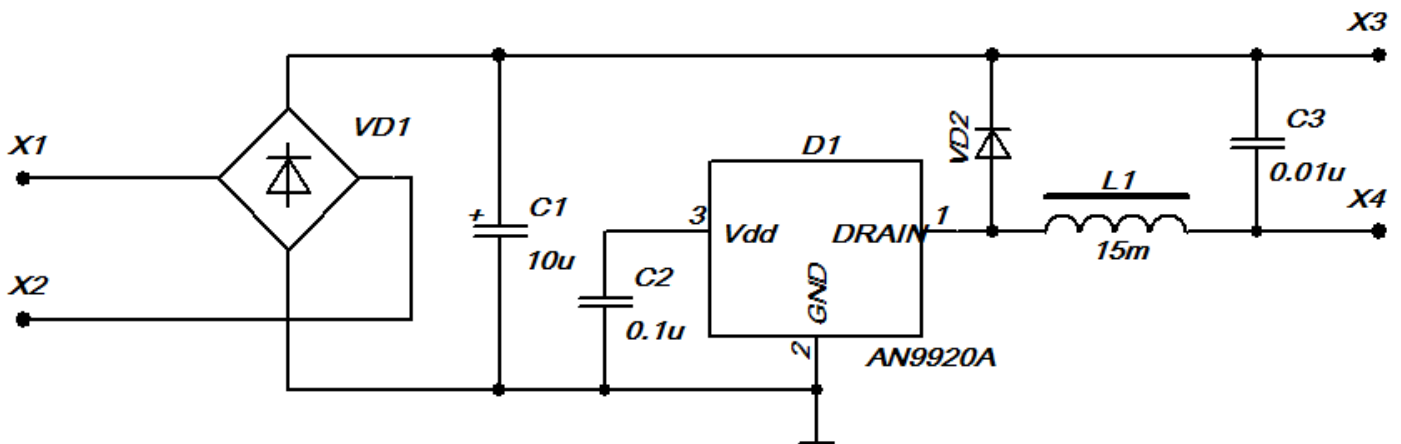



### Typical Characteristics

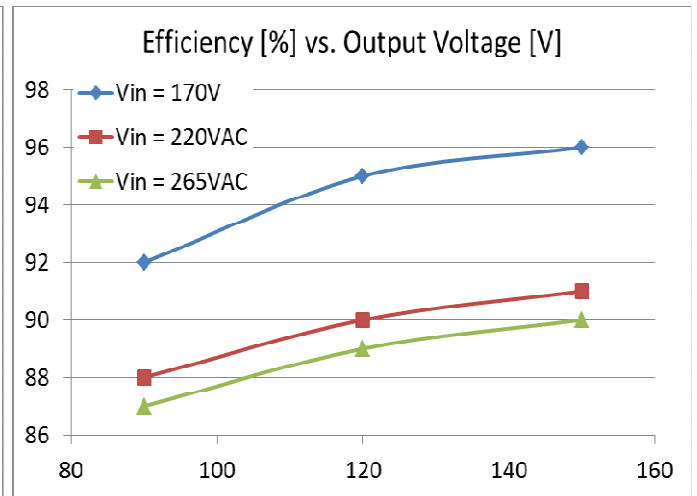
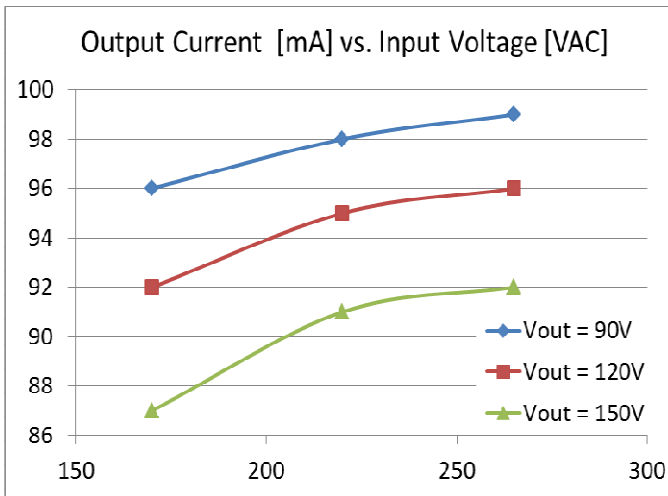

### Waveforms (220VAC input)

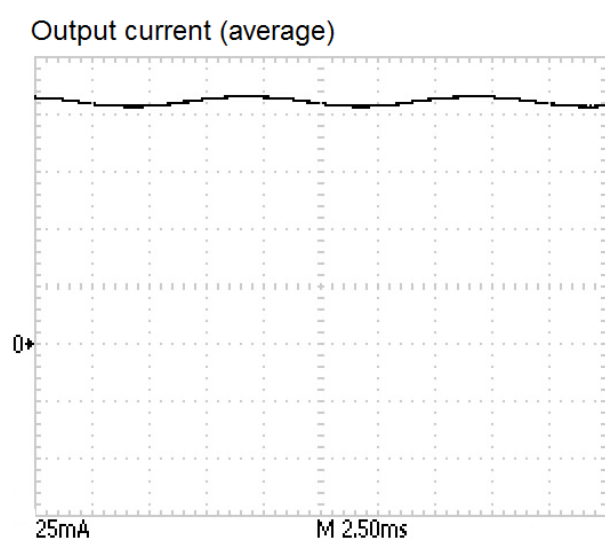
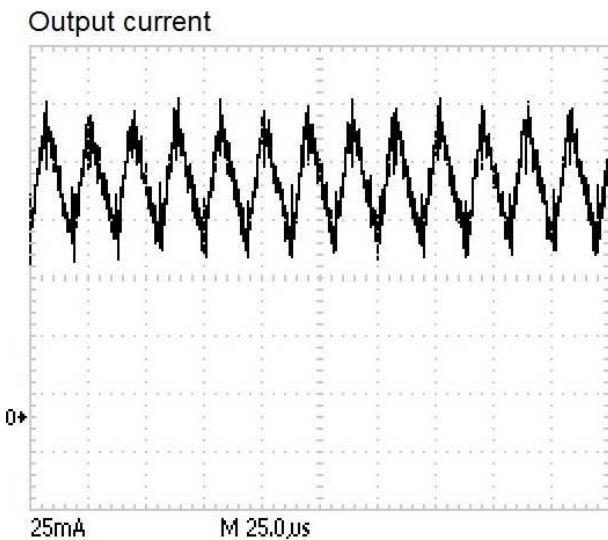
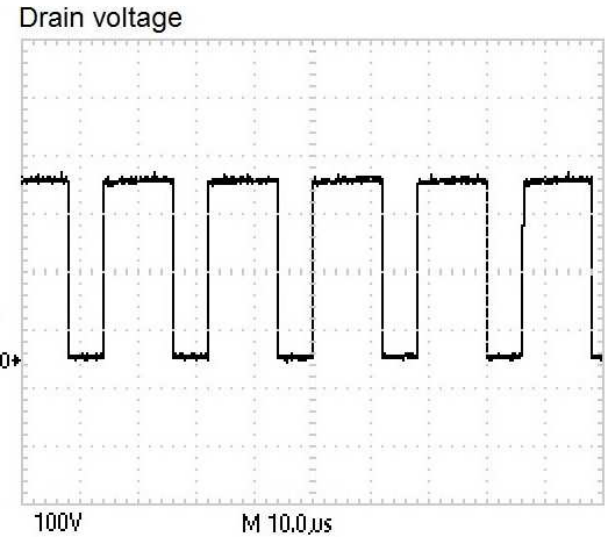
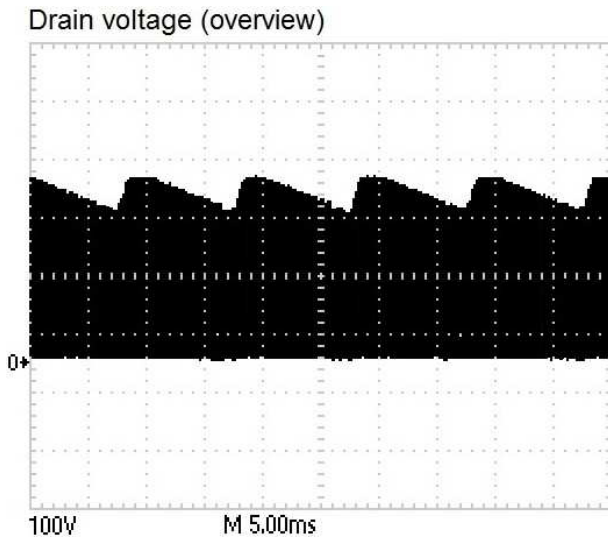



PCB Layout

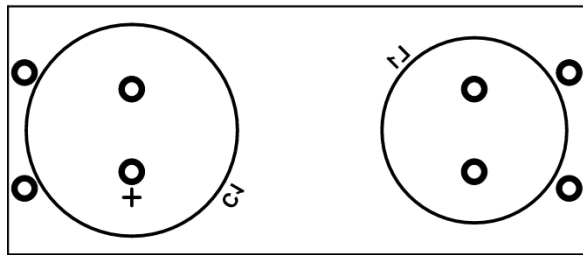
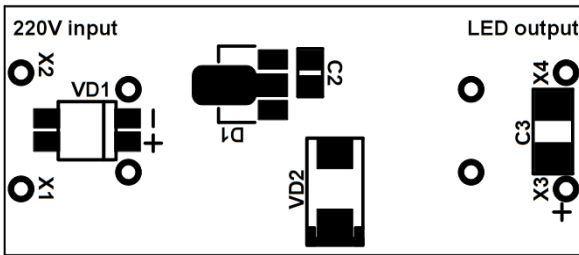
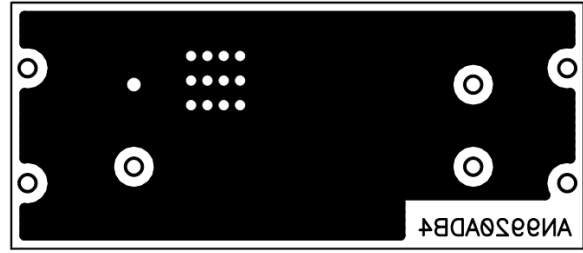
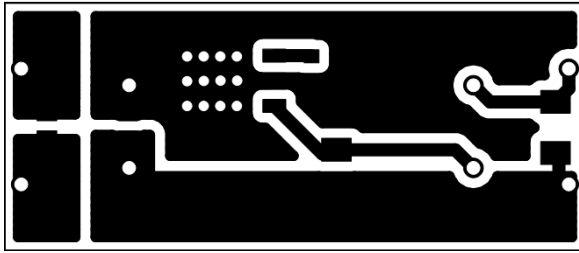

Bill of Materials

Qty	REF	Description	Manufacturer	Product Number
1	C1	Cap Alu 6.8uF 400V	Rubycon	400LLE6R8MEFC10X16
1	C2	Cap X7R 0603 0.1uF 16V	-	-
1	C3	Cap X7R 1206 0.01uF 630V	-	-
1	D1	IC LED Driver	Angstrom	AN9920A
1	L1	Inductor 15mH 0.14A	Sumida	RCH114NP-153KB
1	VD1	Rect Bridge 250VAC 0.5A	Diotec	MYS250
1	VD2	Diode UltraFast 600V 1A	ST	STTH1R06A
4	X1 ... X4	PCB pads	-	-