

40V Boost Converter for LED driver / TFT Bias / USB Power

DESCRIPTION

The ETA1617 is a high efficiency step-up converter with an internally integrated 40V power MOSFET. It runs with an optimal 0.8MHz frequency that enables use of small external components while still providing best efficiencies. It has an internal current limit as high as 1A, and it can drive up to 10 LEDs at 50mA output current. The incorporated 25-100KHz true PWM-Dimming feature by EN pin can be used to digitally program the LED current. For maximum protection, the ETA1617 has an internal OVP protection at 38V to prevent the chip from damages when the LED string is not connected to the output.

ETA1617 is available in a space-saving SOT23-6 package.

ORDERING INFORMATION

PART ID	PACKAGE	TOP MARK
ETA1617S2G	SOT23-6	EFYW (YW: Date Code)

FEATURES

- Up to 91% Efficiency (6 LEDs)
- Drive up to 10 LEDs with 50mA
- Drive up to 40 LEDs in total
- 38V OVP protection
- True PWM Brightness Control
- 200mV Feedback Voltage
- 1A current limit
- SOT23-6 Package

APPLICATIONS

- Cellphone and Smartphone
- MID or Tablet PC
- TFT-bias for LCD screen
- Power for OLED
- LED torch
- Satellite Set Top Box

TYPICAL APPLICATION

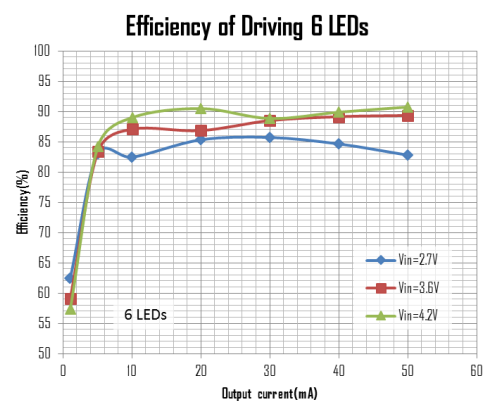
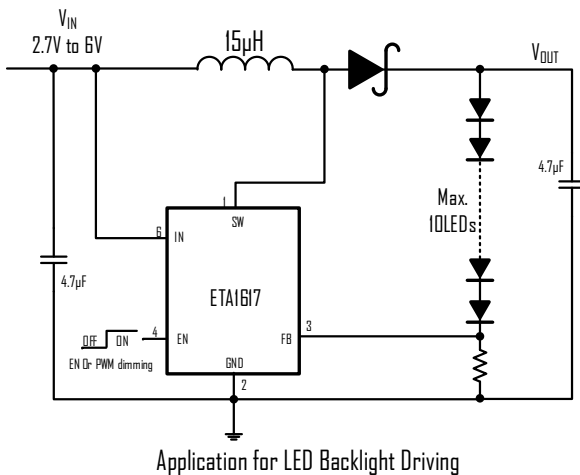

PIN CONFIGURATION

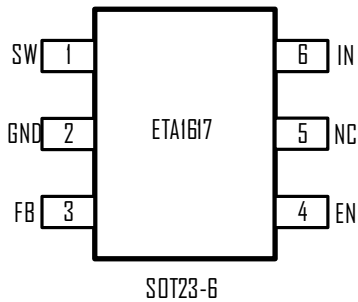

ABSOLUTE MAXIMUM RATINGS

(Note: Exceeding these limits may damage the device. Exposure to absolute maximum rating conditions for long periods may affect device reliability.)

SW Voltage.....	-0.3V to 40V
All Other PIN Voltages.....	-0.3V to 6.5V
SW to ground current	Internally limited
Operating Temperature Range	-40°C to 85°C
Storage Temperature Range	-55°C to 150°C
Thermal Resistance	θ_{JA} θ_{JC}
SOT23-6.....	100.....50°C/W

ELECTRICAL CHARACTERISTICS

($V_{IN} = 3.6V$, unless otherwise specified. Typical values are at $T_A = 25^\circ C$.)

PARAMETER	CONDITIONS	MIN	TYP	MAX	UNITS
Input Voltage Range		2.7		6	V
FB Feedback Voltage	$V_{IN} = V_{CTRL} = 3.6V$	194	200	206	mV
FB Input Current				2	μA
Quiescent Current at IN	Switching at $I_{out}=0$		1.0	1.8	mA
	No Switching		0.2		mA
Shutdown Supply Current at IN	$V_{EN}=GND$		0	5	μA
Switching Frequency	$V_{IN}<4.3V$		0.8		MHz
Maximum Duty Cycle		90	93		%
NMOS Switch On Resistance	$I_{SW} = 100mA$		0.44		Ω
NMOS Switch Current Limit	$V_{IN} = 3.6V$, 10 LEDs		1.0		A
SW Leakage Current	$V_{SW}=0$ or 20V, $V_{EN}=GND$			10	μA
EN Input Current			0.1	1	μA
EN Input Low Voltage				0.6	V
EN Input High Voltage		1.2			V
PWM dimming frequency		25		100	KHz
Thermal Shutdown	Rising, Hysteresis=10°C		165		°C

PIN DESCRIPTION

PIN #	NAME	DESCRIPTION
1	SW	Inductor Connection. Connect an inductor Between SW and IN.
2	GND	Ground Pin
3	FB	Feedback Input for Current. Connect an external resistor FB to GND to set I_{out}
4	EN	Control pin for the IC. It is a multi-functional pin for enable control, PWM dimming
5	NC	Not connected, leave this PIN floating
6	IN	Input Supply pin. Bypass with a 4.7 μF or larger ceramic capacitor to GND

TYPICAL CHARACTERISTICS

(Typical values are at TA = 25°C unless otherwise specified.)

Efficiency of Driving 6 LEDs

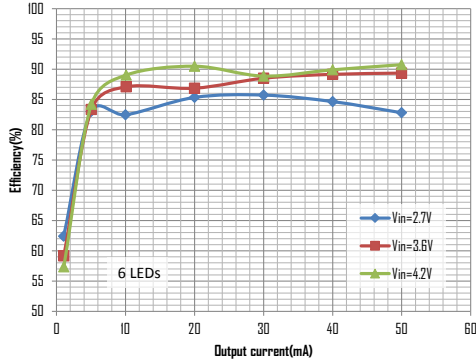

Efficiency of Driving 10 LEDs

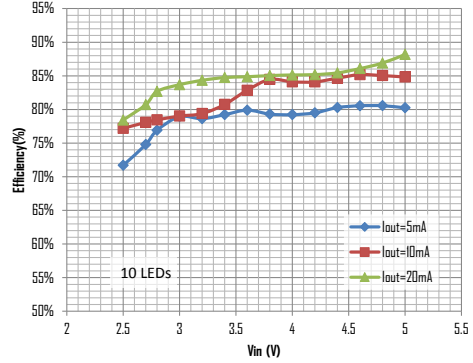

Vfb Vs PWM Dimming Duty Cycle

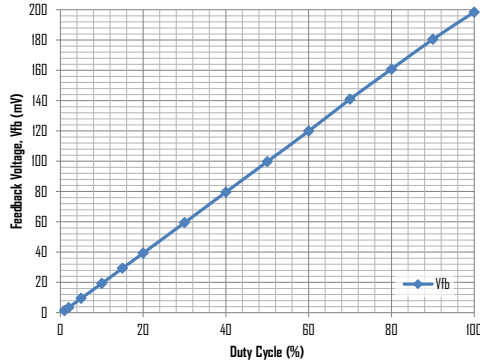

Efficiency of Boost to 5V

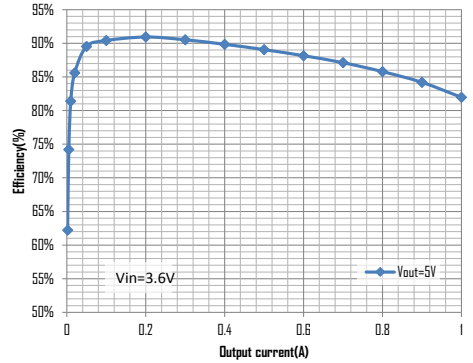

Switching Waveform
VIN=3.6V, 10LEDs, IOUT= 20mA

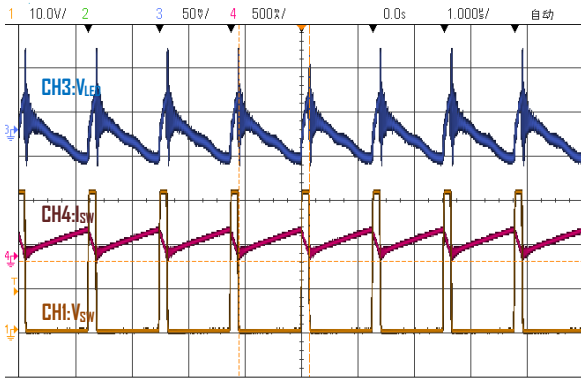

Switching Waveform
VIN=3.6V, 10LEDs, IOUT= 40mA

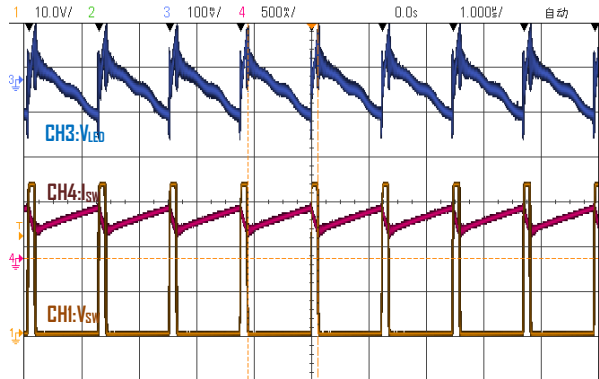

USB Power Application Circuit

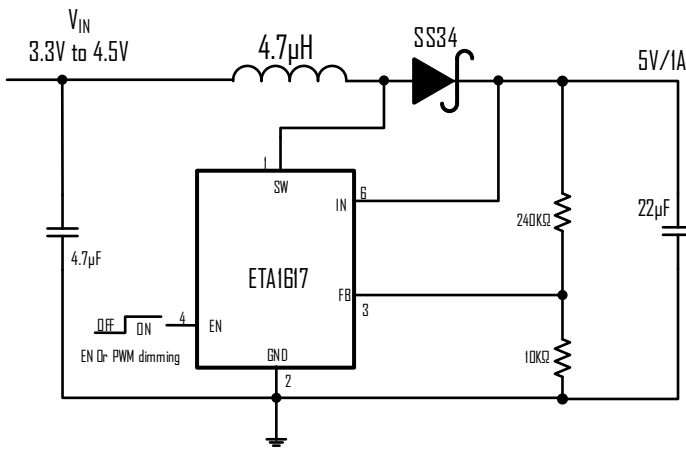

Note: The Pin6, Vin Pin of ETA1617 is connected to 5V, not the battery input.

TFT Bias Application Circuit

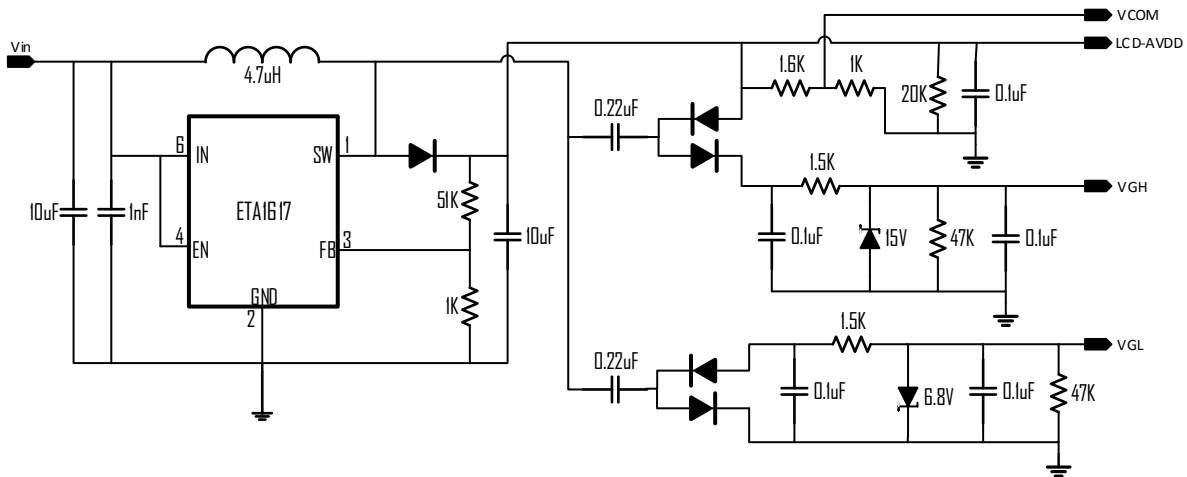

FUNCTIONAL DESCRIPTIONS

The ETA1617 is a high efficiency boost LED driver with a small package size. The device is ideal for driving 2-25 LEDs for backlight application in smartphone and 7-inch tablet PC. The device integrates a 38V/1A switch FET and operates in pulse width modulation (PWM) with a 0.8MHz fixed switching frequency. For operation details, please check the block diagram in the “Block Diagram” chapter. The duty cycle of the converter is set by the error amplifier output and the current signal applied to the PWM control comparator. The feedback loop regulates the FB pin to a low reference voltage (200mV typical), reducing the power dissipation in the current sense resistor.

Output Open Circuit Protection

Output open circuit protection circuitry prevents IC damage as the result of output open circuit (e.g. LED string absence). The ETA1617 monitors the voltage at the SW pin and FB pin during each switching cycle. The circuitry turns off the switch FET and shuts down the IC when both of the following conditions persist for 8 switching clock cycles: (1) the SW voltage exceeds the VOVP threshold, which is 38V and (2) the FB voltage is less than half of regulation voltage. As a result, the output voltage falls to

the level of the input supply. The device remains in shutdown mode until it is enabled by toggling the EN pin logic. The output voltage plus the 200mV reference voltage cannot exceed the minimum OVP threshold or $OUTPUT\ VOLTAGE + 200\ mV \leq VOVP(MIN)$.

Shutdown

The ETA1617 enters shutdown mode when the EN voltage is logic low for more than 3ms. During shutdown, the input supply current for the device is less than 1µA (max). Although the internal FET does not switch in shutdown, there is still a DC current path between the input and the output through the inductor and Schottky diode.

For LED driving application, the minimum forward voltage of the LED array must exceed the maximum input voltage to ensure that the LEDs remain off in shutdown. However, in the typical application with two or more LEDs, the forward voltage is large enough to reverse bias the Schottky and keep leakage current low.

LED Driving Current Setting

The FB voltage is regulated by a low 0.2V reference voltage. The LED current is set externally using a current-sense resistor in series with the LED string. The value of the RSET is calculated using Equation 1.2:

$$I_{LED} = 0.2 / RSET \quad (1.2)$$

Where

I_{LED} = output current of LEDs, RSET = current sense resistor

The output current tolerance depends on the FB accuracy and the current sensor resistor accuracy.

PWM Dimming Control or Output Voltage Programming

When the CTRL pin is constantly high, the FB voltage is regulated to 200mV typically. However, the EN pin allows a PWM signal to reduce this regulation voltage; therefore, it achieves LED brightness dimming or output voltage programming (only to make output voltage lower). The relationship between the duty cycle and FB voltage is given by Equation 2.

$$V_{FB} = Duty * 200\ mV \quad (2)$$

Where

Duty = duty cycle of the PWM signal, 200 mV = internal reference voltage

This PWM dimming eliminates the audible noise which often occurs when the output current is pulsed in replica of the frequency and duty cycle of PWM control. Unlike other scheme which filters the PWM signal for analog dimming, ETA1617 regulation voltage is independent of the PWM logic voltage level which often has large variations. For optimum performance, use the PWM dimming frequency in the range of 25kHz to 100kHz.

APPLICATION INFORMATION

Inductor Selection

Using an inductor with a smaller inductance value forces discontinuous PWM when the inductor current ramps down to zero before the end of each switching cycle. This reduces the boost converter's maximum output current, causes large input voltage ripple and reduces efficiency. Large inductance value provides much more output current and higher conversion efficiency. For these reasons, a 15 μ H to 22 μ H inductor value range is recommended. A 15 μ H inductor optimized the efficiency for most application while maintaining low inductor peak to peak ripple. Below table lists the recommended inductor for the ETA1617.

Recommended Inductors for ETA1617

L(μ H)	Saturation Current (mA)	Vendor
4.7- 15	>1500	Sunlord

Schottky Diode Selection

A high-speed rectifying Schottky with low parasitic capacitance is recommended for ETA1617 for maximum efficiency due to its high switching frequency. The diode average and peak current rating must be larger than the average output current and peak inductor current to ensure reliability. In addition, the diode's reverse breakdown voltage must exceed the open LED protection voltage.

Input and Output Capacitor Selection

The output capacitor is mainly selected to meet the requirements for the output ripple and loop stability. The output requires a capacitor in the range of 2.2 μ F to 10 μ F.

BLOCK DIAGRAM

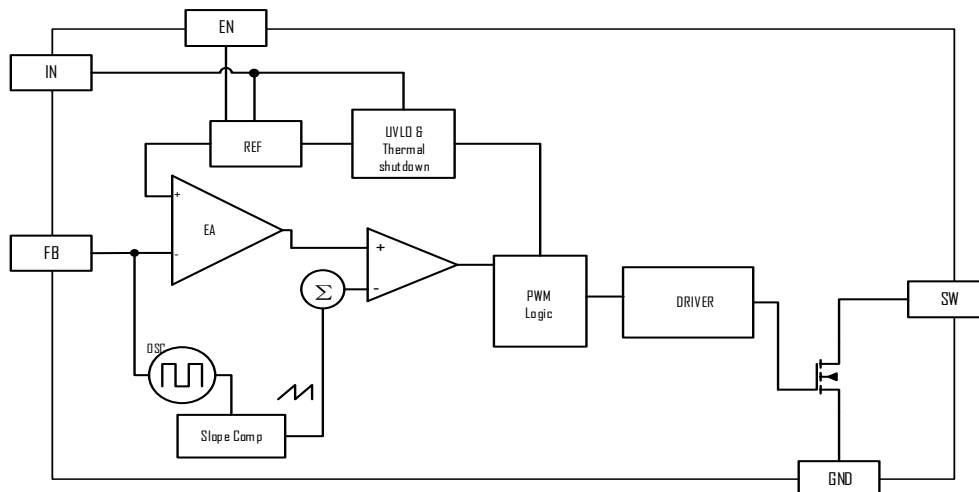

PACKAGE OUTLINE

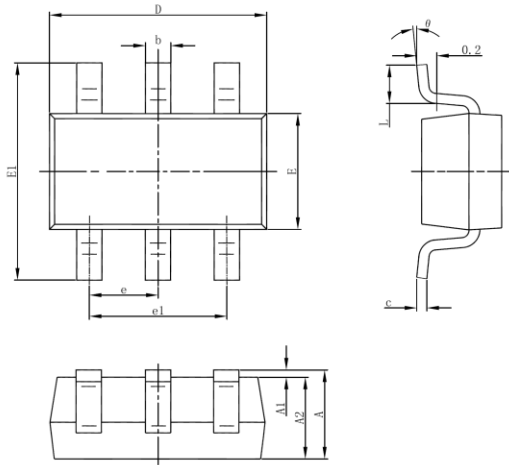

Symbol	Dimensions In Millimeters		Dimensions In Inches	
	Min	Max	Min	Max
A	1.050	1.250	0.041	0.049
A1	0.000	0.100	0.000	0.004
A2	1.050	1.150	0.041	0.045
b	0.300	0.500	0.012	0.020
c	0.100	0.200	0.004	0.008
D	2.820	3.020	0.111	0.119
E	1.500	1.700	0.059	0.067
E1	2.650	2.950	0.104	0.116
e	0.950(BSC)		0.037(BSC)	
e1	1.800	2.000	0.071	0.079
L	0.300	0.600	0.012	0.024
θ	0°	8°	0°	8°