

General Description

The iML8683 is a Three Terminal Current Controller (TTCC) for regulating the current flowing through an LED string.

The application of the iML8683 is configured in parallel with an LED string. The iML8683 can work as voltage controlled current source, current regulator, or cut-off. It is suitable for the applications adopting periodical AC voltage source.

The PCB layout is also very flexible to meet various shape requirements. It is especially suitable for replacing incandescent light bulb and linear type fluorescent lamp.

Features

- **System**
 - All solid state components.
 - No electrolytic capacitor needed.
 - Compact size.
 - High PF and low THD performance.
 - High efficiency achieved.
 - Flexible PCB layout style.
 - Wide range of LED forward voltage selection.
- **Chip**
 - 88V input sustaining voltage.
 - <3V dropout voltage for up to 150mA regulating current.
 - Chip on board process available.

Typical Application Circuit

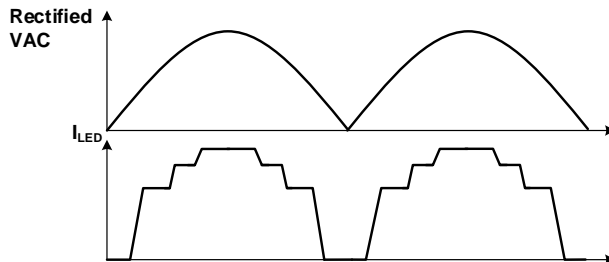
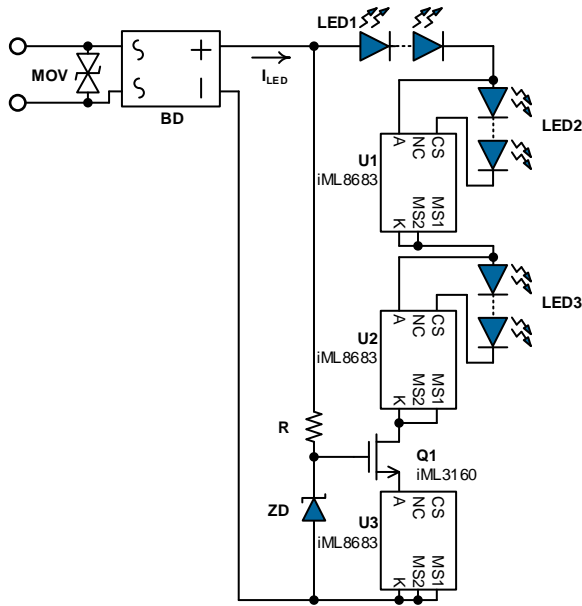

Applications

- AC LED lighting engine.
- LED light bulb.
- LED light tube.

Pin Diagram (Top View)

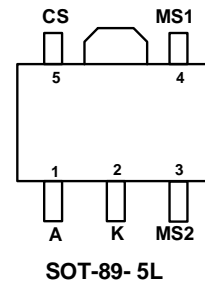
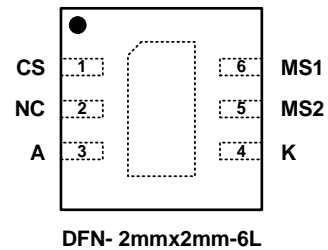

**Ordering Information**

Package Type: DFN– 2mm x 2mm – 6L (Halogen Free)

Part Number	Tape and Reel	1 st Line Marking	Regulating Current (mA) (Mode 0, MS1 and MS2 connected to pin K)
iML8683NL-C1	iML8683NL-C1-TR	83C1	40
iML8683NL-C2	iML8683NL-C2-TR	83C2	66
iML8683NL-C3	iML8683NL-C3-TR	83C3	52
iML8683NL-D1	iML8683NL-D1-TR	83D1	80
iML8683NL-D2	iML8683NL-D2-TR	83D2	130
iML8683NL-D3	iML8683NL-D3-TR	83D3	104
iML8683NL-ADJ	iML8683NL-ADJ-TR	83AD	Determined by external resistor only

Package Type: SOT–89 – 5L (Halogen Free)

Part Number	Tape and Reel	1 st Line Marking	Regulating Current (mA) (Mode 0, MS1 and MS2 connected to pin K)
iML8683BP-C1	iML8683BP-C1-TR	i8683C1	40
iML8683BP-C2	iML8683BP-C2-TR	i8683C2	66
iML8683BP-C3	iML8683BP-C3-TR	i8683C3	52
iML8683BP-D1	iML8683BP-D1-TR	i8683D1	80
iML8683BP-D2	iML8683BP-D2-TR	i8683D2	130
iML8683BP-D3	iML8683BP-D3-TR	i8683D3	104
iML8683BP-ADJ	iML8683BP-ADJ-TR	i8683AD	Determined by external resistor only

Dice

Part Number	Regulating Current (mA) (Mode 0, MS1 and MS2 connected to pin K)
iML8683BZ-C1	40
iML8683BZ-C2	66
iML8683BZ-C3	52
iML8683BZ-D1	80
iML8683BZ-D2	130
iML8683BZ-D3	104
iML8683BZ-ADJ	Determined by external resistor only

Block Diagram

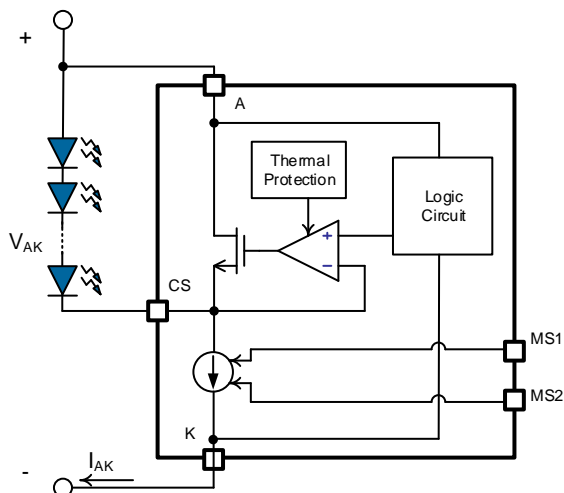

I-V Curve

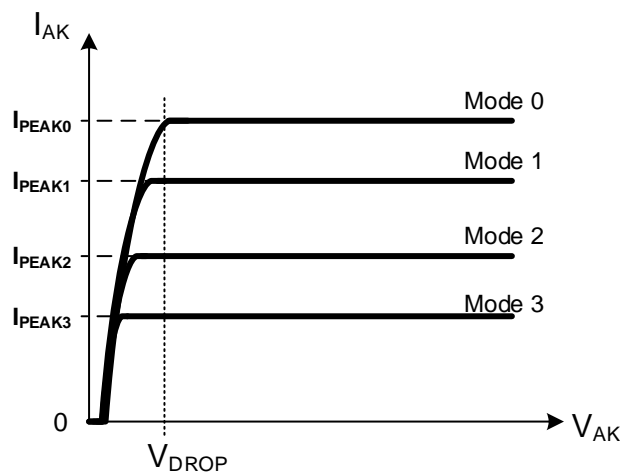

Pin Descriptions

Pin Name	Pin Number		Pin Function
	DFN	SOT-89	
CS	1	5	Current sense pin. Connected to negative end of LED string.
A	3	1	Regulating current input pin. Connected to positive end of LED string.
K	4	2	Regulating current output pin.
MS2	5	3	Mode selection pin 2. Floating or connecting to pin K only.
MS1	6	4	Mode selection pin 1. Floating or connecting to pin K only.
NC	2	-	No Connection
Exposed Thermal Pad			Exposed thermal pad of the chip. Use this pin to enhance the power dissipation ability. The thermal conductivity will be improved if a copper foil on PCB is soldered with the thermal pad. It is recommended to connect the thermal pad to pin K.

Absolute Maximum Ratings

Caution: Values beyond absolute ratings can cause the device to be prematurely damaged. Absolute maximum ratings are stress ratings only and functional device operation is not guaranteed.

Sustaining Voltage	A to K	-0.3V ~ 88V
	CS, MS1, MS2 to K	-0.3V ~ 1V
Regulating Current	150mA	
Maximum Operating Junction Temperature, T_J	165°C	
Operating Temperature, T_{opr}	-40°C to 110°C	
Storage Temperature Range	-55°C to 150°C	
Lead Temperature (Soldering, 10 seconds)	260°C	

Note:

- 1). All voltages are with respect to Ground. Currents are positive into, negative out of the specified terminal.
- 2). All parameters having Min/Max specifications are guaranteed. Typical values are for reference purpose only.
- 3). Unless otherwise noted, all tests are pulsed tests at the specified temperature, therefore: $T_J = T_C = T_A$.

Recommended Operating Conditions

Parameter	Symbol	Min	Typ	Max	Unit
Regulating Current (with Adequate Heat Sinking) ^{*Note}	I_{AK}			130	mA
Input Voltage ^{*Note}	V_{AK}	3		80	V
Maximum Junction Temperature	T_J			150	°C
Operating Free-Air Temperature Range	T_A	-30		100	°C

Note: Due to thermal dissipation consideration, the maximum LED Vf in parallel should decrease with the regulating current.



Electrical Characteristics

Unless otherwise noted, typical values are @ $T_A = 25^\circ\text{C}$.

Parameter	Symbol	Test Conditions	Min	Typ	Max	Unit	
Peak Regulating Current <small>*Note 1,2,3</small>	I_{PEAK0}	$V_{AK}=5V$, Mode 0 (MS1/ MS2 connected to K)	Option C1	38.4	40	41.6	mA
			Option C2	63.4	66	68.6	
			Option C3	49.9	52	54.1	
			Option D1	76.8	80	83.2	
			Option D2	124.8	130	135.2	
			Option D3	99.8	104	108.2	
Current Ratio of Mode Selection <small>*Note 2</small>	I_{PEAK0}/I_{PEAK0}	Option C1/C2/C3/D1/D2/D3, Mode 0, $V_{AK}=5V$ (MS1/ MS2 connected to K)		100		%	
	I_{PEAK1}/I_{PEAK0}	Option C1/C2/C3/D1/D2/D3, Mode 1, $V_{AK}=5V$ (MS1 open, MS2 connected to K)	75	80	85		
	I_{PEAK2}/I_{PEAK0}	Option C1/C2/C3/D1/D2/D3, Mode 2, $V_{AK}=5V$ (MS2 open, MS1 connected to K)	50	55	60		
	I_{PEAK3}/I_{PEAK0}	Option C1/C2/C3/D1/D2/D3, Mode 3, $V_{AK}=5V$ (MS1/ MS2 open)	32	35	38		
Regulating Current Line Regulation <small>*Note 4</small>	$\Delta I_{LR}/I_{PEAKx}$ ($x=0-3$)	Option C1/C2/C3/D1/D2/D3, Mode 1-3, $V_{AK}=5V$ and 40V		± 1	± 2	%	
		Option C1/C2/C3/D1/D2/D3, Mode 0, $V_{AK}=5V$ and 40V	-4	-8	-15		
CS Pin Voltage	V_{CS}	Option ADJ, Mode 0, $V_{AK}=5V$, with 1k Ω external resistor between CS and K	0.26	0.27	0.28	V	
CS Pin Voltage Line Regulation <small>*Note 5</small>	$\Delta V_{LR}/V_{CS}$	Option ADJ, Mode 1-3, $V_{AK}=5V$ and 40V with 1k Ω external resistor between CS and K		± 1	± 2	%	
		Option ADJ, Mode 0, $V_{AK}=5V$ and 40V with 1k Ω external resistor between CS and K	-4	-8	-15	%	
Dropout Voltage <small>*Note 6</small>	V_{DROP}	Mode 0 (MS1/ MS2 connected to K)		2.8	3.8	V	
Thermal Protection Trip Temperature <small>*Note 7,8</small>	T_{TP}	When T_J is higher than T_{TP} , the peak regulating current decreases to I_{TP} linearly.	110	125		$^\circ\text{C}$	
Thermal Protection Mode Regulating Current	I_{TP}/I_{PEAKx} ($x=0-3$)	$T_J = 170^\circ\text{C}$		50		%	

Note 1: Need to have negative temperature coefficient.

Note 2: For option ADJ, the regulating current is determined by external resistor, R_{EXT} , connected between pin CS and pin K. The mode selection function will not change the current ratio of option E1. To activate the line regulation function, U3 (connected with LED in series) should be set in Mode 0 (MS1 and MS2 connected to pin K). The regulating current will be:

$$I_{PEAK} = 0.27/R_{EXT}$$

And the maximum regulating current of second step (ex. U1 in Mode 1) should not exceed 80% of U3, otherwise the circuit operation might become abnormal when OTP function is activated.

Note 3: Customer can add an external resistor R_{EXT} between pin CS and pin K of U3 (Mode 0, serial connected to LED string) to increase the regulating current of option C1, C2, C3, D1, D2 and D3, as shown below. For U1~U2 (Mode 1 ~ Mode 3, parallel connected to LED string), adding an external resistor R_{EXT} between pin CS and pin K may cause abnormal operation and chip damage.

For option C1/ C2/ C3, the regulating current variation $\Delta I_{PEAK}/I_{PEAK} = 6.25/R_{EXT}$.

For option D1/ D2/ D3, the regulating current variation $\Delta I_{PEAK}/I_{PEAK} = 3.13/R_{EXT}$.

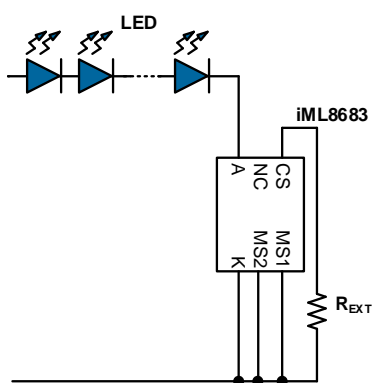

	U3 (Mode 0) regulating current	
	Without external resistance	With 100Ω external resistance
Option C1	40	42.5
Option C2	66	70.1
Option C3	52	55.3
Option D1	80	82.5
Option D2	132	136.1
Option D3	104	107.3

Note 4: The Regulating Current Line Regulation is defined as:

$$\text{For Mode 1~3: } \Delta I_{LR}/I_{PEAKx} = \frac{I_{AK}(V_{AK=40V}) - I_{AK}(V_{AK=5V})}{I_{AK}(V_{AK=5V})}, \quad x=1\sim3$$

$$\text{For Mode 0: } \Delta I_{LR}/I_{PEAK0} = \frac{I_{AK}(V_{AK=40V}) - I_{AK}(V_{AK=5V})}{I_{AK}(V_{AK=5V})}$$

Note 5: The CS Pin Voltage Line Regulation is defined as:

$$\text{For Mode 1~3: } \Delta V_{LR}/V_{CS} = \frac{V_{CS}(V_{AK=40V}) - V_{CS}(V_{AK=5V})}{V_{CS}(V_{AK=5V})}$$

$$\text{For Mode 0: } \Delta V_{LR}/V_{CS} = \frac{V_{CS}(V_{AK=40V}) - V_{CS}(V_{AK=5V})}{V_{CS}(V_{AK=5V})}$$

Note 6: Dropout voltage = $V_{AK} @ 90\% \times (I_{PEAK0} @ V_{AK=5V})$

Note 7: Guarantee by design, not by production test.

Note 8: When $T_j > T_{TP}$, the peak regulating current decreases linearly to around 50% at 170°C.

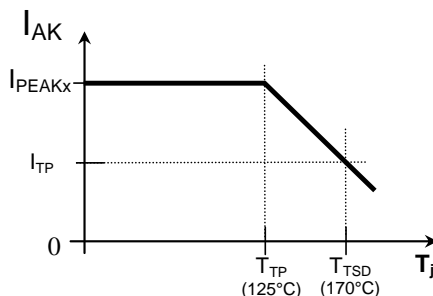



Application Circuit

220V/ 10W LED light engine (3 steps, PF=0.98, THD=16%)

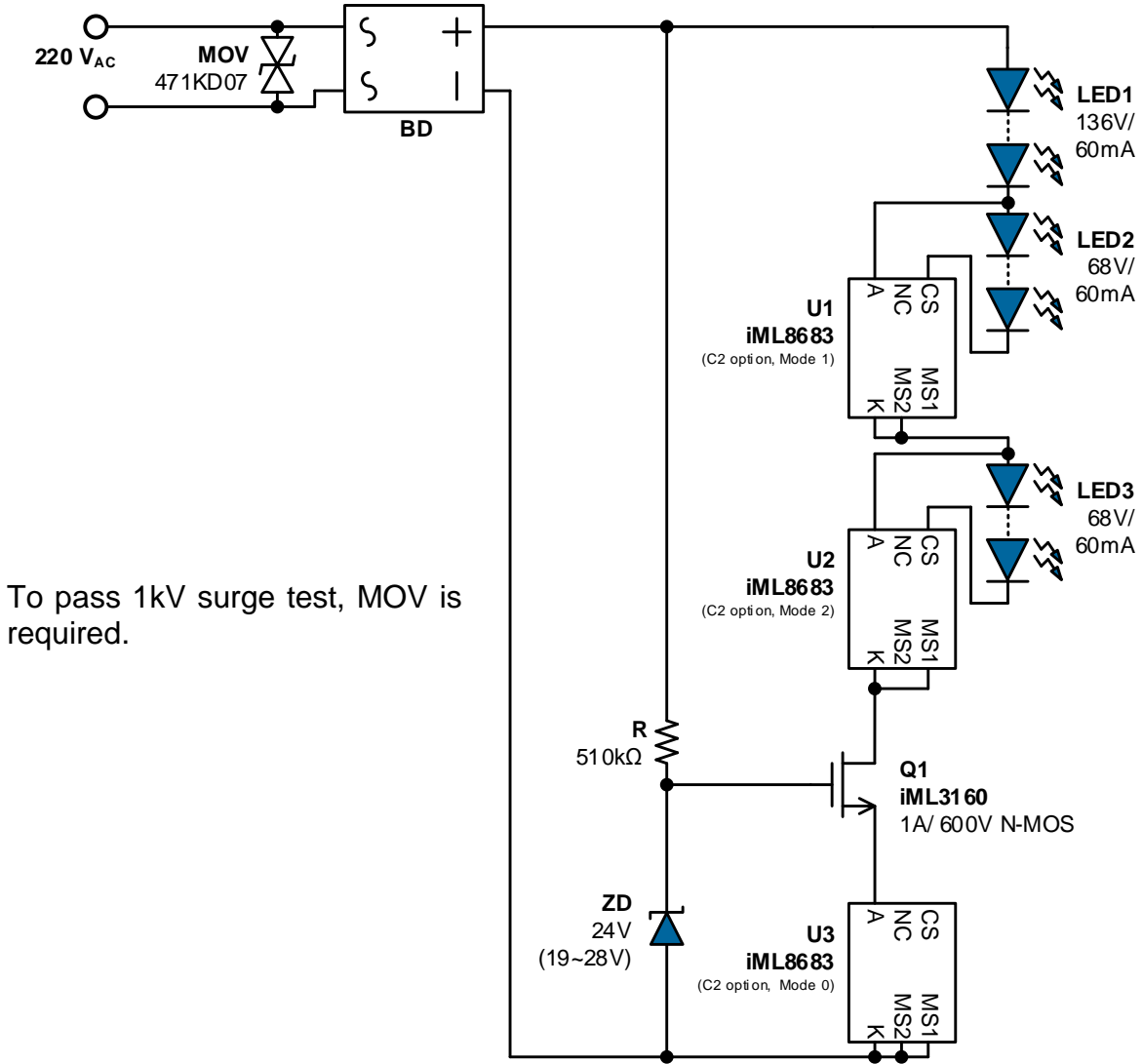

To pass 1kV surge test, MOV is required.



INTEGRATED MEMORY LOGIC

Specification iML8683

Proprietary Technology Three Terminal Current Controller

110V/ 10W LED light engine (3 steps, PF=0.98, THD=16%)

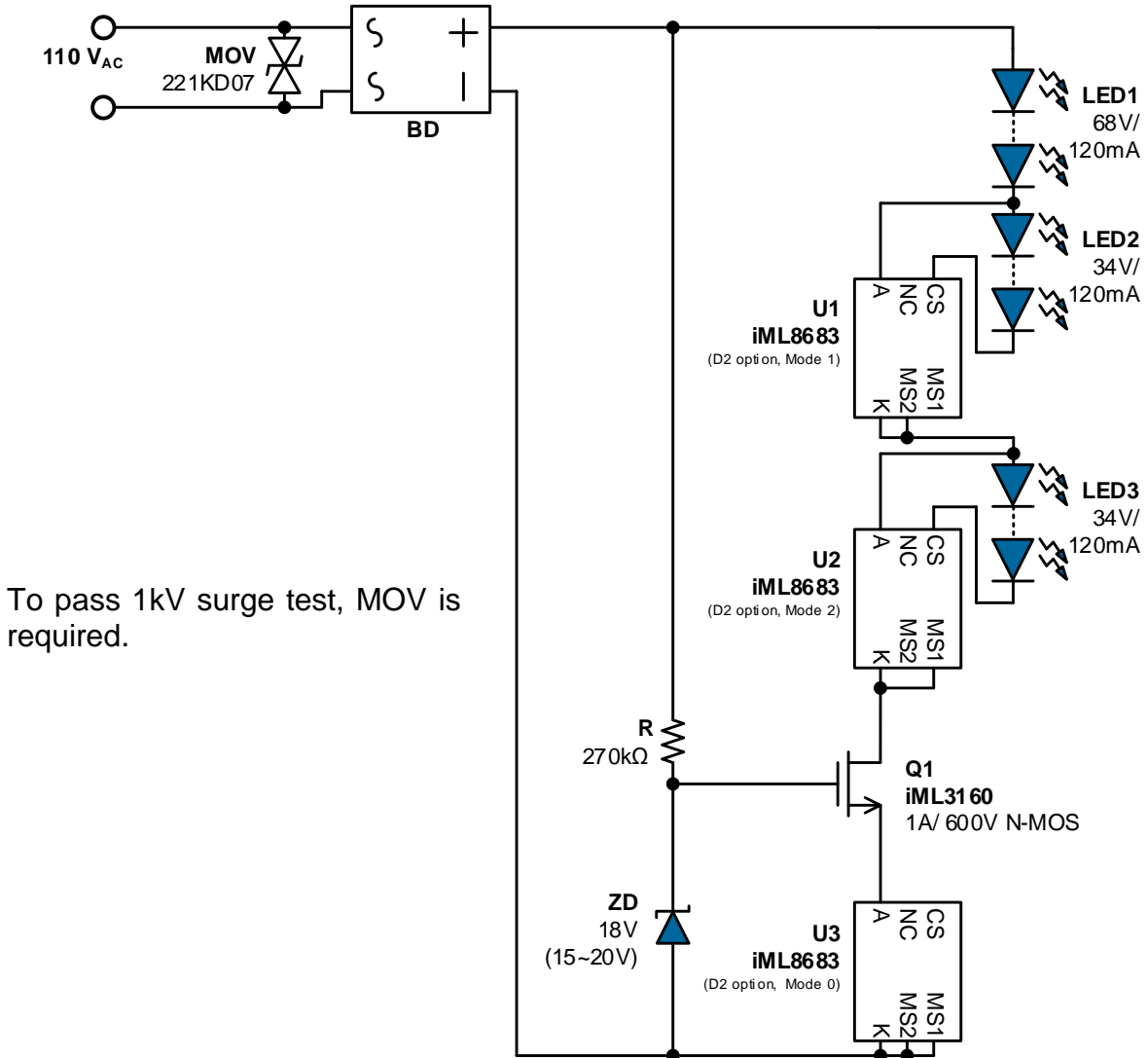

To pass 1kV surge test, MOV is required.



Package Information

DFN- 2mmx2mm- 6L

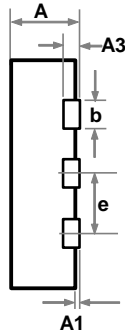
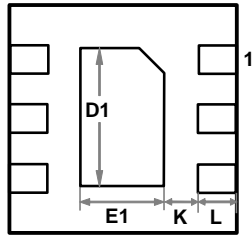
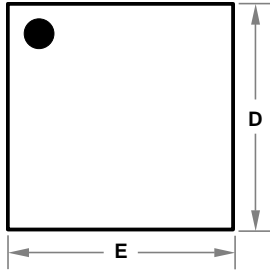

SYMBOLS	MIN.	NOM.	MAX.
A	0.70	0.75	0.80
A1	0.00	0.02	0.05
A3	-	0.20	-
b	0.20	0.30	0.35
D	-	2.00	-
D1	-	1.40	-
E	-	2.00	-
E1	-	0.70	-
e	-	0.65	-
K	0.20	-	-
L	-	0.30	-

UNIT: MILLIMETERS

Footprint Suggestion

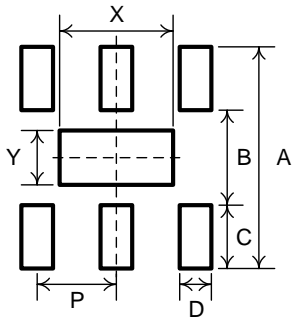

SYMBOLS	Footprint Dimension
A	2.80
B	1.20
C	0.80
D	0.35
P	0.65
X	1.40
Y	0.70

θ_{JA}	103 °C / W
---------------	------------



INTEGRATED MEMORY LOGIC

Specification iML8683

Proprietary Technology Three Terminal Current Controller

SOT-89-5L

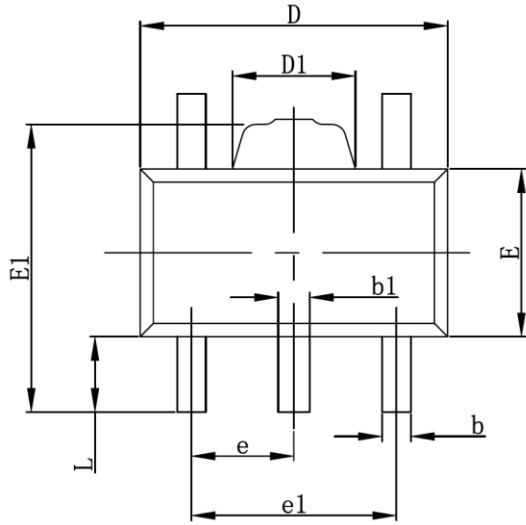

SYMBOLS	MIN.	MAX.
A	1.40	1.60
b	0.32	0.52
b1	0.36	0.56
c	0.35	0.44
D	4.40	4.60
D1	1.40	1.80
E	2.30	2.60
E1	3.94	4.25
e	1.50 TYP	
e1	2.90	3.10
L	0.90	1.10

UNIT: MILLIMETERS

Footprint Suggestion

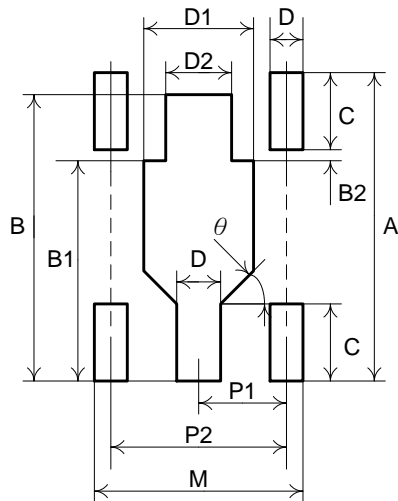

SYMBOLS	Footprint Dimension
A	5.20
B	4.80
B1	3.65
B2	0.20
C	1.35
D	0.70
D1	1.90
D2	1.30
M	3.70
P1	1.50
P2	3.00
θ	45°

UNIT: MILLIMETERS

θ_{JA}	127.5 °C / W
---------------	--------------