

功能描述

HT1608 是一款低功耗并具有高性能的原边 PFM 转换器，主要针对充电器而设计，省去外部光耦和 TL431，同时也省去外部 FB 反馈电压检测电阻，最大程度的节约了系统成本。HT1608 除了为用户提供高性价比的 AC/DC 电源系统应用以外，而且 IC 内部高度集成了欠压保护，过温保护，开短路保护等功能，使得 IC 的工作寿命大大延长，HT1608 外部工作电路简单，可以根据客户应用要求选择不同封装。

特点

- ◆ CV 控制模式
- ◆ 原边控制调节
- ◆ 省去外部光耦和 TL431,省去外部 FB 反馈检测电阻
- ◆ 内部集成 NPN 三极管
- ◆ 限流保护
- ◆ 过温保护
- ◆ 过压保护
- ◆ 开短路保护
- ◆ 最大输出功率可达 5W
- ◆ 采用 TO-126 封装形式

应用范围

- ◆ 手机等数码产品充电器 / 适配器
- ◆ 万能充电器
- ◆ 标准和辅助供电模块
- ◆ 线性电源和替代 RCC 开关电源的最佳选择

管脚说明

管脚图	序号	名称	功能说明
 1 2 3 TO-126	1	VCC	电源正极
	2	C	三极管集电极
	3	GND	电源负极

极限参数

OUT to GND.....	-0.3V to +9V
VCC to GND.....	-0.3V to +9V
Operating Temperature Range	-40°C to +125°C
Junction Temperature Range.....	-40°C to +150°C
Storage Temperature Range.....	-60°C to +150°C

Stresses exceeding maximum ratings may damage the device. Maximum ratings are stress ratings only. Functional operation above the recommended operating conditions is not implied. Extended exposure to stresses above the recommended operating conditions may affect device reliability.

电气参数

VDD=5V , Vout=5V , Ta=25°C, unless otherwise specified

Parameters	Symbol	Test Condition	Min	Typ	Max	Unit
开启电压	UVLO_ON	VDD rising from 0	5	6	7	V
关闭电压	UVLO_OFF	VDD falling after turn on	2.5	3	3.5	V
OC 集电极承受电压	Vcbo	--	--	--	650	V
工作电流	Ic	VDD=5V after turn on	--	--	500	mA
启动电流	Ibase	VDD rising before turn on	35	43	55	uA
前沿消隐时间	Toff_max	--	574	887	1290	ns
结温	OTP	--	--	150	--	°C

电路原理图

全波整流应用方案



图 1

半波整流应用方案

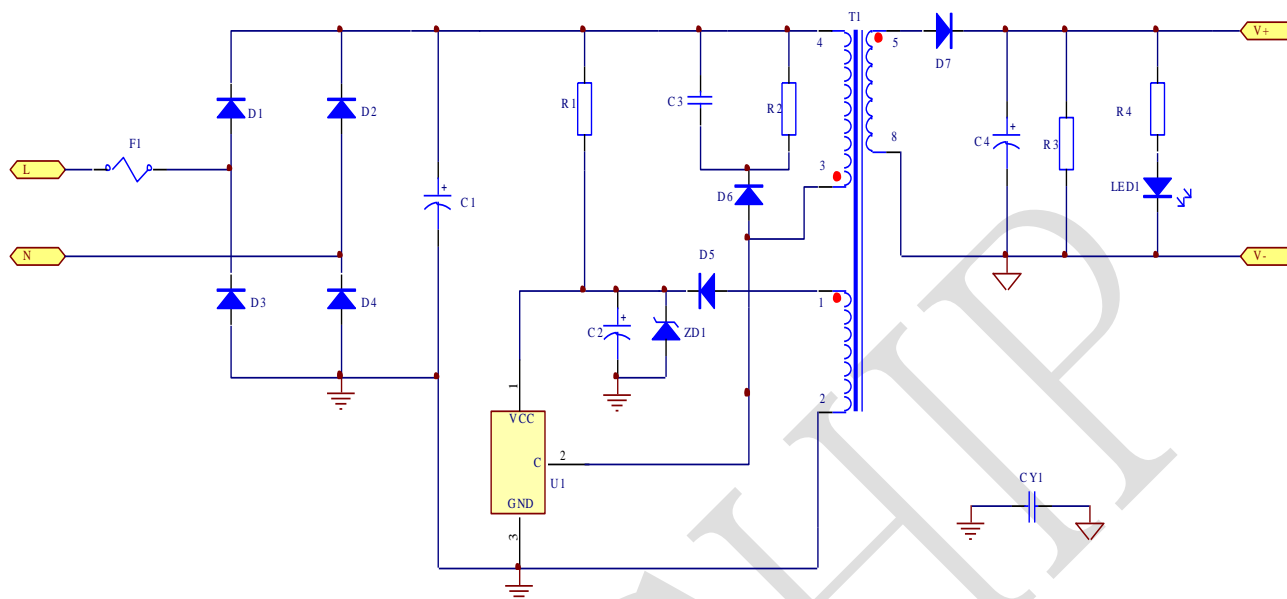

图 2

注：CY1 安规电容按客户要求来追加。

封装尺寸图

PACKAGE OUTLINE DIMENSIONS

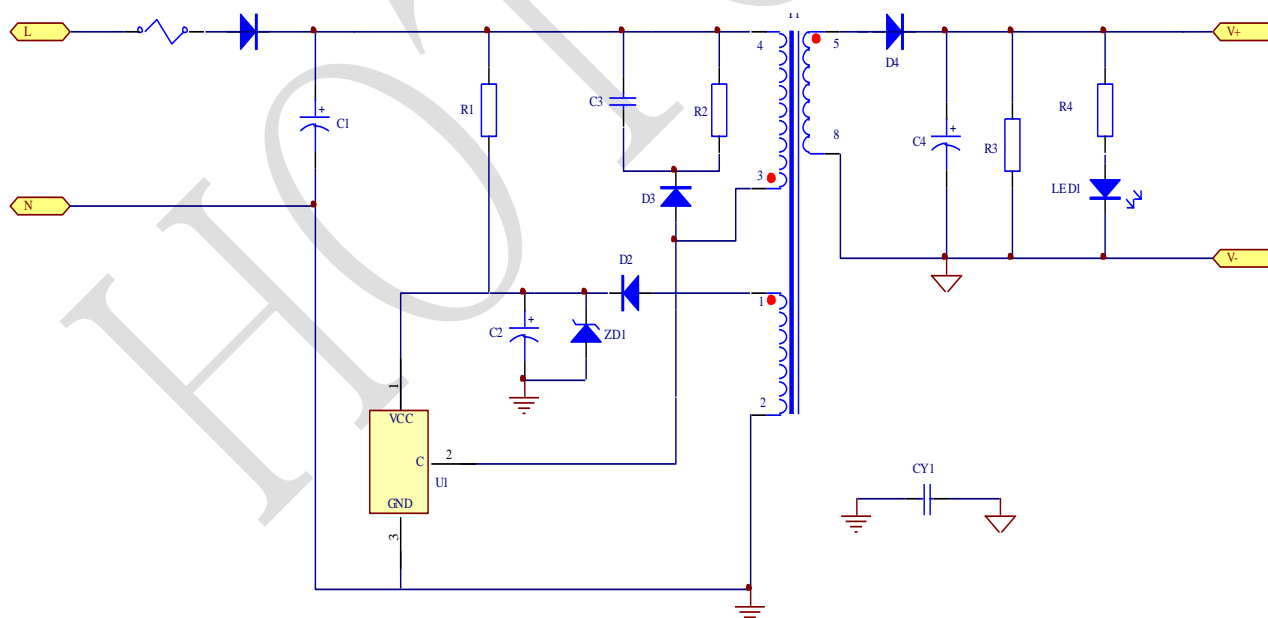
TO-126:

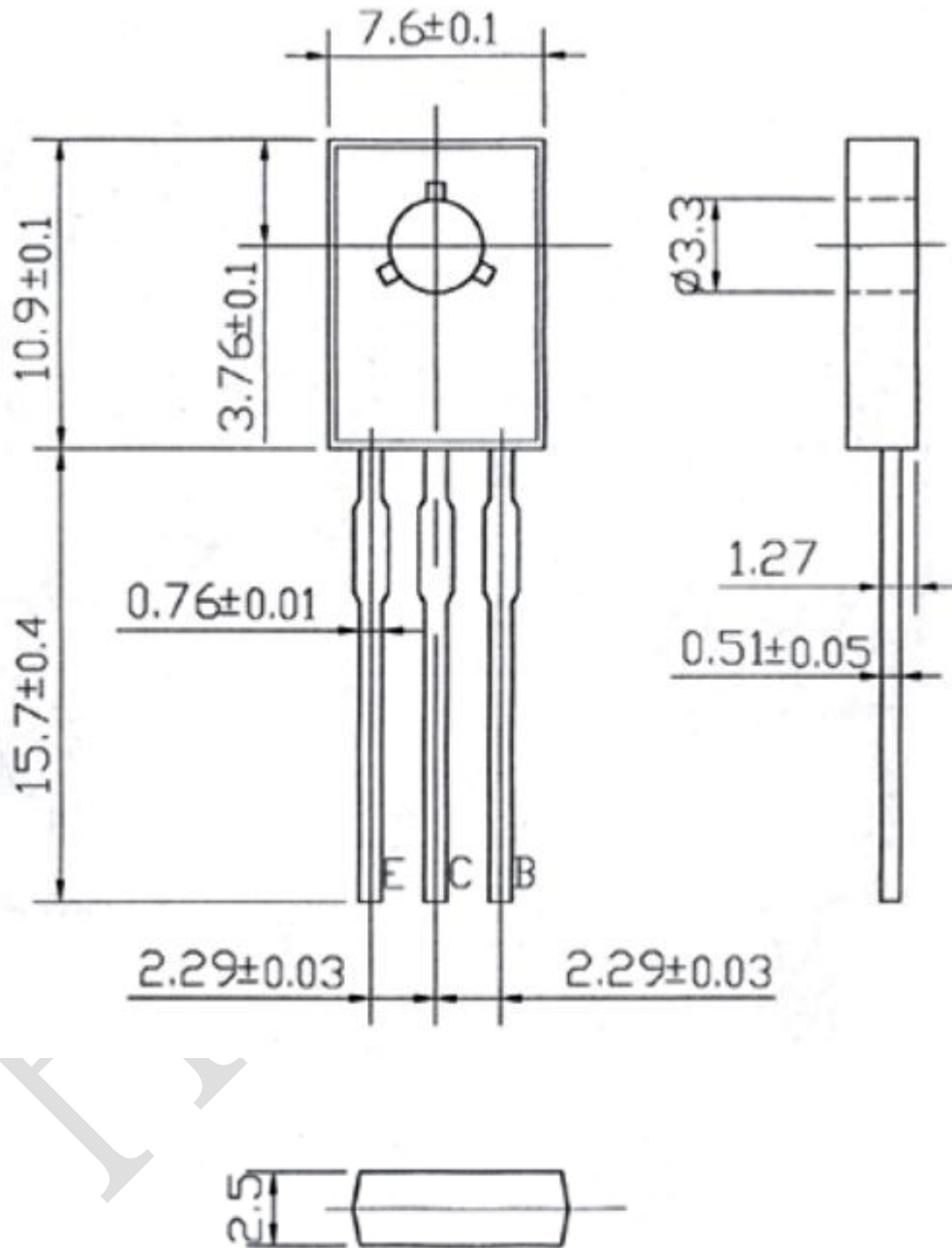

Copyright © 2008 by HOTCHIP TECHNOLOGY CO., LTD.

The information appearing in this Data Sheet is believed to be accurate at the time of publication. However, HOTCHIP assumes no responsibility arising from the use of the specifications described. The applications mentioned herein are used solely for the purpose of illustration and HOTCHIP makes no warranty or representation that such applications will be suitable without further modification, nor recommends the use of its products for application that may present a risk to human life due to malfunction or otherwise. HOTCHIP's products are not authorized for use as critical components in life support devices or systems. HOTCHIP reserves the right to alter its products without prior notification. For the most up-to-date information, please visit our web site at <http://www.hotchip.com.cn>.

HOTCHIP