

100V 0.5A Switching Current Buck PFM LED Constant Current Driver**XL8005****Features**

- Wide 24V to 100V Input Voltage Range
- 0.2V current sense voltage reference.
- Directly drive 3~8 series 1W LED.
- Excellent line and load regulation.
- High efficiency up to 96%.
- Minimum Drop out >6V.
- Internal optimize power HV-MOSFET.
- Built in thermal shutdown function.
- Built in UVLO function.
- Built in current limiting function.
- Built in LED open & short protection.
- Built in soft-start circuit.
- Available in SOIC-8 package.

Applications

- EBIKE LED Lighting
- LED Lighting & LED LAMP
- General purpose lighting

General Description

The XL8005 is a monolithic high voltage switching regulator with PFM that is specifically designed to operate from a 24V~100V DC supply.

The XL8005 is a high efficiency LED driver switching regulator. The LED string is driven at DC constant current rather than constant voltage, thus providing constant current output and enhanced reliability.



SOIC-8

Figure1. Package Type of XL8005

100V 0.5A Switching Current Buck PFM LED Constant Current Driver

XL8005

Pin Configurations

NC	1	8	CSN
VDD	2	7	CSN
XL8005			
CSP	3	6	VIN
SW	4	5	VIN

Figure2. Pin Configuration of XL8005 (Top View)

Table 1 Pin Description

Pin Number	Pin Name	Description
1	NC	No Connected.
2	VDD	The chip supply voltage.
3	CSP	Current Sense Positive Terminal.
4	SW	Output Switching Pin
5, 6	VIN	Input high voltage Pin. (Operation voltage 24V~ 100V)
7, 8	CSN	Current Sense Negative Terminal.

Function Block

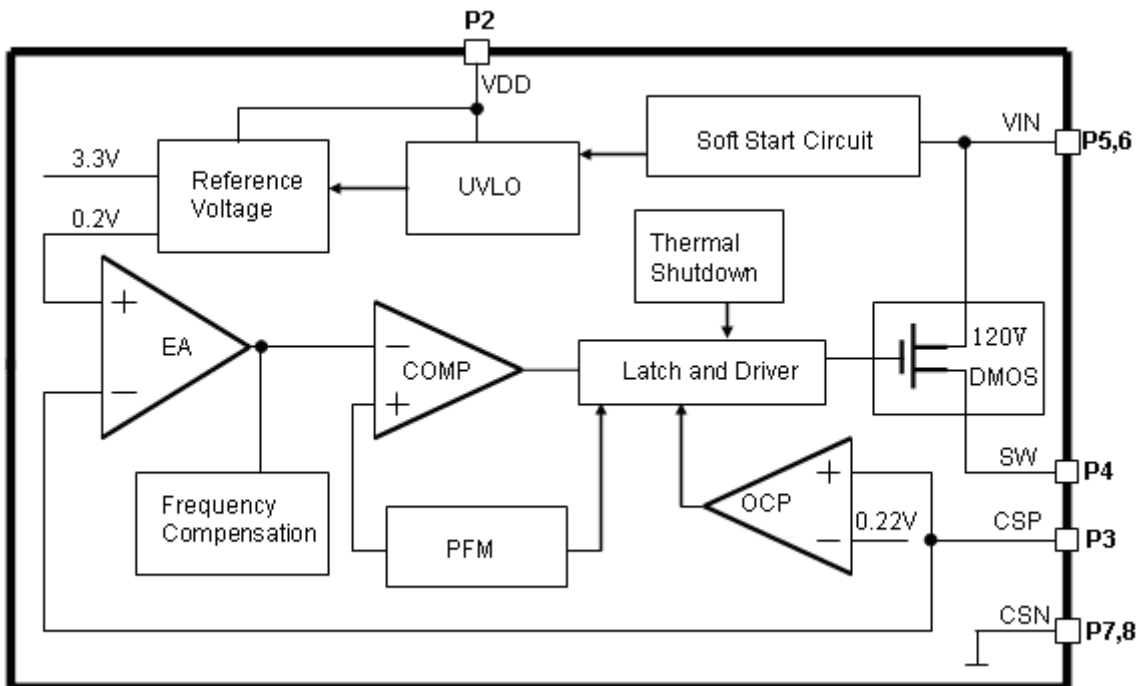
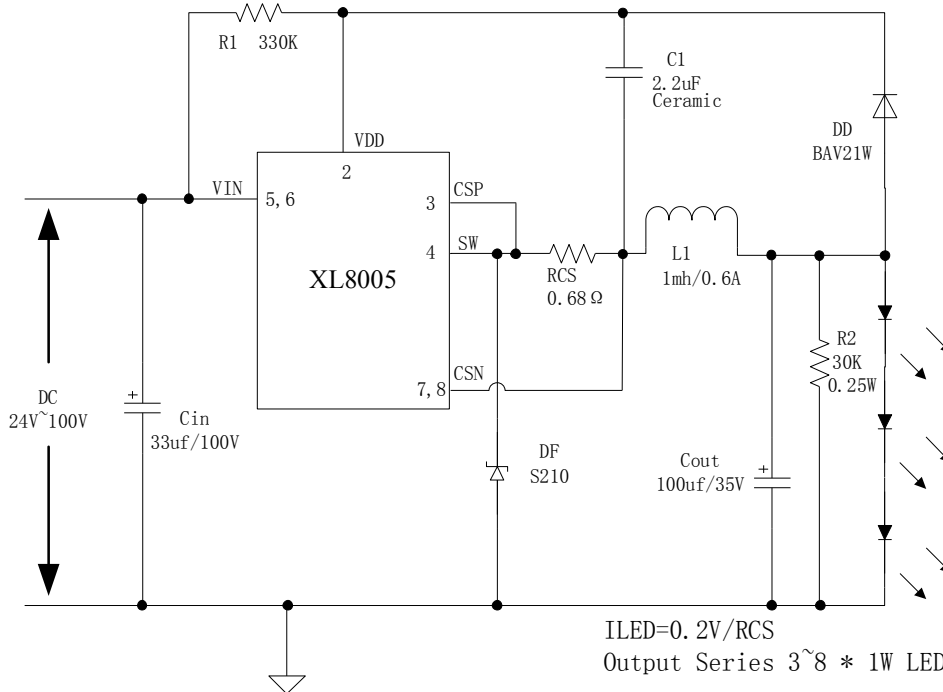

Figure3. Function Block Diagram of XL8005

100V 0.5A Switching Current Buck PFM LED Constant Current Driver

XL8005

Typical application circuit



- [1] Input DC 24V~100V.
- [2] Output Constant Current Drive Series 3~8 * 1W LED.
- [3] Support Output LED Open & Short Protection.

Figure4. XL8005 Typical Application (3W~8W LED lamp)

Ordering Information

Order Information	Marking ID	Package Type	Packing Type
XL8005E1	XL8005E1	SOIC-8	2500 Units on Tape & Reel

XLSEMI Pb-free products, as designated with “E1” suffix in the par number, are RoHS compliant.

Absolute Maximum Ratings (Note1)

Parameter	Symbol	Value	Unit
Input Voltage	V _{in}	-0.3 to 120	V
Power Dissipation	P _D	Internally limited	mW
Thermal Resistance (SOP-8L) (Junction to Ambient, No Heatsink, Free Air)	R _{JA}	100	°C/W
Operating Junction Temperature	T _J	-40 to 125	°C
Storage Temperature	T _{STG}	-65 to 150	°C
Lead Temperature (Soldering, 10 sec)	T _{LEAD}	260	°C
ESD (HBM)		3000	V

100V 0.5A Switching Current Buck PFM LED Constant Current Driver

XL8005

Note1: Stresses greater than those listed under Maximum Ratings may cause permanent damage to the device. This is a stress rating only and functional operation of the device at these or any other conditions above those indicated in the operation is not implied. Exposure to absolute maximum rating conditions for extended periods may affect reliability.

XL8005 Electrical Characteristics

T_a = 25°C; unless otherwise specified. Reference test circuit figure4

Symbol	Parameter	Test Condition	Min.	Typ.	Max.	Unit
VCSP	CSP Voltage	VIN = 24V to 100V, Iled=0.3A, Pout=8W	190	200	210	mV
Efficiency	η	VIN=48V, Iled=0.3A, Pout=8W	-	94.8	-	%
Efficiency	η	VIN=60V, Iled=0.3A, Pout=8W	-	94.0	-	%
Efficiency	η	VIN=72V, Iled=0.3A, Pout=8W	-	92.8	-	%
Efficiency	η	VIN=84V, Iled=0.3A, Pout=8W	-	92.3	-	%

Electrical Characteristics (DC Parameters)

Parameters	Symbol	Test Condition	Min.	Typ.	Max.	Unit
Input operation voltage	VIN		24		100	V
Switching Frequency	Fosc	Figure4 (8*1W) VIN=48V	47.4	59.3	71.1	KHz
Switching Frequency	Fosc	Figure4 (8*1W) VIN=60V	56.2	70.3	84.3	KHz
Switching Frequency	Fosc	Figure4 (8*1W) VIN=72V	61.2	76.5	91.8	KHz
Switching Frequency	Fosc	Figure4 (8*1W) VIN=84V	64.1	80.2	96.2	KHz
DMOS Drain-Source Breakdown Voltage	VBRDS	VGS=0V, IDS=250uA	120			V
DMOS Drain-Source on resistor	RDS(on)	IDS=0.5A, VGS=10V		0.1	0.15	Ohm
Thermal Shutdown	OTP	Tj		165		°C
Thermal Shutdown Window				25		°C

100V 0.5A Switching Current Buck PFM LED Constant Current Driver

XL8005

[1] Typical application circuit (3W ~ 8W)

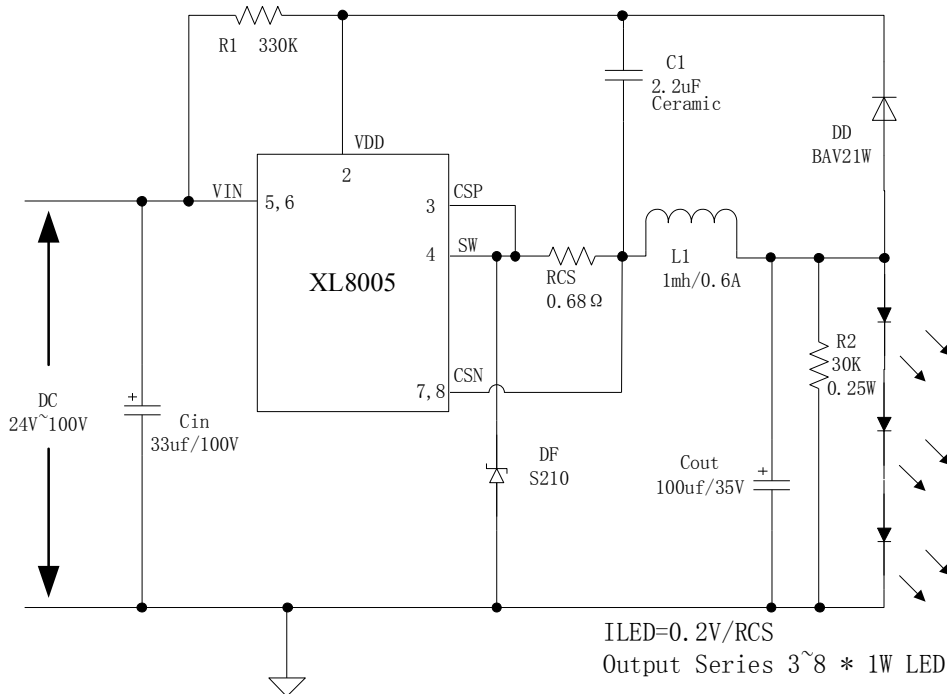

- [1] Input DC 24V~100V.
- [2] Output Constant Current Drive Series 3~8 * 1W LED.
- [3] Support Output LED Open & Short Protection.

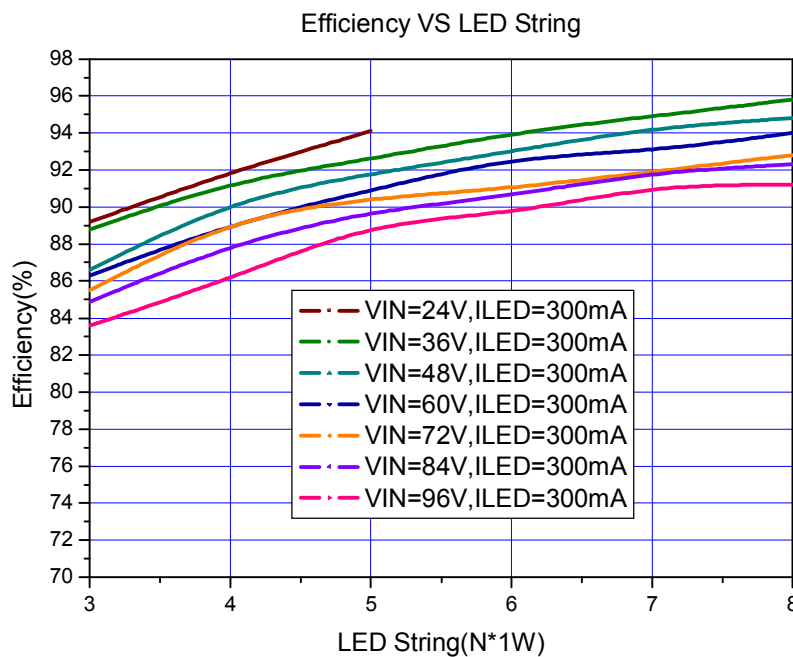
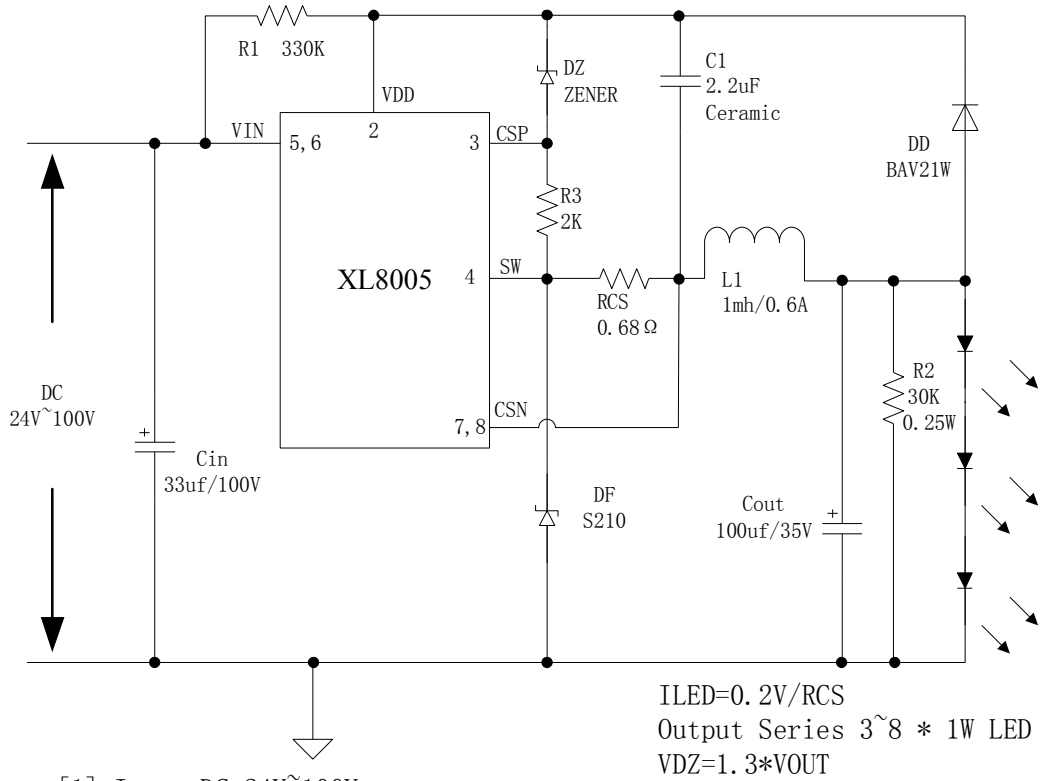

Figure5. XL8005 System Application& efficiency curve

[2] Typical application circuit (Low LED open voltage)



- [1] Input DC 24V~100V.
- [2] Output Constant Current Drive Series 3~8 * 1W LED.
- [3] Support Output LED Open & Short Protection.

Figure6. XL8005 System Application with low LED open voltage

Package Information

SOP8 Package Mechanical Dimensions

SOIC-8

Unit: mm(inch)

