



Current Share Board

“Current sharing” also known as Load Sharing, is the ability to divide the output current evenly across all active power supplies. This greatly reduces stresses on each power supply and allows them to run cooler resulting in higher reliability. Standard “current sharing” techniques typically utilize shunt resistors or Hall Effect devices to measure the current from each power supply. Power shunt resistors continually dissipate power and require cooling especially when dealing with high output currents of >100Amps. Hall Effect devices measure magnetic fields generated by current flowing through a conductor and, although they dissipate no power, they tend to be large and expensive.

First developed by Westcor Engineering for paralleling MegaPAC supplies, the Box-to-Box Current Share Board or CSB allows two or more Vicor power supplies to current share by utilizing the inherent voltage drop produced in the negative output return cable. This eliminates the need for additional shunt resistors or expensive Hall Effect devices and provides a simple 5 wire connection method to achieve a $\pm 1\text{mV}$ accuracy between the Negative Output power rails. This accuracy translates to a 1% current sharing if there is a total of 100mV conduction voltage drop in the negative return path.

Constructed as a current source to drive the Trim pin of a Vicor module, the design uses an accurate comparator circuit to monitor the power returns. In addition, the circuit is unidirectional and can only trim an output voltage up. The benefit is that only the supply that is supporting less current is adjusted up. This action balances the currents to the load by matching the output voltages of the supplies. In the case of one supply failing, the circuit will attempt to trim the failed supply only. This will leave the remaining functional supply alone to provide power to the load at its nominal voltage. Thus the circuit also offers simple redundancy. In addition, because CSB functions as a current source,

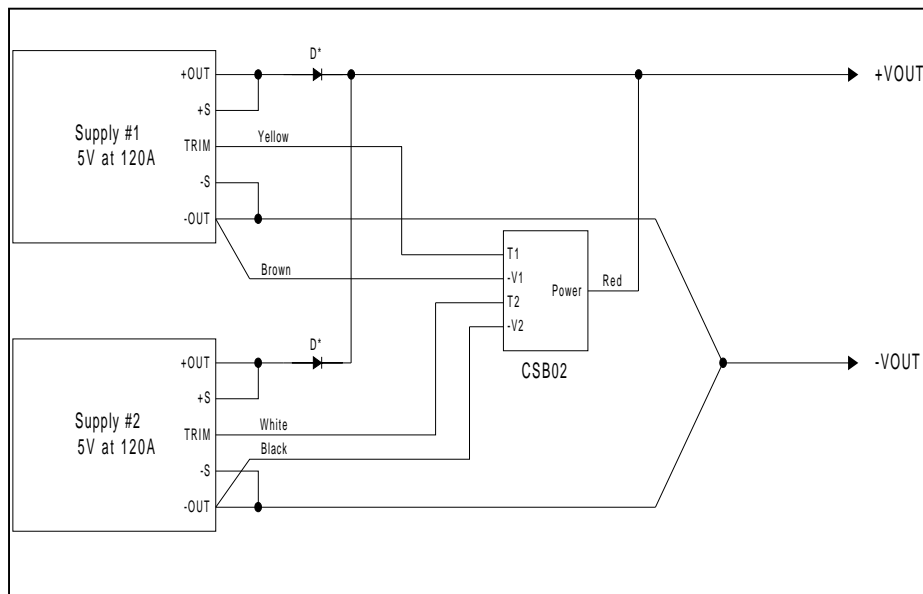

Figure 1. CSB Interconnect Example

the Trim outputs (T1 and T2) of the CSB can be placed in parallel to create a summing node. This allows current sharing between more than two supplies by paralleling the T2 output of one CSB circuit with the T1 output of the next CSB.

Please note: The CSB is not intended for use in Hotswap Applications.

Requirements:

- 1) For proper operation, the power supplies being paralleled should be enabled at the same time.
- 2) –Out conductors must be of equal length and wire gauge. Separate –Out conductors must be used from each supply to the load, or the use of a “Y” connection to a common point must be used as shown in figure 1. Each leg of the “Y” must have a minimum of a few millivolts of drop in order for proper operation. 50mV to 100mV of drop will provide from 5% to 1% accuracy.
- 3) –V1 and –V2 for all Box-to-Box circuits must be connected directly at the negative output power studs or terminals to achieve accurate current sharing.
- 4) D* can be added if redundancy is needed. If redundancy is not required, D* can be replaced with direct wire connections.
- 5) When using D*, the Power input should be connected on the cathode side of the paralleling diodes as shown above.
- 6) Terminate Sense Leads either locally or remotely as shown in figure 1.
- 7) For paralleling more than 2 supplies consult factory for assistance.



Box-to-Box Current Sharing
(page 2)

J1 Pinout

Pin	Description
1	Power
2	T1
3	-V1
4	T2
5	-V2
6	No Connection

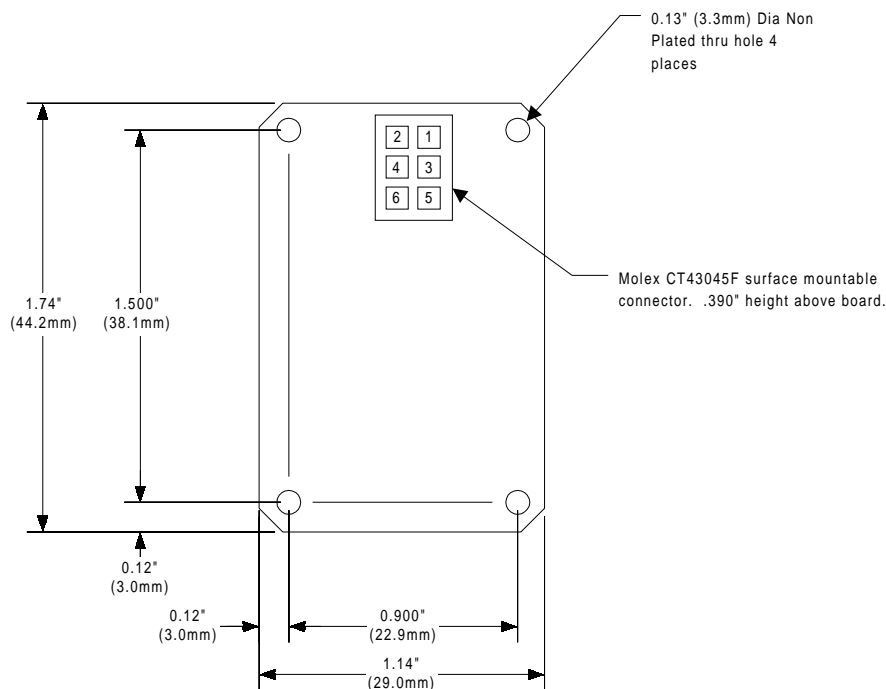

Figure 2. Mechanical Drawing



Figure 3. Cable Drawing

Specifications:

- 1) Power: 2-50Vdc at 5mA maximum
- 2) Accuracy: +/-1mV between -Vout connections
- 3) Output current when not trimming up: +/-1uA (VI-200/J00), +/-5uA (2nd Generation)
- 4) Use 4 non-plated through holes with standoffs for mounting
- 5) CSB01 MUST be used for current sharing VI-200/J00 series converters.
- 6) CSB02 MUST be used for current sharing 2nd Generation converters.

Please note, the CSB is NOT intended for Hotswap Applications

Contact your regional Applications Engineer at 1-800-927-9474 for additional information.